

DOUBLE-ACTING AIR-OPERATED PISTON PUMPS

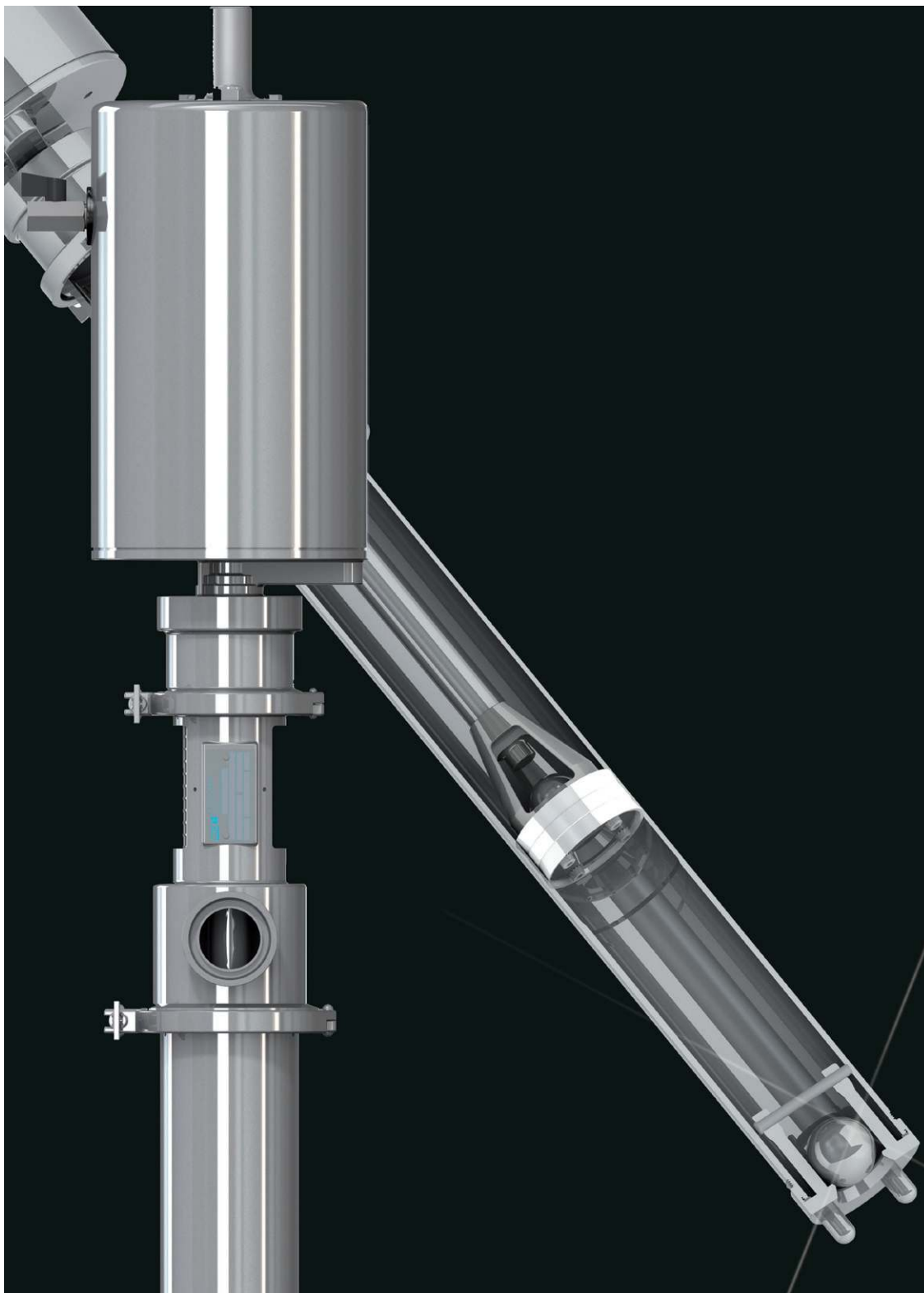

AIR-OPERATED
PISTON
PUMPS

CSFR
INOX

C.S.F. INOX SPA

PREFACE AND WARNING

This publication does not constitute a contract proposal or an offer to the public or product advertisement.

This publication is reserved to the internal operators of C.S.F. INOX.

Any kind of product sale and marketing can occur only according to the general terms of contract and special conditions listed by C.S.F. INOX as per contract forms.

All the instructions, data and representations (in whatever way executed) listed in this publication are indicative and do not binding.

C.S.F. does not stand surety or undertake any obligation for the utilisation of this document and for the information contained. In particular, it does not guarantee against omissions or errors of the data and drawings here indicated.

Notice that the technical specifications, information and representations in this document are merely indicative and approximate.

C.S.F. INOX reserves the right at any moment and without notice to modify the data, drawings and information indicated in this document.

C.S.F. INOX recommends anyone to verify with the C.S.F. INOX operators contractual conditions and the product characteristics as per the official documents attached to all products in the C.S.F. INOX range.

All the general and non-binding technical specifications and representations may not correspond to the real conditions of the products and to their operating modes for each different application.

C.S.F. INOX guarantees its own products according to the general guarantee conditions in compliance with the required modes of utilisations as per separate documents, regardless of what is indicated in this document, if the assembly and operating methods of the products are observed.

Only the instructions indicated in the contract documents, if duly undersigned by authorised C.S.F. INOX personnel, are binding for C.S.F. INOX.

We remind our technical and business collaborators to show the customer our range of products indicating the technical specifications of each type, with the conditions of utilisation and the actual utilisation methods.

Please consider this warning carefully because C.S.F. INOX shall not be liable for any utilisation of this document, of the data and representations here indicated.

The C.S.F. **AIR-OPERATED PISTON PUMPS** are available in various executions, both with regard to constructional features, materials and the various applications for which they are to be used. They have been designed to meet the widest variety of requirements of pumping products with extremely high viscosities to transfer, feed, convey, spray and for whichever equipment requiring an adjustable delivery rate.

Thanks to the compressed air motor they are also suitable in environments with potentially explosive atmospheres and in compliance with ATEX directives. Heads vary from 0 to 150 bar and deliveries from 1 to 80 l/min. They are made up of a compressed air motor, which in its alternated movement provides the pumping shaft with the power necessary to move the product from the in-take to the outlet. Sealing parts and pumping elements are available in a wide range of materials and shapes all designed and tested for the various applications.



FOOD INDUSTRY:

Creams, puddings, sweet stuffing, ice-creams, eggs, egg flip, honey, yoghurt, mustard, tomato sauce, dairy cream, melted cheese, jams, ragout, vegetable soup, "polenta", mayonnaise, melted chocolate, oils.

DRINKS INDUSTRY:

Syrups, juices, wines, spirits, glucose, concentrates, essences, flavours.

PHARMACEUTICAL AND COSMETIC INDUSTRIES:

Extracts, essences, solutions, soaps, shampoo, bubble bath, tooth paste, shaving creams, beauty creams.

CHEMICAL, TEXTILE, PRINTING INDUSTRIES:

Acids, bases, solution or dispersed salts, solvents, liquefied gases, oils paints, enamels, filler, plasters, resins, inks, adhesives, glues.





PERFORMANCES			
PUMPS	Pressure ratio	Recomm. max. cycles per minute	Max. flow rate l/min for viscosity of 1000 cP
PA 20 A- 45	25 : 1	150	1
* PA 30 A- 45	5 : 1	150	2
* PA 50AM-63	3,4 : 1	120	7,6
* PA 50AM-80	5,3 : 1	90	10
* PA 50AM-200	8,4 : 1	60	7,5
PA 50AM-230	14,6 : 1	50	10,6
PA 50AM-250	20 : 1	50	6,2
* PA 65AM-80	1,6 : 1	80	20
* PA 65AM-200	2,5 : 1	60	17
* PA 65AM-230	4 : 1	50	24
PA 65AM-250	6 : 1	50	14
* PA 80AM-200	2 : 1	60	24
* PA 80AM-230	3,3 : 1	50	33
* PA 80AM-250	4,5 : 1	50	20
PA 80AM-310	9 : 1	50	32
* PA 100AM-200	1 : 1	60	37
* PA 100AM-230	1,8 : 1	50	52
* PA 100AM-255	2,5 : 1	50	52
* PA 100AM-310	5 : 1	50	50
* PA 140A-230	1,6 : 1	50	100
* PA 140A-255	2,2 : 1	50	100
* PA 140A-310	4 : 1	50	95

* Available with Atex 2G and 3G certification

MANUFACTURE

Manufactured in AISI 304 (only for PA140) / 316 stainless steel, mirror finish internally and externally. Rod and piston seal in rubber for foodstuff, Teflon or special materials.

Outlet port with female threaded fitting DIN 11851.

Pump components secured together by quick-release clamps.

Note: Available on request with different connections conforming to CLAMP - SMS - IDF - BS / RJT - DS standards.

CHARACTERISTICS

Double acting piston pump with pistons of various shapes depending on the liquids or pastes to be pumped. The pumps are fitted to the various pneumatic motors by clamps to facilitate their disassembly when cleaning.

Each pump is mainly made up of the following:

- In-take port with relative ball or mushroom valve
- Cylinder obtained from weld-free tubes
- Collar (rod seal holder and discharge port) generally obtained by casting
- Rod with valve carrying pumping piston

The pumps are normally light and very handy. The heavier pumps can be fitted on special trolleys (Art. 54), lifting vertically or with clamp (Art. 50-51-55-403) to secure the pump to the edge of the tank, to the container to be emptied or to the wall. The pumps are quickly and easily disassembled for their inspection and internal cleaning on a periodic basis. Each part of the pump can be reached and inspected. They can be used in environments with potentially explosive atmospheres as they are operated pneumatically. They can also be used in sterile environments as the air outlet can be conveyed outside the room. Their operation is adjustable likewise for most pneumatic pumps.

DIMENSIONS												
PUMPS	Z	A		B	Ø C	Outlet port	Inlet port			Max. consumption of air in l/min at feeding pressure	Weight kg	
	Ø Air inlet	Height between inlet and outlet ports				DNm	Long	Short			Long	Short
		Long	Short				D	D	DNa			
PA 20 A - 45	1/8" Gas	494	-	295	55	1/4" Gas F	Ø 27	-	-	17	3,5	-
PA 30 A - 45	1/8" Gas	1097	472	311	55	3/8" Gas F	Ø 34	Ø 39	1/2" Gas F	17	4	3,5
PA 50AM- 63	1/4" Gas	1194	302	441	68	DN32F/DIN 11851	Ø 51	-	DN32F/DIN 11851	42	12	10,5
PA 50AM- 80	1/4" Gas	1194	302	488	105	DN32F/DIN 11851	Ø 51	-	DN32F/DIN 11851	90	15	12,5
PA 50AM- 200	1/2" Gas	1194	302	639	228	DN32F/DIN 11851	Ø 51	-	DN32F/DIN 11851	104	26	22,5
PA 50AM- 230	1/2" Gas	1194	302	755	228	DN32F/DIN 11851	Ø 51	-	DN32F/DIN 11851	250	31,5	28
PA 50AM- 250	1/2" Gas	1194	302	608	249	DN32F/DIN 11851	Ø 51	-	DN32F/DIN 11851	200	27,5	24
PA 65AM- 80	1/4" Gas	1134	400	503	105	DN40F/DIN 11851	Ø 84	-	DN40F/DIN 11851	90	26	21
PA 65AM- 200	1/2" Gas	1134	400	648	228	DN40F/DIN 11851	Ø 84	-	DN40F/DIN 11851	104	35	30
PA 65AM- 230	1/2" Gas	1134	400	766	228	DN40F/DIN 11851	Ø 84	-	DN40F/DIN 11851	250	36,5	31,5
PA 65AM- 250	1/2" Gas	1134	400	647	249	DN40F/DIN 11851	Ø 84	-	DN40F/DIN 11851	200	36	31
PA 65AM- 255	1/2" Gas	1134	400	764	249	DN40F/DIN 11851	Ø 84	-	DN40F/DIN 11851	330	38,5	33,5
PA 80AM- 200	1/2" Gas	1131	397	705	228	DN50F/DIN 11851	Ø 89	-	DN50F/DIN 11851	104	39,7	35,2
PA 80AM- 230	1/2" Gas	1131	397	770	228	DN50F/DIN 11851	Ø 89	-	DN50F/DIN 11851	250	41,5	37
PA 80AM- 250	1/2" Gas	1131	397	704	249	DN50F/DIN 11851	Ø 89	-	DN50F/DIN 11851	200	40	35,5
PA 80AM- 255	1/2" Gas	1131	397	768	249	DN50F/DIN 11851	Ø 89	-	DN50F/DIN 11851	330	43,5	39
PA 80AM- 310	3/4" Gas	1131	397	783	280	DN50F/DIN 11851	Ø 89	-	DN50F/DIN 11851	620	47,5	43
PA100AM-200	1/2" Gas	900	470	697	228	DN50F/DIN 11851	Ø 120	-	DN65F/DIN 11851	104	50,7	41,7
PA100AM-230	1/2" Gas	900	470	762	228	DN50F/DIN 11851	Ø 120	-	DN65F/DIN 11851	250	52,5	43,5
PA100AM-255	1/2" Gas	900	470	760	249	DN50F/DIN 11851	Ø 120	-	DN65F/DIN 11851	330	54	45
PA100AM-310	3/4" Gas	900	470	760	280	DN50F/DIN 11851	Ø 120	-	DN65F/DIN 11851	620	59	50
PA 140 A - 230	1/2" Gas	1243	341	794	228	DN50F/DIN 11851	Ø 140	-	DN80F/DIN 11851	250	60,5	56,5
PA 140 A - 255	1/2" Gas	1243	341	792	249	DN50F/DIN 11851	Ø 140	-	DN80F/DIN 11851	330	62	58
PA 140 A - 310	3/4" Gas	1243	341	807	280	DN50F/DIN 11851	Ø 140	-	DN80F/DIN 11851	620	67	63

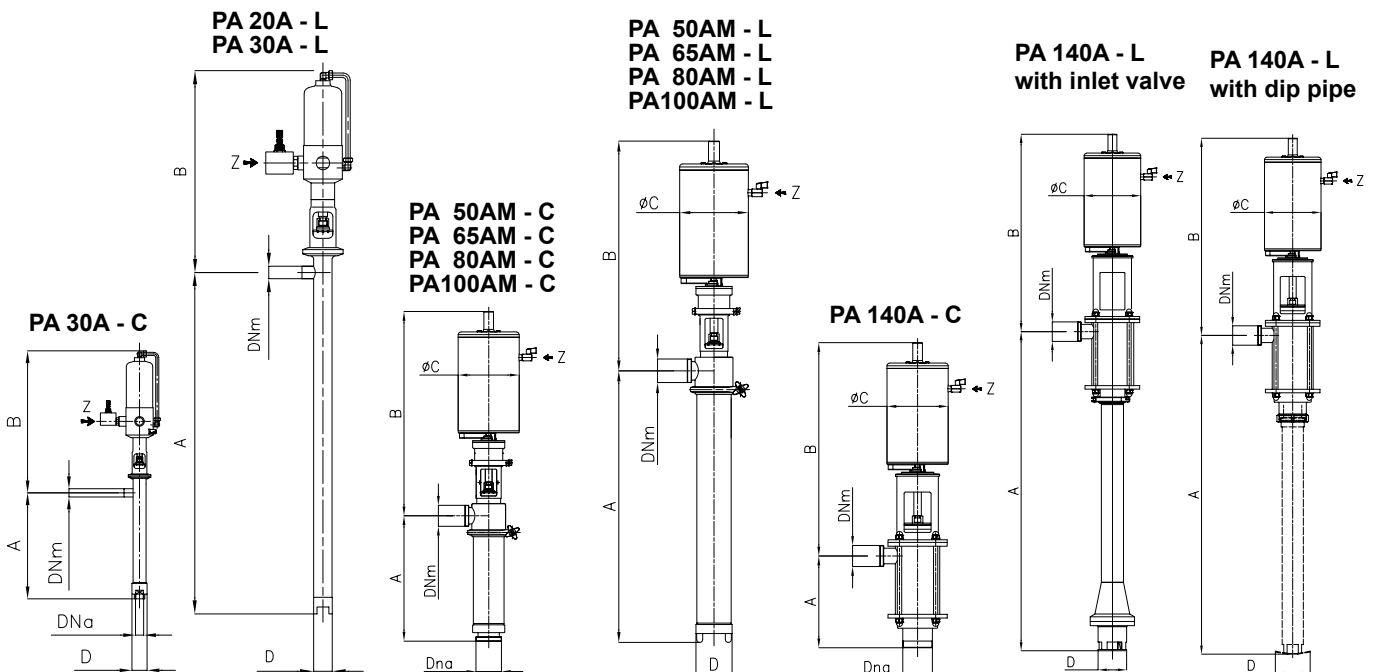



PERFORMANCES			
PUMPS	Pressure ratio	Recomm. max. cycles per minute	Max. flow rate l/min for viscosity of 1000 cP
* PA 40 I - 63	5,5 : 1	120	4,8
* PA 40 I - 80	8,8 : 1	90	6,4
* PA 40 I -200	14 : 1	60	4,7
PA 40 I -230	24,4 : 1	50	6,7
PA 40 I -250	33,2 : 1	50	4
* PA 65 I - 80	1,6 : 1	80	20
* PA 65 I -200	2,5 : 1	60	17
* PA 65 I -230	4 : 1	50	24
PA 65 I -250	6 : 1	50	14

* Available with Atex 2G and 3G certification

MANUFACTURE

In AISI 316 stainless steel.

Piston ring and rod seal in pure Teflon or special materials, pump components screwed together, outlet ports with cylindrical GAS threading.

CHARACTERISTICS

Double acting piston pump with pistons of various shapes depending on the liquids or pastes to be pumped. They are screwed to the pneumatic motor.

Each pump is mainly made up of the following:

- In-take port with relative ball or mushroom valve
- Cylinder obtained from weld-free tubes
- Collar (seal holder) achieved by investment casting
- Rod with valve carrying pumping piston

The pumps are normally light and very handy. The heavier pumps can be fitted on special trolleys (Art. 53) or with clamp (Art. 50-51-55-403) to secure the pump to the edge of the tank, to the container to be emptied or to the wall.

The pumps are easily disassembled for their inspection and internal cleaning on a periodic basis. Each part of the pump can be reached and inspected. They can be used in environments with potentially explosive atmospheres as they are operated pneumatically. Their operation is adjustable likewise for most pneumatic pumps.

DIMENSIONS												
PUMPS	Z	A		B	Ø C	DNm	Inlet port		Max. consumption of air in l/min at feeding pressure	Weight kg		
	Ø Air inlet	Height between inlet and outlet ports				Outlet port	Long	Short		Long	Short	
		Long	Short				D	DNa				
PA 40 I - 63	1/4" Gas	1020	230	474	68	1/2" Gas F	Ø 42	3/4" Gas F	42	10	8	
PA 40 I - 80	1/4" Gas	1020	230	505	105	1/2" Gas F	Ø 42	3/4" Gas F	90	12	10	
PA 40 I - 200	1/2" Gas	1020	230	638	228	1/2" Gas F	Ø 42	3/4" Gas F	104	25	23	
PA 40 I - 230	1/2" Gas	1020	230	703	228	1/2" Gas F	Ø 42	3/4" Gas F	250	28,5	26,5	
PA 40 I - 250	1/2" Gas	1020	230	637	249	1/2" Gas F	Ø 42	3/4" Gas F	200	26,5	24,5	
PA 65 I - 80	1/4" Gas	1132	407	488	105	1 1/2" Gas F	Ø 75	1" 1/2" Gas F	80	21	14,2	
PA 65 I - 200	1/2" Gas	1132	407	650	228	1 1/2" Gas F	Ø 75	1" 1/2" Gas F	104	34,1	27,3	
PA 65 I - 230	1/2" Gas	1132	407	767	228	1 1/2" Gas F	Ø 75	1" 1/2" Gas F	250	36,8	30	
PA 65 I - 250	1/2" Gas	1132	407	649	249	1 1/2" Gas F	Ø 75	1" 1/2" Gas F	200	35,8	29	
PA 65 I - 255	1/2" Gas	1132	407	765	249	1 1/2" Gas F	Ø 75	1" 1/2" Gas F	330	38,8	32	

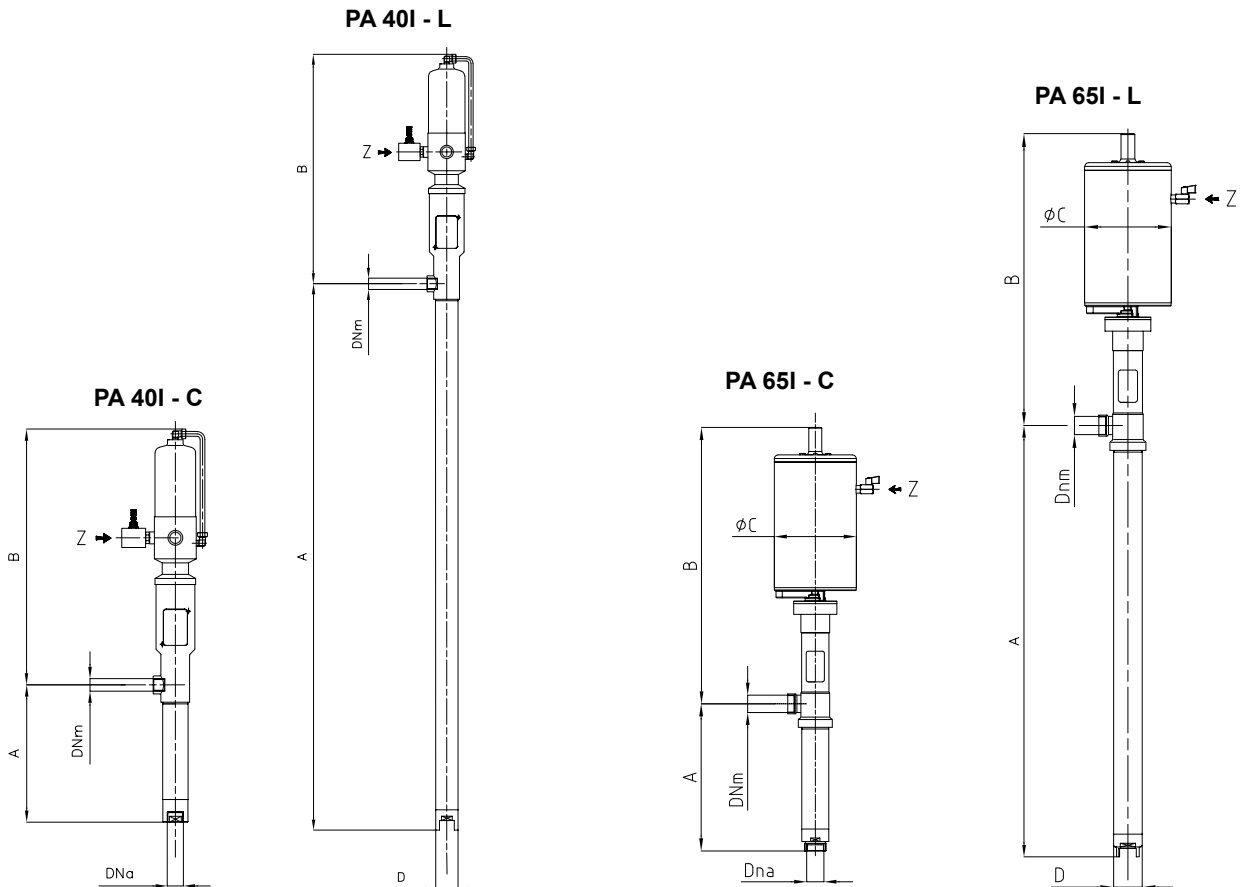



MANUFACTURE

In AISI 316 stainless steel in aluminium and galvanised iron.

Piston ring and rod seal in PTFE, pump components screwed together, discharge ports with cylindrical GAS threading

CHARACTERISTICS

Pneumatic piston pumps, light-weight for lighter duty requirements. They are screwed to the pneumatic motor.

Each pump is made up of the following:

- In-take port with ball or mush-room valve
- Cylinder obtained from weld-free tubes
- Pump casing (rod seal holder and outlet) achieved by casting.

- Rod with pumping piston and valve.

- They are easy to assemble, light and handy. Likewise for all our pneumatic pumps their operation is adjustable.

- They can be secured with various types of clamps, brackets or trolleys, supplied as our accessories.

- On request in compliance with Atex directive in category 2G and 3G for uses in zone 1 and 2.

- On request in compliance with Atex directive in category 2G and 3G for uses in zone 1 and 2.

PERFORMANCES

PUMPS	Pressure ratio	Recomm. max. cycles per minute	Max. flow rate l/min for viscosity of 1000 cP
PAR 30 - 50	4 : 1	180	7,5
PAR 40 - 50	2 : 1	180	12
PAR 50 - 50	1 : 1	180	25
PAR 50 - 65	2 : 1	160	25
PAR 65 - 50	0,7 : 1	180	55
PAR 65 - 65	0,7 : 1	160	55

PAR - C

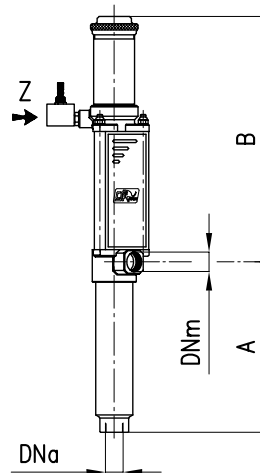

PAR - L

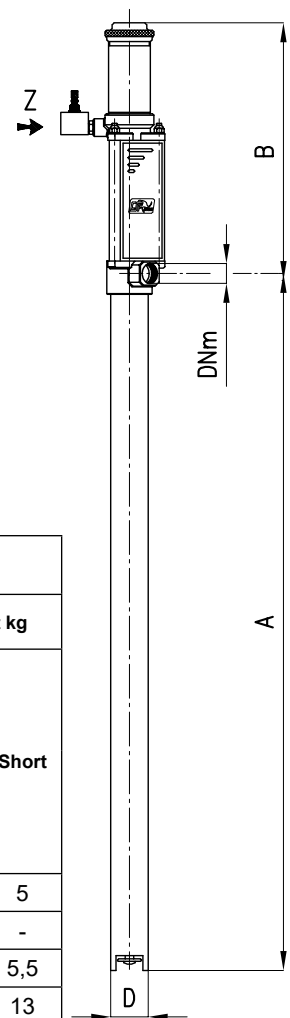

DIMENSIONS

PUMPS	Z	A		B	Outlet port	Inlet port		Max. consumption of air in l/min at feeding pressure	Weight kg	
		Height between inlet and outlet ports				Long	Short		Long	Short
	Ø Air inlet	Long	Short	DNm	D	DNa				
PAR 30 - 50	1/4" Gas	1041	211	373	3/4" Gas F	Ø 34	1/2" Gas F	25	6	5
PAR 40 - 50	1/4" Gas	1027	259	373	3/4" Gas F	Ø 42	3/4" Gas F	25	7	-
PAR 50 - 50	1/4" Gas	1005	265	368	3/4" Gas F	Ø 54	3/4" Gas F	25	8,5	5,5
PAR 50 - 65	3/8" Gas	1062	339	469	1 1/2" Gas F	Ø 54	3/4" Gas F	45	15,5	13
PAR 65 - 50	3/8" Gas	1231	-	471,5	1 1/2" Gas F	Ø 54	-	25	15	-
PAR 65 - 65	3/8" Gas	1103	324	469	1 1/2" Gas F	Ø 88	2" Gas F	45	17	14,5

ACCESSORIES



Art. 54
Vertical lift, balanced with counterweight.

Art. 50
2" threaded clamp to fix PAPA/PAR pumps to standard barrels.



Art. 51
Double clamp to fix the pumps on tanks or containers edge.



Art. 70
Tripod with wheels for short pumps.
(Available from size PA 50AM)



Art. 55
Wall brackets for fixing pumps to the wall.



Art. 59-60
Scraping plate to be applied to the short pump.



Art. 53
Fixed tripod for short pumps.



Art. 52
Bag control linear flow outlet product.



Art. 58
Automatic electrovalve to close/open airflow.



TECHNICAL FEATURES OF FAIR-OPERATED MOTOR PAA SERIES

Double acting reciprocating motor with air distributing valve. Air inlet provided with shutting regulator to change the stroke frequency.

The speed is adjustable according to the models from 10 to 150 strokes by turning the regulator.

It is available in 8 different models and with corresponding reduced connections and can be coupled with a number of pumps, thus offering various combinations.

TECHNICAL FEATURES OF FAIR-OPERATED MOTOR PAR SERIES

Double acting reciprocating motor with spring return device. Air inlet provided with shutting regulator to change the stroke frequency.

The speed is adjustable according to the models from 10 to 180 strokes by turning the regulator.

Made of brass, aluminium and steel, it is built-in the pump and available in 6 models.

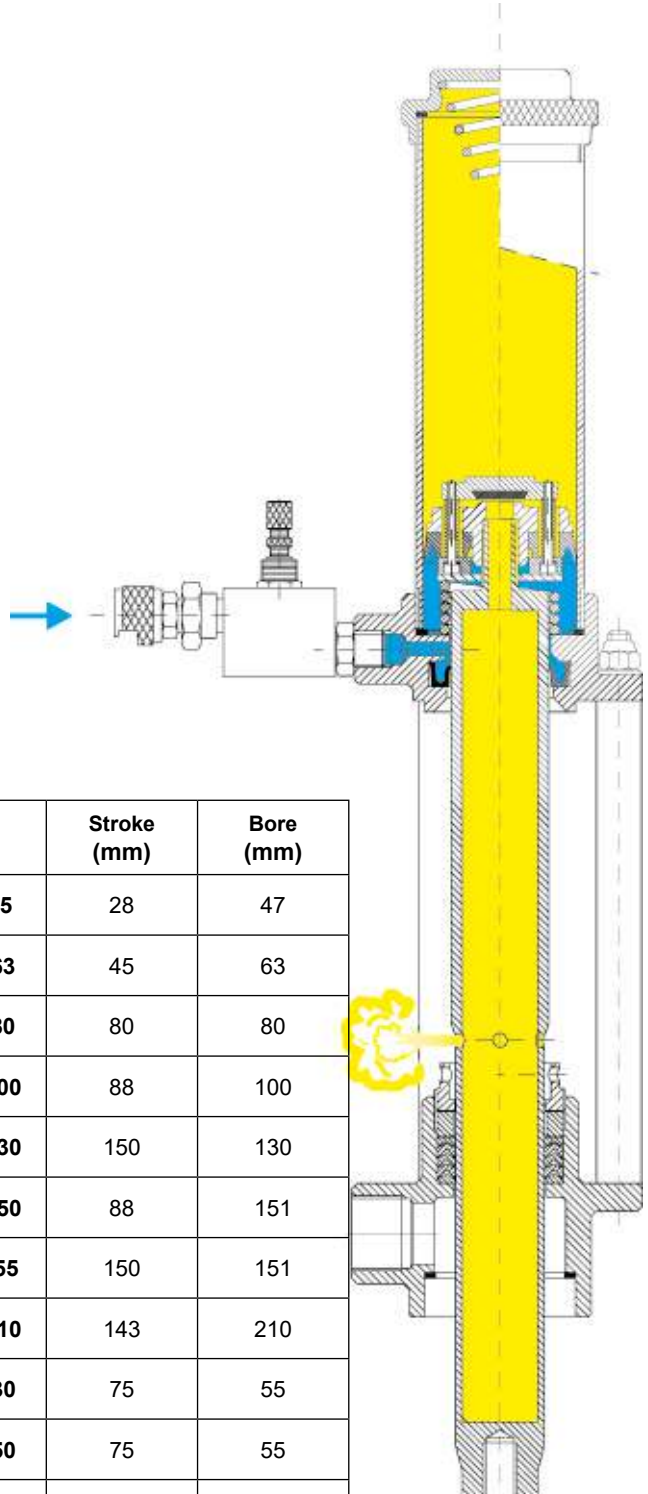
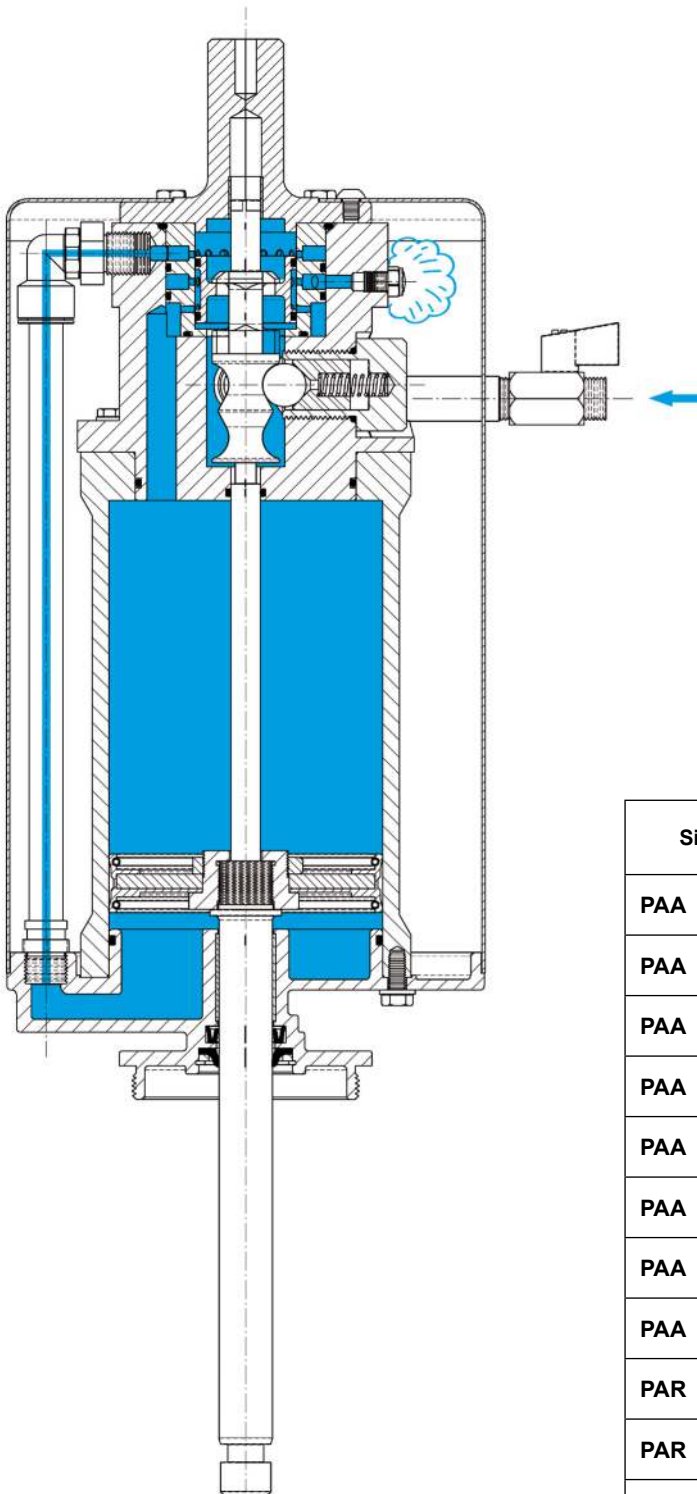

Size	Stroke (mm)	Bore (mm)
PAA 45	28	47
PAA 63	45	63
PAA 80	80	80
PAA 200	88	100
PAA 230	150	130
PAA 250	88	151
PAA 255	150	151
PAA 310	143	210
PAR 30	75	55
PAR 50	75	55
PAR 65	85	75

PAA

Pneumatic motor with adjustable speed and automatic stroke and return device



The motor pump rods are coupled by means of bayonet type connection to be screwed or clamped to the structures.

PA.A SANITARY EXECUTION

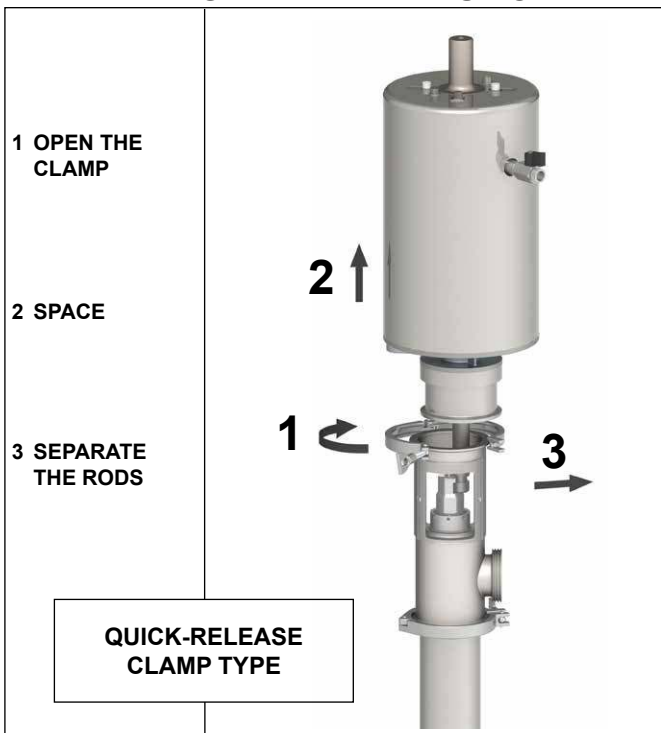

PA.I INDUSTRIAL EXECUTION (While stocks last)

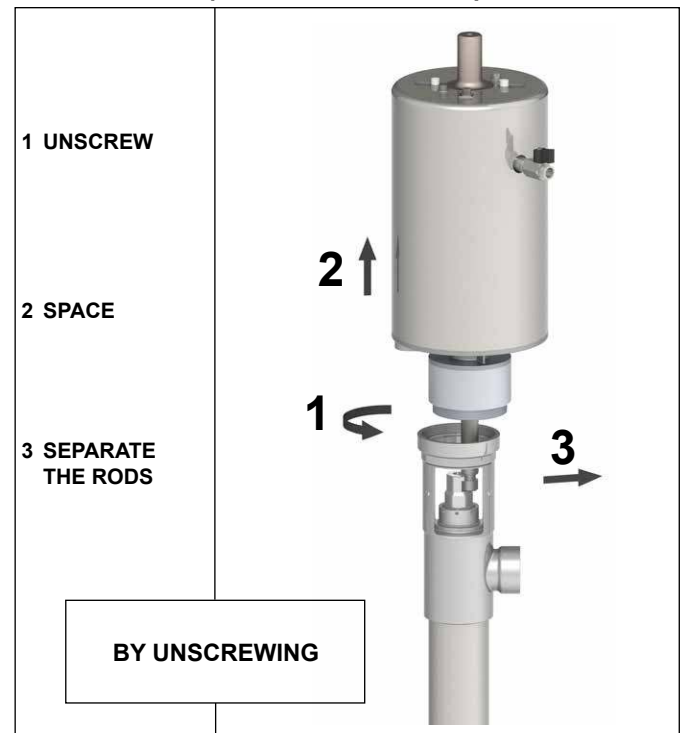

PAR INDUSTRIAL EXECUTION

PAR

Pneumatic motor with adjustable speed and spring return device



The motor is secured to the pump by means of some connection supports, whereas the rod is screwed.

* To be able to separate the motor / pump the cylinder and tie rod must first be unscrewed.

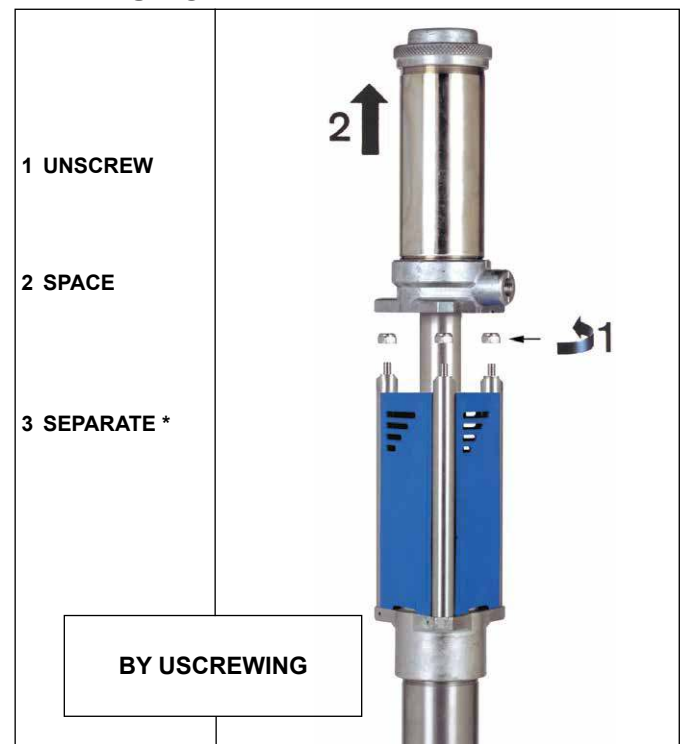

PUMP CODES GUIDE

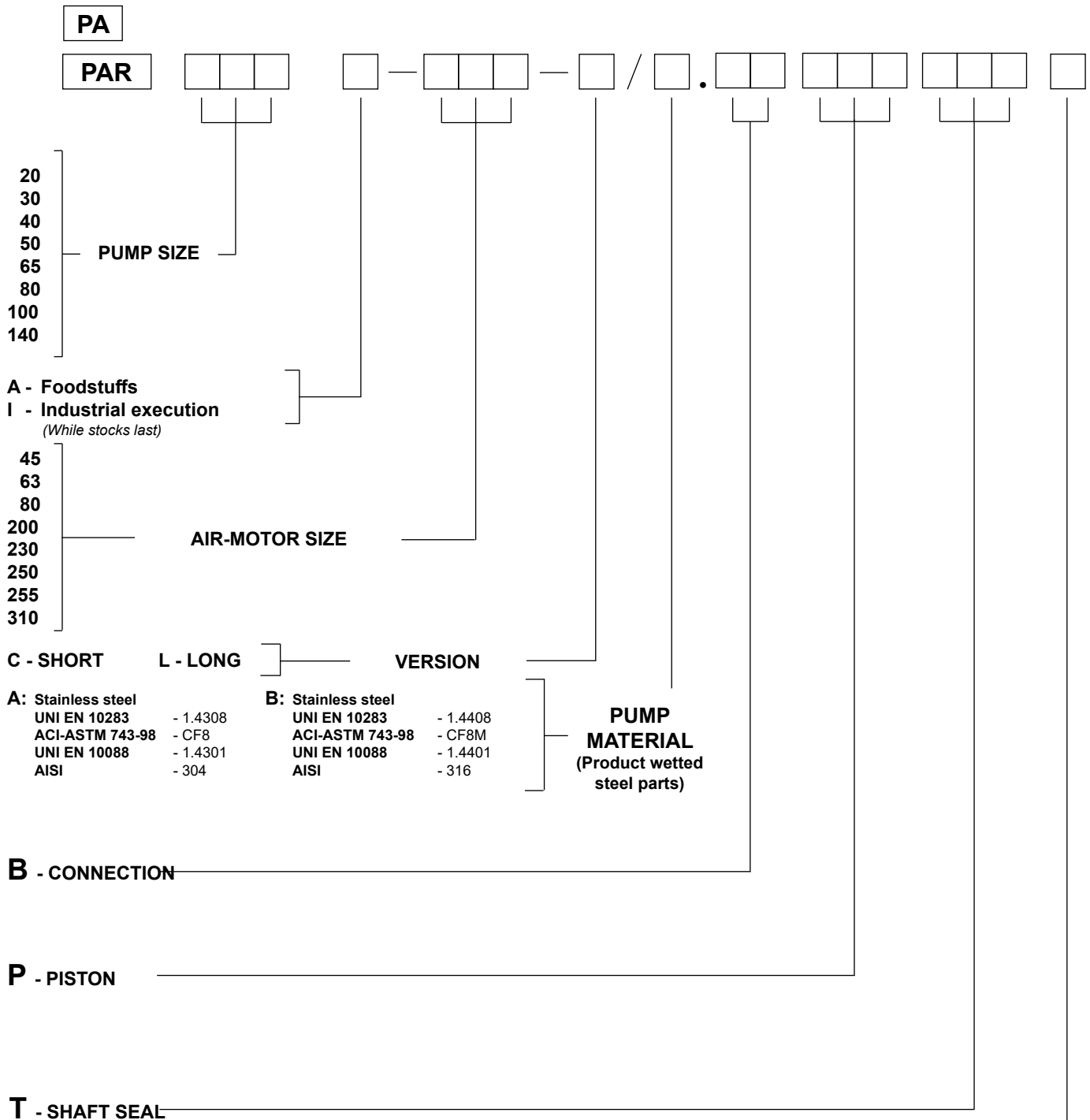

- PUMP SIZE**
- 20
 - 30
 - 40
 - 50
 - 65
 - 80
 - 100
 - 140

- A - Foodstuffs**
I - Industrial execution
(While stocks last)

- AIR-MOTOR SIZE**
- 45
 - 63
 - 80
 - 200
 - 230
 - 250
 - 255
 - 310

- VERSION**
- | | |
|---------------------------|---------------------------|
| C - SHORT | L - LONG |
| A: Stainless steel | B: Stainless steel |
| UNI EN 10283 - 1.4308 | UNI EN 10283 - 1.4408 |
| ACI-ASTM 743-98 - CF8 | ACI-ASTM 743-98 - CF8M |
| UNI EN 10088 - 1.4301 | UNI EN 10088 - 1.4401 |
| AISI - 304 | AISI - 316 |

PUMP MATERIAL
 (Product wetted steel parts)

B - CONNECTION

P - PISTON

T - SHAFT SEAL

- SPECIAL EXECUTIONS**
- | | |
|---|------------|
| Lubricating cup on seal | = B |
| Suction bag protection | = P |
| Cylinder with heating jacket | = X |
| Horizontal mounting execution | = O |
| Barrel execution | = F |
| Kit for lifting device | = C |
| Chromium coated rod | = D |
| Ceramic coated rod | = H |
| Non-chromium coated rod | = N |
| Special length "A" | = Z |
| Conical suction port | = Q |
| Suction bag protection+chromium coated rod | = 1 |
| Suction bag protection+ceramic coated rod | = 2 |
| Suction bag protection+ non-chromium coated rod | = 3 |
| Suction bag protection+barrel execution | = 4 |
| Cylinder and casing with jacket | = 5 |
| Kit for lifting device+conical suction port | = 6 |
| Note: For other executions - not foreseen | = Y |

Example: PA 50AM-200-C/B.B5P00T00X

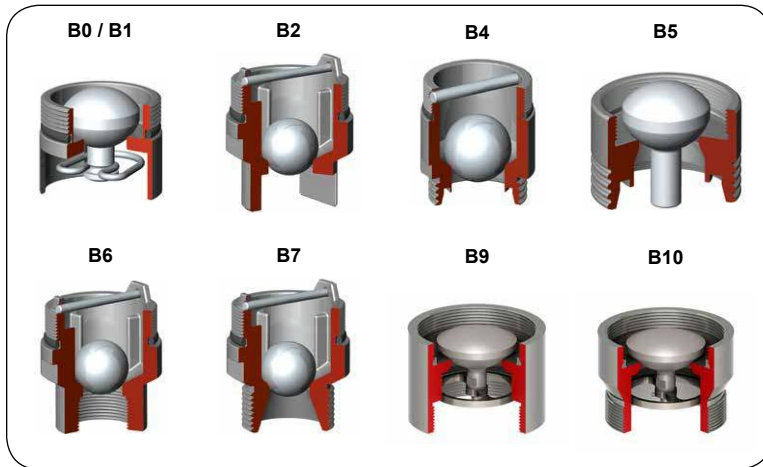

CONNECTIONS

- B0** - Immersed mushroom valve (P.T.F.E)
- B1** - Immersed mushroom valve (S.S.I)
- B2** - Immersed ball valve (S.S.)
- B4** - DIN male with ball valve (S.S.)
- B5** - DIN with mushroom valve (S.S.)
- B6** - GAS female with ball valve (S.S.)
- B7** - GAS male with ball valve (S.S.)
- B9** - GAS female with mushroom valve (S.S.)
- B10** - GAS male with mushroom valve (S.S.)

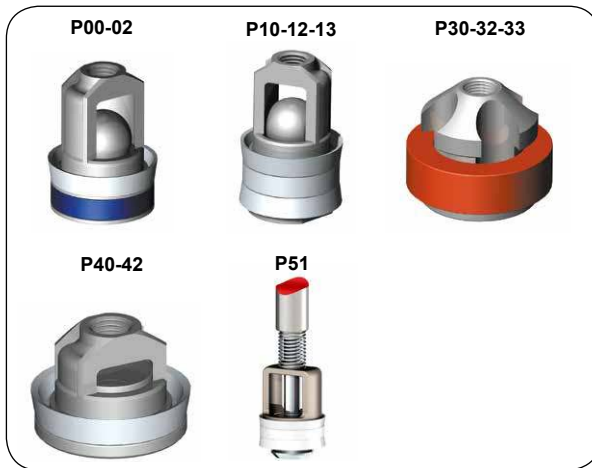

PISTONS

- P00** - Ball piston with 1 seal (P.T.F.E)
- P02** - Ball piston with 1 seal (Vulcolan)
- P10** - Ball piston with 2 seals (P.T.F.E)
- P12** - Ball piston with 2 seals (Vulcolan)
- P13** - Ball piston with 2 seals (Fluorocarbon)
- P30** - With ring (P.T.F.E)
- P32** - With ring (Vulcolan)
- P33** - With ring (Rubber)
- P40** - With washer and 1 seal (P.T.F.E)
- P42** - With washer and 1 seal (Vulcolan)
- P51** - Moving piston



SHAFT SEALS

- T00** - "Chevron" (P.T.F.E)
- T04** - "Chevron" (Algoflon)
- T05** - "Chevron" (PTFE - Algoflon)
- T10** - "DI" ring (NBR)
- T11** - "DI" ring (Fluorocarbon)
- T12** - "FM" ring + "DI" ring (P.T.F.E)
- T13** - "FM" ring + "Chevron" (P.T.F.E)
- T20** - "H" ring (NBR)
- T21** - "H" ring (Fluorocarbon)
- T22** - "H" ring (P.T.F.E.)
- T25** - "H" ring (NBR) + "Chevron"
- T26** - "H" ring (Fluorocarbon) + "Chevron"
- T27** - "H" ring + "Chevron" (P.T.F.E.)
- T30** - "H" ring + "DI" ring (NBR)
- T31** - "H" ring + "DI" ring (Fluorocarbon)
- T39** - "Ecopur" + "DI" ring (Viton)
- T40** - "Ecopur" + "DI" ring (NBR)
- T42** - "Ecopur" + "Chevron"
- T50** - "Hi-Clean" ring + bush

VARIOUS EXECUTIONS

Air-operated piston pump with mobile lift.

With pneumatic cylinder and control panel.



It is realised in a manual sliding model with counterweight for balancing.



Short air-operated piston pump on tripod with wheels.



Short air-operated piston pump with scraping plate to empty barrels or cylindrical tanks. For high viscosity products.





Pneumatic lift to empty barrels.



Unit with double pneumatic pistons for vessels with a diameter exceeding 700 mm, including an air operated piston pump and scraper plate. For mixtures, jams, creams etc... to be transferred after processing.



Pneumatic lift with scraper plate for vessels with diameter up to 700 mm.