



Operation and Maintenance

B Series

Lobe Positive Displacement

Group Pump Unit

Translation from the Original Instructions

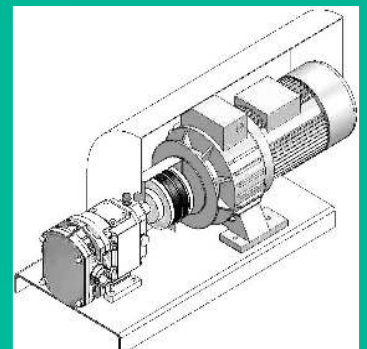

© Copyright by
O.M.A.C. s.r.l.
Via Giovanni Falcone, 8
42048 RUBIERA (RE) – ITALY
Printed directly by the company
Revision 4 - January 2010

SUMMARY

<i>INTENDED USE</i>	VII
<i>EC DECLARATION OF CONFORMITY (EXAMPLE)</i>	IX
<i>HOW TO CONSULT AND KEEP THIS DOCUMENTATION</i>	X
<i>SYMBOLS USED</i>	X
<i>KEEPING THE MANUAL</i>	XI
<i>LABLES APPLIED</i>	XI
<i>TERMS AND DEFINITIONS</i>	XII

CHAPTER 1: MACHINE AND PUMPED FLUID SPECIFICATIONS

		Chap.1-pag.1
1.1	Envisioned duration	Chap.1-pag.1
1.2	Technical description of the machine	Chap.1-pag.1
1.2.1	Operation principle of the B Series LDPU	Chap.1-pag.1
1.2.2	B Series LDPU coding	Chap.1-pag.2
1.3	Technical features	Chap.1-pag.4
1.3.1	Technical features of the B Series LDPU	Chap.1-pag.5
1.3.2	Variation of maximum operating pressure according to the temperature	Chap.1-pag.5
1.3.3	Motorization and transmission coupling technical features	Chap.1-pag.6
1.3.4	Rotor clearances	Chap.1-pag.6
1.3.5	Rotor geometry	Chap.1-pag.6
1.3.6	Tightening torque	Chap.1-pag.7
1.3.7	Mechanical seal overall dimensions	Chap.1-pag.7
1.3.8	Weights and dimensions table of the B Series LDPU	Chap.1-pag.8
1.3.9	Dimensions of pumping bodies couplings, equipped with heating/cooling chamber and seals flushing	Chap.1-pag.10
1.3.10	Suction inlet dimensions in "widened rectangular inlet" version of the B Series LDPU	Chap.1-pag.10
1.3.11	Bearings	Chap.1-pag.11
1.3.12	Lubricants used and quantities	Chap.1-pag.11
1.4	Intended use	Chap.1-pag.11
1.4.1	Recommended use guidelines for the transfer of the some types of processed fluid	Chap.1-pag.12
1.5	Material specifications	Chap.1-pag.14
1.6	Occupied workplaces	Chap.1-pag.14
1.7	Indication of the safety systems	Chap.1-pag.14
1.7.1	Flexible coupling protection	Chap.1-pag.15
1.7.2	Emergency stop	Chap.1-pag.15
1.7.3	Seals protections	Chap.1-pag.15
1.7.4	Optional features: full fairing	Chap.1-pag.15
1.7.5	Optional features: electric safety devices and pressure limiters	Chap.1-pag.15
1.8	Noise and vibrations emitted	Chap.1-pag.16
1.9	Use of the personal protection equipment	Chap.1-pag.16
1.10	Personnel training	Chap.1-pag.16
1.11	B Series LDPU optional features	Chap.1-pag.16
1.11.1	Pump unit in aseptic version	Chap.1-pag.16
1.11.2	Pump unit with widened rectangular inlet	Chap.1-pag.17
1.11.3	Pump unit with heating / cooling chamber and front cover	Chap.1-pag.17
1.11.4	Pump unit with mechanical safety valve on cover	Chap.1-pag.17
1.11.5	Pump unit with pneumatic safety valve on cover	Chap.1-pag.18
1.11.6	Pump unit with external mechanical bridge safety valve	Chap.1-pag.18
1.12	LDPU optional features	Chap.1-pag.18
1.12.1	Motorized B Series LDPU on fixed base	Chap.1-pag.18
1.12.2	Motorized B Series LDPU on trolley base	Chap.1-pag.18

CHAPTER 2: TRANSPORTATION OF THE B SERIES LDPU

		Chap.2-pag.1
2.1	Hoisting and transportation	Chap.2-pag.1
2.2	Delivery and unpacking	Chap.2-pag.2
2.3	Conditions for storage or extended interruptions of service	Chap.2-pag.2
2.4	Packaging composition for future handling	Chap.2-pag.3
2.5	Handling the LDPU without packaging	Chap.2-pag.3

CHAPTER 3: INSTALLATION OF THE B SERIES LDPU

		Chap.3-pag.1
3.1	Destination and intended environments	Chap.3-pag.1
3.2	Environmental conditions	Chap.3-pag.1
3.2.1	Room lighting	Chap.3-pag.1
3.3	Installation and assembly	Chap.3-pag.1
3.3.1	Notes for the installer	Chap.3-pag.2
3.3.2	Preliminary checks	Chap.3-pag.2
3.3.3	Installation	Chap.3-pag.2
3.3.4	Accessories fitting	Chap.3-pag.5
3.4	Cleaning and Hygiene of the LDPU	Chap.3-pag.9
3.4.1	LDPU for alimentary use	Chap.3-pag.9
3.4.1.1	External cleaning instructions	Chap.3-pag.10
3.4.1.2	Internal cleaning instructions	Chap.3-pag.10

SUMMARY

	3.4.1.2.1	Internal cleaning :CIP (Cleaning In Place) / SIP (Sterilising In Place)	Chap.3-pag.10
	3.4.1.2.2	Internal cleaning: manual cleaning	Chap.3-pag.11
3.4.2		LDPU for chemical use	Chap.3-pag.12
	3.4.2.1	External cleaning instructions	Chap.3-pag.12
	3.4.2.2	Internal cleaning instructions	Chap.3-pag.12
	3.4.2.2.1	Internal cleaning: CIP (Cleaning In Place)	Chap.3-pag.13
	3.4.2.2.2	Internal cleaning: manual cleaning	Chap.3-pag.13
3.5		Connection to energy sources	Chap.3-pag.14
	3.5.1	Connection to electrical system	Chap.3-pag.14
	3.5.2	Connection to the hydraulic system	Chap.3-pag.14
	3.5.3	Connection to the pneumatic system	Chap.3-pag.15
3.6		Use of lubricants	Chap.3-pag.16
3.7		Installation and pre-start check: operation test	Chap.3-pag.16
CHAPTER 4: USE OF THE B SERIES LDPU			Chap.4-pag.1
4.1		Inteded use	Chap.4-pag.1
4.2		Controls	Chap.4-pag.2
4.3		LDPU volumetric capacity adjustment methods	Chap.4-pag.3
	4.3.1	Adjustment of the volumetric capacity with the inverter	Chap.4-pag.3
	4.3.2	Adjustment of the volumetric capacity via mechanical speed controller	Chap.4-pag.3
4.4		Work cycle description	Chap.4-pag.4
4.5		Cycle start instructions	Chap.4-pag.4
	4.5.1	Preliminary operations: check list	Chap.4-pag.4
	4.5.2	First start-up	Chap.4-pag.5
4.6		Stopping instructions	Chap.4-pag.5
4.7		Instructions for restarting after a stop	Chap.4-pag.5
4.8		Switch-off	Chap.4-pag.5
4.9		Emptying	Chap.4-pag.5
4.10		Residual risks	Chap.4-pag.6
4.11		Dangers generated by use	Chap.4-pag.6
4.12		Prohibited use	Chap.4-pag.6
4.13		Management of emergency situations	Chap.4-pag.6
CHAPTER 5: MAINTENANCE OF THE B SERIES LDPU			Chap.5-pag.1
5.1		Troubleshooting and solving problems	Chap.5-pag.1
5.2		Instruction for carrying out checks	Chap.5-pag.4
	5.2.1	Daily checks	Chap.5-pag.5
	5.2.2	Weekly checks	Chap.5-pag.5
	5.2.3	Six monthly checks	Chap.5-pag.5
5.3		Periodic check of the safety and emergency devices	Chap.5-pag.5
5.4		Indication of dangerous temperatures	Chap.5-pag.5
5.5		Oils present	Chap.5-pag.5
5.6		Test and checks	Chap.5-pag.5
	5.6.1	Electrical checks	Chap.5-pag.5
	5.6.2	Single mechanical seals	Chap.5-pag.5
	5.6.3	Mechanical seals with flushing	Chap.5-pag.6
	5.6.4	Mechanical seals balancing	Chap.5-pag.6
	5.6.5	Packing seals	Chap.5-pag.6
5.7		Disassembly and assembly operations of B100 size pump	Chap.5-pag.7
	5.7.1	Disassembly of the pumping body	Chap.5-pag.8
	5.7.2	Assembly of the pumping body	Chap.5-pag.8
	5.7.3	Disassembly of the bearings box	Chap.5-pag.9
	5.7.4	Assembly of the bearings box	Chap.5-pag.9
	5.7.5	Disassembly of the lip seals	Chap.5-pag.10
	5.7.6	Assembly of the lip seals	Chap.5-pag.10
5.8		Disassembly and assembly operations of B1 B2 B3 B4 B470 B490 size pump	Chap.5-pag.11
	5.8.1	Disassembly of the pumping body	Chap.5-pag.13
	5.8.2	Assembly of the pumping body	Chap.5-pag.13
	5.8.3	Disassembly of the bearings box	Chap.5-pag.13
	5.8.4	Assembly of the bearings box	Chap.5-pag.14
5.9		Disassembly and assembly operations of B550 B660 B680 size pump	Chap.5-pag.16
	5.9.1	Disassembly of the pumping body	Chap.5-pag.18
	5.9.2	Assembly of the pumping body	Chap.5-pag.18
	5.9.3	Disassembly of the bearings box	Chap.5-pag.19
	5.9.4	Assembly of the bearings box	Chap.5-pag.19
5.10		Post maintenance check	Chap.5-pag.20
CHAPTER 6: DECOMMISSIONING OF THE B SERIES LDPU			Chap.6-pag.1
6.1		Disconnection from energy sources	Chap.6-pag.1

SUMMARY

6.2	Disassembly	Chap.6-pag.2
6.3	Storage after its use	Chap.6-pag.2
6.4	Demolition and disposal	Chap.6-pag.2

CHAPTER 7: SPARE PARTS OF THE B SERIES LDPU

7.1	List of spare parts and section drawings of the lobe displacement pump	Chap.7-pag.1
7.1.1	B100: Spare parts list	Chap.7-pag.1
7.1.1.1	Pump exploded view drawing	Chap.7-pag.2
7.1.1.2	Spare parts names and codes	Chap.7-pag.2
7.1.1.3	Seals section drawings	Chap.7-pag.3
7.1.1.4	Gasket o-ring codes for mechanical seals	Chap.7-pag.4
7.1.2	B105 B110 B115: Spare parts list	Chap.7-pag.4
7.1.2.1	Pump exploded view drawing	Chap.7-pag.5
7.1.2.2	Spare parts names and codes	Chap.7-pag.5
7.1.2.3	Seals section drawings	Chap.7-pag.6
7.1.2.4	Gasket o-ring codes for mechanical seals	Chap.7-pag.8
7.1.2.5	Balancing ring codes for single and flushed mechanical seals	Chap.7-pag.9
7.1.2.6	Single and double mechanical seals codes	Chap.7-pag.10
7.1.3	B215 B220 B325 B330 B390 B430 B440 B470 B490: Spare parts list	Chap.7-pag.10
7.1.3.1	Pump exploded view drawing	Chap.7-pag.11
7.1.3.2	Spare parts names and codes	Chap.7-pag.11
7.1.3.3	Seals section drawings	Chap.7-pag.12
7.1.3.4	Gasket o-ring codes for mechanical seals	Chap.7-pag.16
7.1.3.5	Balancing ring codes for single and flushed mechanical seals	Chap.7-pag.18
7.1.3.6	Single and double mechanical seals codes	Chap.7-pag.18
7.1.4	B550 B660 B680: Spare parts list	Chap.7-pag.19
7.1.4.1	Pump exploded view drawing	Chap.7-pag.20
7.1.4.2	Spare parts names and codes	Chap.7-pag.20
7.1.4.3	Seals section drawings	Chap.7-pag.22
7.1.4.4	Gasket o-ring codes for mechanical seals	Chap.7-pag.24
7.1.4.5	Balancing ring codes for single and flushed mechanical seals	Chap.7-pag.27
7.1.4.6	Single and double mechanical seals codes	Chap.7-pag.27
7.1.5	Name and codes of pumping bodies	Chap.7-pag.28
7.1.6	Codes of the springs used in the mechanical safety valve	Chap.7-pag.29
7.1.7	Codes of the springs used in the external bridge mechanical safety valve	Chap.7-pag.30
7.2	Recommended spare parts	Chap.7-pag.30
7.3	How to order spare parts	Chap.7-pag.30

CHAPTER 8: ASSISTANCE**Chap.8-pag.1****CHAPTER 9: WARRANTY OF THE B SERIES LDPU****Chap.9-pag.1**





INTENDED USE

The "B Series Lobe Positive Displacement Pump Unit", manufactured and marketed by O.M.A.C. s.r.l., which in this documentation will be indicated with the abbreviation LDPU, has been designed and made to be assembled in industrial plants owned by third parties, to transfer volumes of fluid, compatible with the materials used during the construction of this machine: section 1.4.1 lists the recommended operational features of the LDPU, depending on the fluid.

The LDPU requires compliance with all technical indications in this use and maintenance manual, which in this documentation will be indicated with the abbreviation OMM, for its proper installation.

In general, the fluid must meet the following specifications:

Fluid properties and range of use:

- 1) **TEMPERATURE: from -35°C to +180°C**
- 2) **VISCOSITY: Maximum 200'000cPs with forced feeding**
- 3) **HARD PARTICLE SIZE: Maximum 80% of clearance between rotors (see sect.1.3.4)**

The LDPU has been designed and made for two types of use:

- **alimentary use:**
- **chemical use.**



WARNING:

The LDPU, for alimentary use, has been made to ensure a hygienic standard equal to **LEVEL 1**, on the basis of **UNI EN 13951**.

The LDPU for alimentary use and for chemical use has been designed to transfer volumes of fluid without altering the organoleptic properties not the physical properties.



WARNING:

During its normal use, the LDPU for alimentary use and chemical use does not alter the organoleptic characteristics not the physical characteristics of the fluid.

Every LDPU comes with a **technical sheet** indicating the operational features in relation to the fluid that must be handled (name of the fluid, viscosity range, capacity range, speed range, temperature range), as declared at the time of purchase by the Customer.

Section 1.3 shows a facsimile of the LDPU technical sheet.

Every modification to what is indicated in the specific technical sheet or variation of the machine operating parameters must be authorised in writing by O.M.A.C. s.r.l.; the absence of such authorisation is deemed "improper use" and will void any warranty or liability under way between Manufacturer and Customer.



DANGER:

Any use of the LDPU in conditions other than those indicated in "Fluid properties and range of use" and in conditions other than those indicated in the machine technical sheet is forbidden, without explicit written authorisation, issued by O.M.A.C. s.r.l.

The LDPU for alimentary use and for chemical use has NOT been designed nor built to handle pharmaceutical, explosive, etc. fluids, and in general fluids that do not comply with the indications of the specific technical sheet. In addition, the LDPU for alimentary use and chemical use has NOT been designed nor built to handle what is indicated in Regulation (EC) No. 1005/2009 of the European Parliament and the Council of 16 September, 2009, on substances that deplete the ozone layer.



ATTENTION:

It is forbidden to use the LDPU for alimentary use and chemical use to transfer the substances listed in Annex I of **Regulation No. 1005/2009**.

The pumping part of the LDPU is made up of the rotorcase, in which two rotors are housed (sect. 1.3.5 lists the types of rotors used), which rotate synchronised in the opposite direction to each other.

The rotorcase receives the process fluid from the suction inlet, originating from the plant of the Customer. During the operation of the LDPU, the cavities between the lobes of the rotors are filled with fluid and the counter-rotation of the rotors transfers the fluid to the delivery outlet of the rotorcase, channelling it in the plant where the LDPU is installed.



(Declaration of conformity to be attached)

EC DECLARATION OF CONFORMITY

EC Declaration of conformity (Machinery Directive 2006/42/EC)

We, O.M.A.C. s.r.l., with registered office in Via Falcone n.8 - 42048 Rubiera (RE) – Italy, Tel. 0522/629371 - Fax. 0522/628980
E-mail: info@omacpompe.com Website: www.omacpompe.com

hereby declare under our exclusive responsibility that:

Mrs Paola Zavaroni, Via Falcone, 8 - 42048 Rubiera (RE) Italy, is authorised to establish and keep the technical documentation relative to the machine called

“MOTORIZED B SERIES LOBE POSITIVE DISPLACEMENT PUMP UNIT”
or “MOTORIZED B SERIES LOBE POSITIVE DISPLACEMENT PUMP UNIT WITH ELECTRIC PANEL”
or “B SERIES LOBE POSITIVE DISPLACEMENT PUMP UNIT complete with “TRANSMISSION DEVICE”

Model: _____ Serial No: _____ Specifications: _____

Date of issue: _____

designed and built for pumping, in a third party plant, a medium (alimentary fluid / chemical fluid) to which this declaration refers to.

The machine is compliant with the safety requirements provided by Directive 2006/42/EC

with Regulation EC No.1935/2004 

and with Directives: 2006/95/EC – 2004/108/EC – 94/9/EC
and in accordance with the provisions of the following harmonised standards:

*** REFERENCE STANDARDS***

This machine is equipped with:

Gear Unit/Speed Controller/Gear motor: _____ Supplier: _____ Specifications: _____
Electric motor/Hydraulic motor: _____ Supplier: _____ Specifications: _____
Flexible transmission coupling: _____ Supplier: _____

NOTE: any modifications to the machine, to which this declaration refers to, to the processing fluid and conditions of use of the process fluid, specified in the relative technical sheet, will make this declaration null and void. O.M.A.C. s.r.l. does not assume any liability arising from the incompatibility between the process fluid and materials which make up the machine, subject of this declaration, if the customer does not specify the particulars of the process fluid and its physical characteristics.

RUBIERA (RE)

The Legal Representative

Date _____

Signature _____

HOW TO CONSULT AND KEEP THIS DOCUMENTATION

This OMM is a document written by O.M.A.C. s.r.l. and is relative to the installation, safe use and maintenance of the LDPU, in this sense, this documentation, complete with the use and maintenance manuals supplied by the manufacturers of the single components, is an integral part of the LDPU.

The purpose of all the documentation mentioned above is to put the users of the LDPU in the conditions to operate safely, thus putting in place clear rules of use; this documentation must be carefully read and understood by the users.

Please note that the specifications carried on all the use and maintenance manuals, with reference to this machine, are designed to ensure safety and health of the users and therefore they must carefully read, understand and apply the indications/procedures.

The compliance with these indications enables the safe use of the machine, as well as the implementation of appropriate interventions. As indicated above, the declaration of conformity and all use and maintenance technical manuals concerning the LDPU will accompany it in the event it is sold to other users.

This documentation must be kept with care until the final demolition of the same LDPU and must be made available to the personnel appointed to operate.

It is good practice not to damage the manual and keep it properly, do not tear pages, dirty them or get them greasy, never expose them to sources of heat and always maintain the proper layout. This documentation and relative annexes must also be made available to the personnel authorised to operate on the LDPU, in such a way that it can be consulted easily, to clear any doubts about its safe operation and/or about the execution of use and maintenance procedures.

What is contained in the technical manuals reflects the state of the art at the time of construction of the machine in question. The technical manuals cannot be considered inadequate, as a result of technological improvements of the LDPU.

The technical documentation and relative annexes are completely confidential: reserves all rights related to this use and maintenance manual and with the object presented therein. The receiving party recognises these rights to O.M.A.C. s.r.l., in the person of its legal representative, Mrs Paola ZAVARONI, and undertakes, in the absence of an explicit written consent, not to make it accessible to others, either in whole or in part and, not to use it outside the purpose for which it was created. Violators will be prosecuted according to law.

SYMBOLS USED

Important information, regarding the technical reliability and safe use, are highlighted in this manual in the following way (these symbols always precede the text they refer to):



DANGER

The DANGER symbol draws attention to a procedure, practice or similar measure which, if not performed correctly, can result in injury. Do not proceed beyond a DANGER symbol until you have fully understood and satisfied the conditions specified.



WARNING

The WARNING symbol draws attention to an operating procedure, practice or other similar measure that is potentially dangerous, which may involve risk of serious injury, if the instructions are not followed scrupulously.



ATTENTION

The ATTENTION symbol draws attention to an operating procedure, practice or other similar measure, which if not correctly performed or observed, can damage or completely destroy the product. Do not proceed beyond an ATTENTION symbol until you have fully understood and satisfied the conditions specified.



NOTE

Refers to technical aspects for which the user of the equipment must pay particular attention.

KEEPING THE MANUAL

The technical manuals relating to the LDPU is part of the same unit; therefore all the above mentioned technical documentation must accompany this machine even if it is sold.



WARNING

For the proper management of safety during use and maintenance of the LDPU, all the technical documentation must accompany it even if it is sold.



DANGER

The technical manuals contain the information / procedures concerning the use and management of safe maintenance of the LDPU, it must be kept in the vicinity of the place in which the machine operates, to which this documentation refers, in a place easily accessible by the operator responsible for its operation. The operator responsible for its operation and the maintenance engineer must be able to find and consult this documentation at all times.



DANGER

All the technical documentation that refers to the LDPU must be kept in an easily accessible place so that it can be consulted quickly. In addition, the personnel responsible for its use and maintenance must be informed where this documentation is kept.

LABELS APPLIED

Throughout the LDPU there are nameplates of the various components of the same unit.

The nameplate applied on the left side of the "B Series lobe displacement pump unit" (left side of the pump looking at the rotors) carries the LDPU serial number (the serial number starts with the letter "L" and is followed by six numbers), to which the item code of the LDPU is uniquely associated to. The coding rule of the LDPU item code is explained in section 1.2.2.

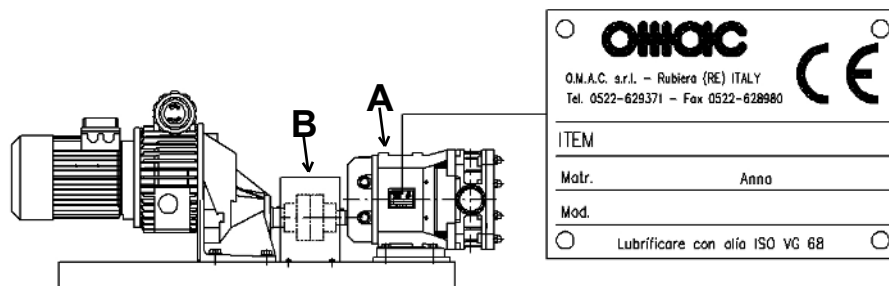

On the surfaces of the various components of the LDPU, there are plates with the prohibition to operate the LDPU dry (plate A), placed on the bearings box of the "B Series lobe displacement pump unit", and the plate warns the operator of the presence of mobile parts under the butt strap (plate B). In the event of LDPU's predisposed for pumping fluids at temperatures above 50°C, there is a signal placed on the same pump that warns the operators of the presence of high temperature surfaces, as shown in figure C:

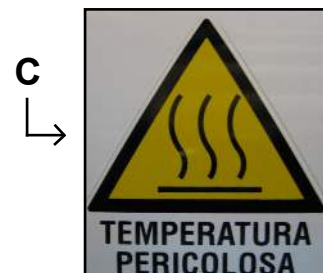
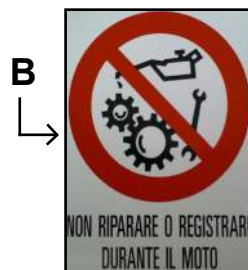

NOTE

Please note that the markings / labels present along the LDPU cannot be removed or altered for any reason.



WARNING

It is forbidden to use any O.M.A.C. item when it is without the nameplate. Should the item be without its nameplate it is compulsory for the customer to contact the O.M.A.C. Technical Office that will see to identify the item and re-issue the nameplate.

TERMS AND DEFINITIONS

OMM: Operation and Maintenance Manual.

LDPU: B Series Lobe displacement pump unit.

DANGEROUS AREAS: any area inside and/or in proximity of a machine in which the presence of an exposed person constitutes a risk for the safety and health of this person.

EXPOSED PERSON: any person who finds himself entirely or in part in a dangerous area.

MACHINE: together of parts as defined by Article 2 of Directive 2006/42/EC of the European Parliament and the Council of 17 May, 2006

MANUFACTURER: O.M.A.C. s.r.l

CUSTOMER: Physical or legal person on whose behalf the machine is built, upon prior written acceptance of an order confirmation.

CHAPTER 1: MACHINE AND PUMPED FLUID SPECIFICATIONS

1.1 Envisioned duration

Given the quality level of the materials and construction technologies used, if you strictly follow the instructions in this OMM (paying particular attention to chapters 3, 4 and 5, relating, respectively, to the installation, use and maintenance of the LDPU), the expected duration of such subject matter is estimated to be 12 months from date of installation.

Please note that, during its expected life-span, the LDPU must not be assembled and/or disassembled by unauthorised personnel and furthermore the instructions contained in this UMM must be followed scrupulously.

1.2 Technical description of the machine

Below there is a brief description of the LDPU, as well as a functional illustrational of the B series LDPU, in order to more easily identify the main construction details, mentioned in the description of use and maintenance of this document.

The LDPU is made up of 3 macro-components:

- 1) control unit (gear motor, speed controller, hydraulic motor, electric panel, etc.);
- 2) mechanical transmission device (flexible transmission coupling);
- 3) B Series LDPU;

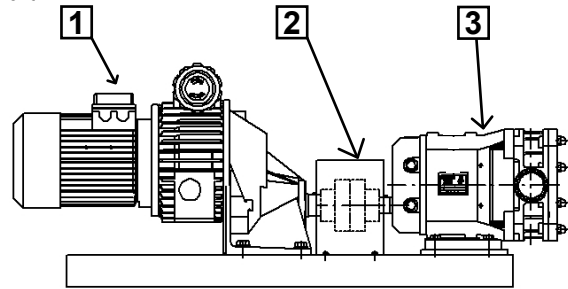

The B Series LDPU, identified with number 3) is made up as follows:

A = Rotorcase cover	M = Drive shaft
B = Lock nut	N = Fixed gear
C = Rotor	O = Oil level cap
D = Seal	P = Adjustable gear
E = Balancing ring	R = Driven shaft
F = Bearing retainer ring	S = Bearing housing
G = Front Bearing	T = Foot
H = Rear bearing	U = Rotorcase
K = Oil vent cap	V = Seal protection
L = Rear cover	

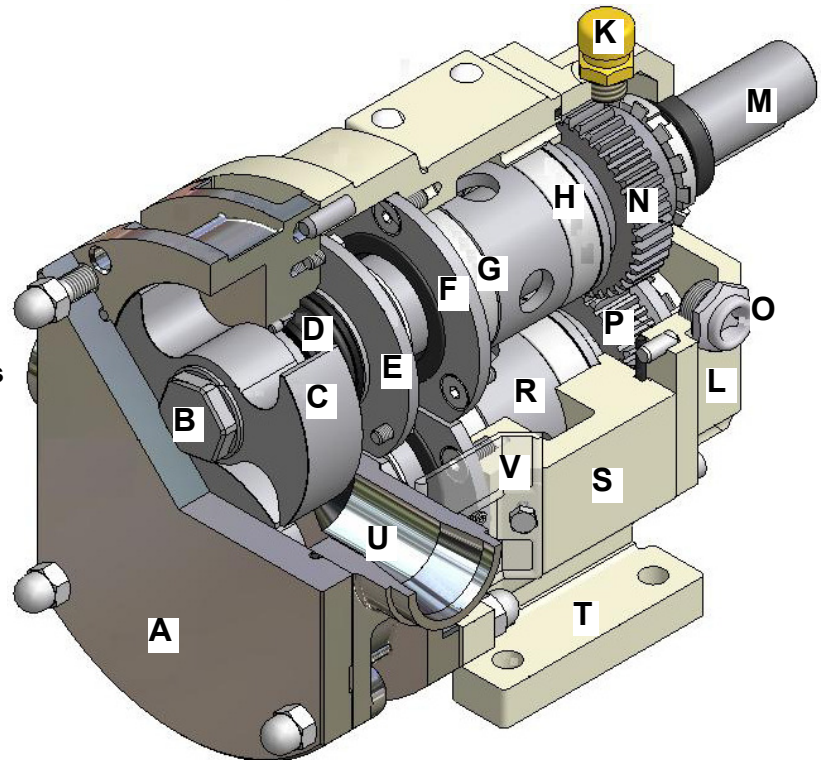

1.2.1 Operation principle of the B Series LDPU.

The LDPU, whose functional element is the B Series lobe positive displacement pump, is equipped with a control unit that, depending on the version, can be fitted with a gear motor, an electric motor, a pneumatic motor or a hydraulic motor, with or without electric panel.

The capacity adjustment is achieved by increasing or decreasing the number of revolutions of the B series lobe positive displacement pump, intervening directly on the revolutions output of the motor or acting on the actuators on the control panel (inverter), if fitted.

The LDPU is reversible: full performance can be achieved in both rotation directions of the pump rotors (section 1.3.5 of chapter 1 lists the types of rotors used).

The pumping action of the B series lobe displacement pump is achieved thanks to the counter-rotation of two rotors (letter "C" indicated in the figure in section 1.2, indicating one of the two rotors), housed inside the pumping chamber (letter "U" indicated in the figure in section 1.2 or see figure below). The rotors are assembled on rotating shafts supported by bearings (letters "G" and "H" shown in the figure in section 1.2), which are housed in the external gearbox (letter "S" shown in the figure in section 1.2). Via a couple of sprocket wheels (letters "N" and "P" indicated in the figure in section 1.2) one transfers motion from a drive shaft (letter "M" indicated in the figure in section 1.2) to a driven shaft (letter "R" indicated in the figure in section 1.2). The synchronism of the rotors is such that they rotate without coming into contact with each other: in these conditions "the rotors are in time".

When the lobes of the rotors move away from each other, the volume between them increases, creating a decrease in pressure near the suction outlet: this enables a certain volume of fluid to enter (value of fluid transported identified in the table in section 1.3.1, in the "theoretical capacity" column, depending on the pump model size) into the rotorcase. The fluid is transported along the internal of the pumping chamber, from the suction inlet to the discharge outlet of the rotorcase.

When the volume of fluid, trapped between the lobes and the external perimeter of the pumping chamber, reaches in proximity of the discharge outlet, the counter-rotation of the two rotors creates a sudden decrease of available volume and a consequent increase in pressure that pushes the fluid out of the rotorcase, by channelling it into the plant where the LDPU is installed.

FRONTAL VIEW OF THE PUMP CHAMBER

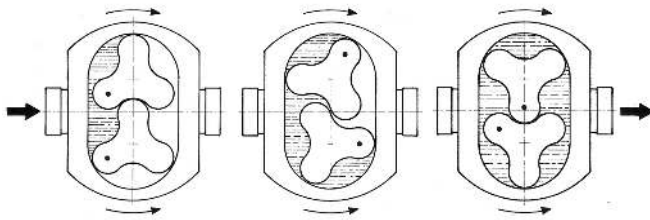

REAR VIEW OF THE PUMP SHAFT

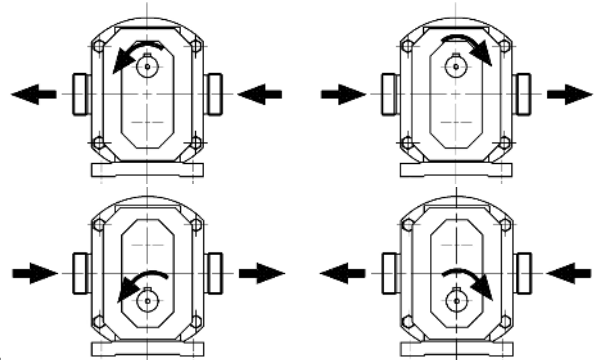

WARNING

If the control unit does not comply with the rotation direction indicated in the figure, the mechanical functionality of the LDPU is not compromised, but will not supply any delivery capacity. Failure to comply with the proper connection to the unit (suction inlet connected to the suction piping and delivery outlet connected to the unit delivery pipe) will cause improper installation of the LDPU by the customer.

1.2.2 B Series lobe positive displacement pump coding

The LDPU is identified by an item code, represented by a string of 18 alphanumeric characters that starts with "K" (the item code is detectable on the first line of the technical sheet of which there is an example in section 1.3) divided into the following structure:

K	1	1	2	3	4	5	6	7	7	7	8	8	9	V	V	V	V
---	---	---	---	---	---	---	---	---	---	---	---	---	---	---	---	---	---

Fields 1-1: pump series = "BO"

Field 2: pump size

A = 100; **B** = 105; **C** = 110; **D** = 115; **E** = 215; **F** = 220; **G** = 325; **H** = 330; **L** = 390; **M** = 430; **N** = 440; **P** = 470; **Q** = 490; **R** = 550; **T** = 660; **U** = 680;

Field 3: seal type

0 = UM type - S1 type - HN Elring type;

1 = Teflon packing;

2 = Teflon packing + liquid barrier;

3 = Single Mechanical Stainless Steel/Carbon;

4 = Single Mechanical Tungsten carbid/Carbon;

5 = Single Mechanical Tungsten carbid/Tungsten carbid;

6 = Single Mechanical Ceramic/Carbon;

7 = Single Mechanical Ceramic/Rulon;

8 = Single Mechanical Silicon carbid/Silicon carbid;

9 = Single Mechanical Tungsten carbid/Silicon carbid;

A = Single Mechanical Silicon carbid/Carbon;

B = Opened frontal lip;

C = Frontal o-ring;

D = Closed frontal lip;

M = Double lip 2HN in PTFE;

N = Single lip HN in PTFE;

P = Frontal lip in PTFE;

Q = Single lip HN modified (heat-welded);

R = Double lip 2HN modified (heat-welded);

Field 4: suction-discharge connections type

0 = GAS-BSP;

1 = flanged PN16 UNI EN 1092-1 – DIN2576;

2 = DIN 11851;

3 = SMS;

4 = RJT (BS);

5 = IDF-ISS;

6 = TRI-CLAMP;

7 = GAS;

8 = wine fitting;

A = Aseptic O.M.A.C.;

B = DIN 11864/1a;

C = DIN 11864/2a;

D = DIN 11864/3a;

E = DIN 11864/1b;

F = DIN 11864/2b;

G = DIN 11864/3b;

H = flanged PN40 UNI 6084-67/DIN 2501;

J = flanged ASME 150lb;

K = flanged IDF;

L = smooth for welding;

M = DS 722;

N = DIN 11851 (male);

P = MACON;

Q = flanged 5044/DIN 11850;

R = ISO KF CLAMP;

Field 5: tipo di rotori:

0 = Trilobe	Stainless Steel	ST;	B = Dual Wing	Stainless Steel	ST
1 = Trilobe/Gear	Stainless Steel	SM;	C = Dual Wing	Stainless Steel	SM
2 = Bilobe	Stainless Steel	ST;	E = Quadrilobe	Stainless Steel	SM
3 = Bilobe	Stainless Steel	SM;	F = Trilobe	Stainless Steel	SM;
4 = Trilobe	Stainless Steel	ST;	L = Trilobe/Gear	CY5SnBIM (antiseizure)	SM;
5 = Dual Wing	CY5SnBIM(antiseizure)	ST;	M = Dual Wing	CY5SnBIM (antiseizure)	SM;
6 = Bilobe	Stainless Steel	ST;	N = Trilobe	CY5SnBIM (antiseizure)	PR;
7 = Trilobe/Gear	CY5SnBIM (antiseizure)	ST;	P = Dual Wing	CY5SnBIM (antiseizure)	PR;
8 = Gear	Stainless Steel	ST;	Q = Gear	CY5SnBIM (antiseizure)	ST ultrareduced;
9 = Quadrilobe	Stainless Steel	ST;	R = Gear	CY5SnBIM (antiseizure)	ST reduced;
A = Bilobo	CY5SnBIM(antiseizure)	ST;			

(ST= standard rotor clearance; SM = increased rotor clearance; PR = exact rotor clearance)

Field 6: cover type

- 0 = standard;
 1 = with mechanical safety valve;
 2 = heated;
 3 = with pneumatic safety valve;
 4 = with wetted o-ring;
 5 = for built in locking nut;
 6 = for ultrareduced pump version;
 7 = for built in locking nut and heated;

- 8 = with drainage;
 A= aseptic;
 B = with mechanical safety valve and drainage;

Fields 7-7-7: pump single optionals

- A = aseptic pump;
 B = pump o-ring in N.B.R. (Buna);
 C = flushing for single mechanical seal in F.K.M. (°Viton);
 D = duplex shafts;
 E = PACD treatment;
 F = pump o-ring in kaflon 72B™;
 G = inner polishing surface Ra<0.8µ;
 H = high pressure pump;
 J = pump in titanium;
 K = kolsterizing treatment ;
 L = rectangular suction connection;
 M = pump in monel;
 N = niproly treatment;
 P = pump o-ring in teflon;
 R = heated pumping case;
 S = poliuretanic lip seal;
 T = hydraulic flange pump;
 U = pump o-ring in E.P.D.M.;
 V = pump o-ring in F.K.M. °VITON;
 W = pump o-ring in Kalrez Spectrum6375;

- X = Atex pump certified;
 Y = pump in hastelloy;
 Z = pump in hastelloy-titanium;
 1 = cheniflon treatment;
 2 = bearing housing S.S.Aisi 304;
 3 = pump o-rings 3-A certified;
 6 = nichel-plated cast iron bearing housing;
 7 = with feet for vertical connections disposition;
 9 = internal mechanical seals;
 0 = no options;

Fields 8-8: pump group optionals

- C1 = flushing for single mechanical seal in NBR;
 C2 = flushing for single mechanical seal in EPDM;
 C3 = flushing for single mechanical seal in PTFE;
 C4 = flushing for single mechanical seal in FKM;
 GG = inner polishing surface Ra<0.6µ;
 Q3 = secondary mechanical seal in S.S. Aisi 316 L/Carbon;
 Q4 = secondary mechanical seal in Tungsten carbid/Carbon;
 Q5 = secondary mechanical seal in Tungsten carbid/Carburo di Tungsteno;
 Q6 = secondary mechanical seal in Ceramic/Carbon;
 Q7 = secondary mechanical seal in Ceramic/Rulon;
 Q8 = secondary mechanical seal in Silicon carbid/Silicon carbid;
 QA = secondary mechanical seal in Silicon carbid/Carbon;
 11 = connections modified diameters suction/discharge to DN20 (3/4");
 12 = connections modified diameters suction/discharge to DN25 (1");
 13 = connections modified diameters suction/discharge to DN32 (1" 1/4);
 14 = connections modified diameters suction/discharge to DN40 (DN38) (1"1/2);
 15 = connections modified diameters suction/discharge to DN50 (DN51) (2");
 16 = connections modified diameters suction/discharge to DN65 (DN63) (2"1/2);
 17 = connections modified diameters suction/discharge to DN80 (DN73) (3");
 18 = connections modified diameters suction/discharge to DN100 (DN101) (4");
 19 = connections modified diameters suction/discharge to DN125 (5");
 21 = connections modified diameters suction/discharge to DN150 (6");
 22 = connections modified diameters suction/discharge to DN200 (8");
 23 = suction connections diameters DN125 / discharge connections diameters DN100;
 24 = flanged suction connection PN16 UNI2278 / flanged discharge connection DIN11851;
 28 = bearing housing S.S.Aisi 304 elettropolished;
 29 = External polishing of bearing housing and pumping case

Field 9: seal model

- 0 = other type of seal (no mechanical);
 3 = Fluiten KL2A sliding face reduced;
 7 = Roten U7K seal;
 1 = Internal seal;
 4 = Sealtek 556/S seal;
 2 = Fluiten KL2A seal;
 5 = Burgmann C5E seal;

Fields V-V-V-V: progressive versioning number

Digital counter that versions the item code according to the type of accessories and type of LDPU and according to the type of associated control unit.

1.3 Technical features

The technical data of the LDPU is listed in the "technical sheet", of which there is an example below. The technical sheet is delivered to the Customer together with the LDPU, in original and edited without the possibility of manual corrections.



ATTENTION

The technical sheet must not have any manual corrections or deletions.

The technical sheet lists the item code, which identifies the LDPU, the serial number (detectable on the riveted nameplate on the bearings box of the B series lobe displacement pump), its functional features (processed fluid and its properties, pump speed, volumetric capacity, differential pressure,..) and the features of the B Series lobe displacement pump components. The technical sheet below lists the technical data of the control unit (motorisation, gear motor, speed controller,..), of the flexible mechanical transmission coupling, that connects the "B Series lobe displacement pump" to the motorisation, and the type of support on which the LDPU is fitted.

O.M.A.C. S.r.l.		DATA SHEET			Mod. 13 04 del 31/07/2008			
Via G. Falcone 8 42048 RUBIERA (RE) ITALY Tel/Ph. 0039-0522-62.93.71 / 62.99.23 Fax 0039-0522-62.89.80 http://www.omacpompe.com E-mail: info@omacpompe.com		Codice Cliente 000000000	Tipo A	Numero 0000000	Data / /			
Nostro Rifornimento		Vostro Rifornimento						
Mittente/Ordine		Destinatario/Mezza		Destinatario/Ordine				
Riga	Descrizione	U.M.	Quantità	Q.tà Totale	Sconti	Importo	I.V.A.	Consegna
	KBO00000000000000000000000000 PUMP	NR	1 DI	1,00				
PRODUCT INFO		Serial number L000000						
PUMP PERFORMANCES		MEDIA DESCRIPTION VISCOSITY TEMPERATURE FLOW-RATE PRESSION PUMP SPEED TORQUE ABSORBED POWER						
TECHNICAL FEATURES		MODEL CERTIFICATION ROTOS SEAL TYPE SEAL GASKETS SUCTION - DISCHARGE CONNECTIONS Ø SUCTION - Ø DISCHARGE CONNECTIONS DISPOSITION PUMP COVER PUMP GASKETS SHAFT POSITION BEARING HOUSING OIL NAME PLATE						
SUPPORT FEATURES		TYPE SIZE						
JOINT FEATURES		TYPE CARTER HOLE (PUMP) HOLE (MOTORIZATION)						
PUMP ANCILLARIES DOCUMENTS								
<small> Informativa d.lgs. 30.6.2003 n. 196 TU Privacy I suoi dati personali saranno trattati, nel rispetto delle idonee misure di sicurezza, per invio di comunicazioni commerciali, potrà esercitare i diritti previsti dalla legge e nelle modalità ivi completate. Titolare del trattamento dati è O.M.A.C. S.r.l., sede legale: 42048 Rubiera in Via G.Falcone, 8. Per comunicazioni info@omacpompe.com. Per ulteriori informazioni www.omacpompe.com </small>								

The exploded view below highlights the position numbers of some components which will be discussed later in this chapter.

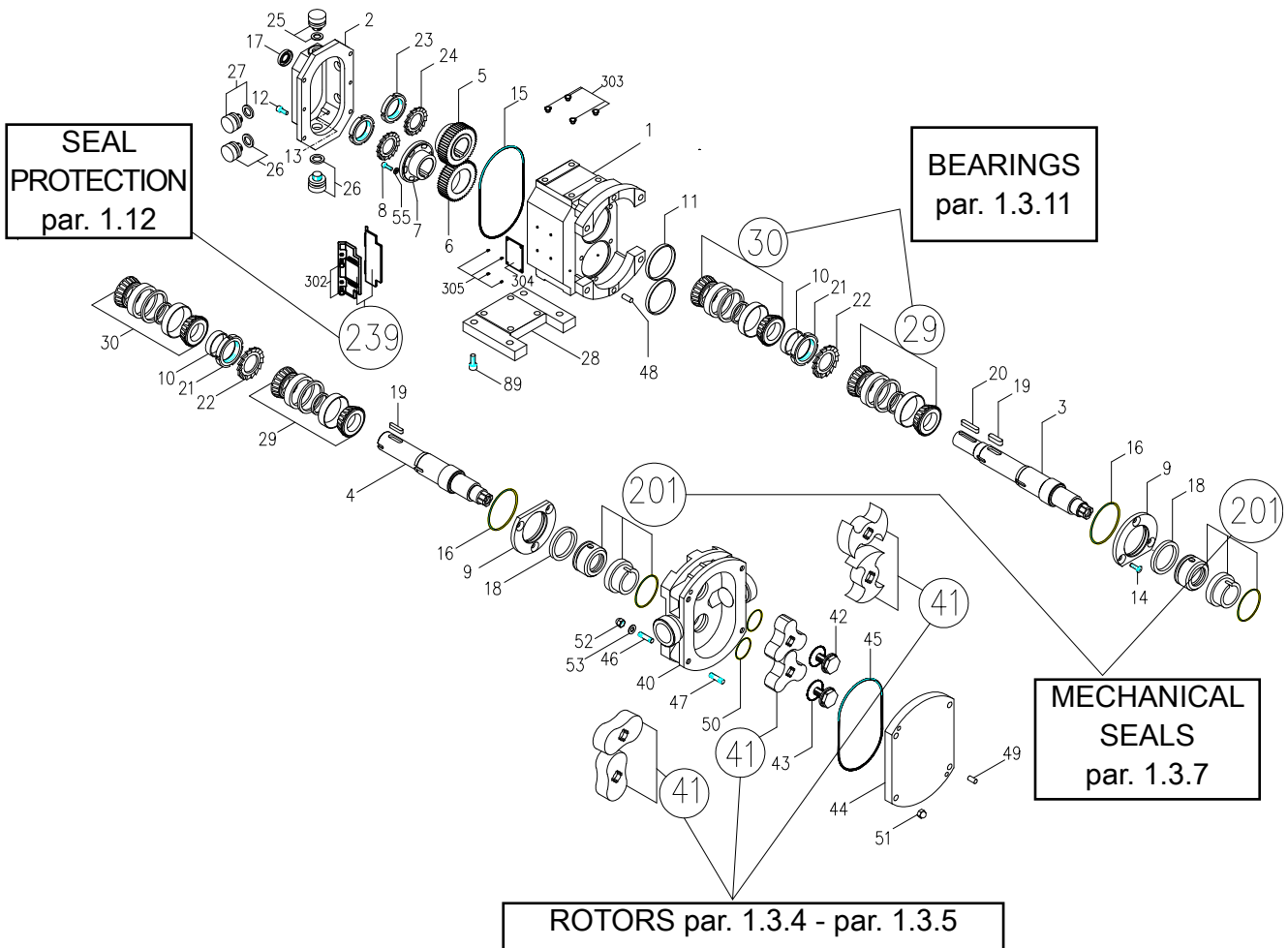

1.3.1 Technical features of the B Series lobe positive displacement pump

The table below shows the nominal features of the various dimensions of the B series lobe displacement pump, inserted in the LDPU. The data that make up the table refer to the pump model, the capacity that each pump model (B100, B105, B110...) elaborates every 100 revolutions, the maximum operation speed of each pump size, the differential operating pressure, expressed in bar, and the standard dimensions of the opening couplings, expressed in millimetres and inches.

PUMP MODEL	THEORETIC CAPACITY	MAXIMUM SPEED	MAXIMUM POWER	MAXIMUM OPERATING PRESURE (bar)					STANDARD CONNECTION	
				rotor clearances ST (standard) with shafts		rotor clearances SM (increased) with shafts		High pressure Duplex + Acteon	DN	Inches
				S.S. AISI 316 L	DUPLEX	S.S. AISI 316 L	DUPLEX			
B100	3	1400	1.5	7	10	-	-	-	25	1"
B105	7	1000	4	10	13	15	18	-	40	1" 1/2
B110	12	1000	4	10	13	15	18	20	40	1" 1/2
B115	18	1000	5.5	7	10	12	15	-	40	1" 1/2
B215	23	950	7.5	10	13	15	18	20	40	1" 1/2
B220	34	950	7.5	7	10	12	15	-	50	2"
B325	55	720	18.5	10	13	15	18	20	65	2" 1/2
B330	70	720	18.5	7	10	12	15	-	80	3"
B390	90	720	18.5	5	7	10	12	-	80	3"
B430	116	600	30	10	13	15	18	20	80	3"
B440	155	600	30	7	10	12	15	-	100	4"
B470	240	500	45	10	13	15	18	20	100	4"
B490	330	500	45	7	10	12	15	-	100	4"
B550	400	500	45	5	-	7	-	-	125	5"
B660	700	500	75	7	-	-	-	-	150	6"
B680	1050	500	75	4	-	-	-	-	200	8"

1.3.2 Variation of maximum operating pressure according to temperature

The table below lists the maximum differential pressure values, processed by the B series lobe displacement pump, inserted in the LDPU, according to the size of the pump (from B100 to B680), according to the temperature of the processed fluid (from 0-70°C, 90°C, 110°C,...) and according to the type of rotors fitted: with clearances between rotor and ST standard pumping chamber, SM increased clearances or clearances for HP high pressures.

The values of these clearances between rotors and pumping chamber are shown in the section 1.3.4.

TEMPERATURE °C	ROTOR TYPE	B SERIES MODEL PUMP															
		B100	B105	B110	B115	B215	B220	B325	B330	B390	B430	B440	B470	B490	B550	B660	B680
0°C a 70°C	ST	7	10	10	7	10	7	10	7	5	10	7	10	7	5	7	5
	SM	-	15	15	12	15	12	15	12	10	15	12	15	12	7	10	7
	HP	-	-	20	-	20	-	20	-	-	20	-	20	-	-	-	-
90°C	ST	5.2	8.8	8.9	6.5	9	6.5	9.1	6.5	4.5	9.1	6.4	9.1	6.3	4.4	6.4	4.4
	SM	-	15	15	12	15	12	15	12	10	15	12	15	12	7	10	7
	HP	-	-	18.8	-	18.9	-	19	-	-	19	-	19	-	-	-	-
110°C	ST	4	7.6	7.8	5.7	8	5.9	8.2	6	-	8.4	5.8	8.4	5.9	5.8	5.8	3.9
	SM	-	15	15	12	15	21	15	12	-	15	12	15	12	10	10	7
	HP	-	-	17.6	-	17.7	-	18	-	-	18	-	18	-	-	-	-
120°C	ST	3.4	7	7.3	5.5	7.5	5.6	7.8	5.7	-	7.9	5.5	7.8	5.4	3.7	5.5	3.7
	SM	-	14	14.6	11.7	14.5	11.7	14.5	11.7	-	14.6	11.7	14.6	11.6	6.8	9.5	6.8
	HP	-	-	17.1	-	17.2	-	17.6	-	-	17.5	-	17.5	-	-	-	-
140°C	ST	2.2	6	6.3	5.1	6.5	5	7	5.2	-	7.2	4.9	7.2	4.9	3.2	4.9	3.2
	SM	-	13	13.6	11.3	13.6	11.1	13.8	11.2	-	13.7	11.1	13.7	11.1	6.4	8.6	6.4
	HP	-	-	16.1	-	16.3	-	16.8	-	-	16.6	-	16.6	-	2.6	-	-
160°C	ST	-	-	5.3	5	5.5	4.4	6.1	4.6	-	6.4	4.3	6.4	4.2	2.6	4.3	2.6
	SM	-	-	12.7	10.8	12.7	10.5	12.9	10.7	-	12.9	10.4	12.7	10.4	6	7.8	6
	HP	-	-	15.1	-	15.3	-	15.8	-	-	15.8	-	15.6	-	-	-	-
180°C	ST	-	-	4.3	4.2	4.5	3.9	5.2	4.1	-	5.5	3.6	5.4	3.6	2	3.6	2
	SM	-	-	12.1	9.9	11.8	10.5	12.1	10.1	-	12	9.7	12	9.7	5.5	6.9	5.5
	HP	-	-	14.1	-	14.3	-	14.9	-	-	14.9	-	14.6	-	-	-	-

1.3.3 Motorization and transmission coupling technical features

The mechanical features of the flexible transmission coupling and the performance features of the control unit (electrical, pneumatic, hydraulic), according to the type of operation chosen by the customer, are shown in the respective use and maintenance manuals; documents that are supplied with the LDPU.

1.3.4 Rotors clearances

This section lists the nominal clearances (ST standard, SM increased), that are recorded between rotors and walls of the pumping chamber according to the material (AISI 316 L, anti-friction alloy CY5SnBIM). The figure, on the next page, represents a rotor section, fitted in the pumping chamber, with indication of clearances, identified by letters A,B,C,D. The table below shows the entity of these clearances. The "S" value represents the protrusion of the shaft compared to the wall of the pumping chamber.

	ROTORS S.S. AISI 316 L				ROTORS S.S. AISI 316 L				ROTORS ANTISEIZURE				SHAFT
	ST VERSION				SM VERSION				CY5SnBIM				PROTRUSION
	A	B	C	D	A	B	C	D	A	B	C	D	S
B100	0.12	0.12	0.15	0.2	0.15	0.15	0.2	0.2	0.07	0.08	0.19	0.15	0.12
B105	0.12	0.14	0.15	0.25	0.17	0.19	0.2	0.3	0.05	0.05	0.13	0.15	0.12
B110	0.14	0.14	0.15	0.3	0.19	0.19	0.23	0.3	0.08	0.07	0.15	0.2	0.14
B115	0.14	0.14	0.18	0.3	0.19	0.19	0.22	0.3	0.07	0.08	0.2	0.2	0.14
B215	0.15	0.15	0.18	0.3	0.22	0.23	0.3	0.3	0.08	0.07	0.18	0.2	0.15
B220	0.15	0.17	0.23	0.3	0.25	0.25	0.32	0.3	0.08	0.07	0.2	0.2	0.15
B325	0.17	0.17	0.2	0.35	0.25	0.25	0.32	0.35	0.08	0.08	0.2	0.2	0.17
B330	0.17	0.19	0.23	0.35	0.27	0.28	0.32	0.35	0.09	0.08	0.23	0.2	0.17
B390	0.17	0.19	0.23	0.35	0.27	0.28	0.32	0.35	0.09	0.08	0.23	0.2	0.17
B430	0.18	0.18	0.22	0.35	0.27	0.27	0.32	0.35	0.09	0.08	0.23	0.2	0.18
B440	0.18	0.18	0.22	0.35	0.27	0.27	0.32	0.35	0.1	0.1	0.25	0.2	0.18
B470	0.2	0.2	0.27	0.35	0.32	0.32	0.35	0.35	0.09	0.09	0.25	0.2	0.2
B490	0.23	0.23	0.3	0.35	0.35	0.35	0.35	0.45	0.09	0.09	0.25	0.2	0.23
B550	0.22	0.22	0.3	0.4	0.32	0.32	0.43	0.4	0.15	0.15	0.35	0.25	0.22
B660	0.27	0.27	0.35	0.5	0.37	0.37	0.5	0.5	-	-	-	-	0.27
B680	0.3	0.35	0.35	0.5	0.37	0.37	0.5	0.5	-	-	-	-	0.27

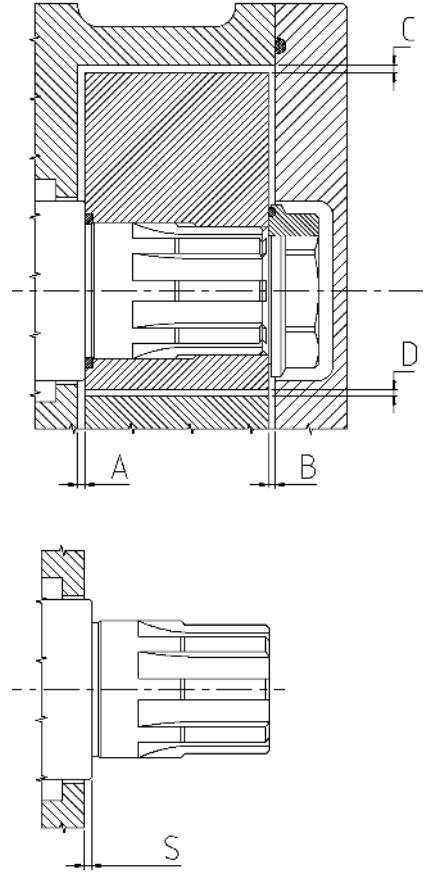

Dimensions expressed in mm - Tolerances 0/+0.03

1.3.5 Rotors geometry

The table below shows the types of rotors, per type of construction material and geometric shape, available for every size of "B series lobe pump".

ROTOR TYPE	B SERIES MODEL PUMP															
	B100	B105	B110	B115	B215	B220	B325	B330	B390	B430	B440	B470	B490	B550	B660	B680
GEAR S.S. AISI 316 L	•	•														
GEAR CY5SnBIM	•	•														
DUAL-WING S.S. AISI 316 L						•										
DUAL-WING CY5SnBIM	•	•	•	•	•	•	•	•	•	•	•	•	•	•	•	•
TRILOBE S.S. AISI 316 L			•	•	•	•	•	•	•	•	•	•	•	•	•	•
TRILOBE CY5SnBIM			•	•	•	•	•	•		•	•					
RUBBER COATED TRILOBE (*)	•	•	•	•	•	•								•	•	
BILOBE S.S. AISI 316 L	•		•	•	•	•	•	•	•	•	•	•	•	•		
BILOBE CY5SnBIM	•		•	•	•	•	•	•		•	•					
RUBBER COATED BILOBE						•		•		•	•			•		

(*) Penta-lobe for B100 and B105

1.3.6 Tightening torque

This table shows the tightening torque values, to be used as reference during all assembly and disassembly operations of pump components, in one or more parts. The values mentioned in the table below relate to gear adjustment, rotor blocking, pumping body blocking, front cover blocking, bearing ring blocking and gear ring blocking.

PUMP MODEL	GEAR ADJUSTMENT (pos.8, pag.15)			ROTOR LOCKING (pos.42, pag.15)			PUMPING CASE LOCKING (pos.52, pag.15)			FRONT COVER LOCKING (pos.51, pag.15)		
	Thread d x pitch	Key type / Size [mm]	TORQUE [Nm]	Thread d x pitch	Key type / Size [mm]	TORQUE [Nm]	Thread d x pitch	Key type / Size [mm]	TORQUE [Nm]	Thread d x pitch	Key type / Size [mm]	TORQUE [Nm]
B100	M4X0.7	A/7	3	M8X1	A/17	25	M6X1	A/10	10	M6X1	A/10	10
B105 B110 B115	M5X0.8	B/4	5	M12X1	A/27	85	M8X1.25	A/13	30	M8X1.25	A/13	30
B215 B220	M6X1	B/5	10	M14X1.5	A/30	190	M10X1.5	A/17	50	M10X1.5	A/17	50
B325 B330 B390	M8X1.25	B/6	20	M20X1.5	A/38	305	M12X1.75	A/19	70	M10X1.5	A/17	50
B430 B440	M10X1.25	B/8	50	M24X2	A/46	480	M16X2	A/24	115	M12X1.75	A/19	70
B470 B490	M10X1.25	B/8	50	M24X2	A/46	480	M20X2.5	A/30	180	M14X2	A/22	95
B550	M12X1.75	A/19	70	M24X2	A/46	500	M14X2	A/22	115	M12X1.75	A/19	70
B660 B680	M16X2	A/24	170	M36X2	A/60	600	M14X2	A/22	115	M14X2	A/22	70

PUMP MODEL	BEARING RING NUT LOCKING (pos.21, pag.15)			GEAR RING NUT LOCKING (pos.42, pag.15)		
	Thread d x pitch	Key type / Size [mm]	TORQUE [Nm]	Thread d x pitch	Key type / Size [mm]	TORQUE [Nm]
B100	-	-	-	M20X1	HN4	50
B105 B110 B115	M30X1.5	HN6	90	M30X1.5	HN6	90
B215 B220	M40X1.5	HN8	105	M35X1.5	HN7	90
B325 B330 B390	M50X1.5	HN10	115	M40X1.5	HN8	105
B430 B440	M70X2	HN14	220	M60X2	HN12	145
B470 B490	M80X2	HN16	400	M70X2	HN14	220
B550	M70X2	HN14	220	M70X2	HN14	220
B660 B680	-	-	-	M100X2	HN20	600

The "A" type spanner - ref. "spanner type" column - is a polygonal spanner; the "B" type spanner - ref. "spanner type" column - is hexagonal (inbus or imbus).



NOTE

With regard to the tightening torque value of the elements that make up the LDPU, please refer to the use and maintenance manuals (flexible transmission coupling, motorisation).

1.3.7 Mechanical seals overall dimensions

Below there are the overall dimensions of the mechanical seals fitted on the B series lobe pump, according to the size of the pump and the position of the seal. The drawing below shows the references relative to the main dimensions of the mechanical seals, whose values, in mm, are shown in the table, according to the size of the pump.

	B100	B105 B110 B115	B215 B220	B325 B330 B390	B430 B440	B470 B490	B550	B660 B680
d1	20	30	35	50	65	80	65	100
d6	29	39	44	62	77	95	77	115
d7	35	45	50	70	85	105	85	125
L1	29.1	29.1	29.1	34.1	38.8	43.8	38.8	41.3
L2	44	44	44	50	55.5	59	55.5	85
L3	19.1	19.1	19.1	21.1	25.8	25.8	25.8	25.8
L4	10	10	10	13	13	18	13	15.5
L5	2	2	2	2.5	2.5	3	2.5	3
L6	5	5	5	6	6	7	6	7
L7	9	9	9	9	9	9	9	9

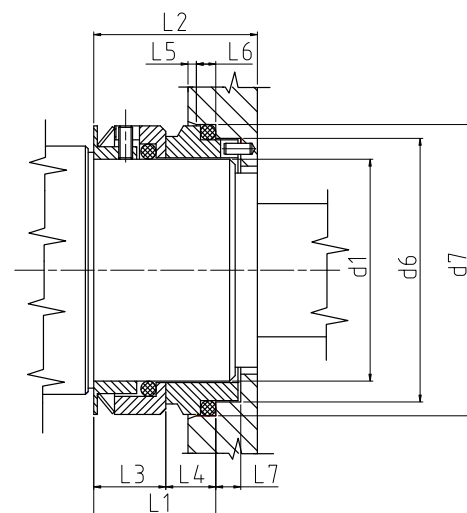

1.3.8 Weights and dimensions table of the B Series lobe positive displacement pump

The table below shows the dimensions of the B series lobe pump, with reference to its size and according to the type of connections it is equipped with. With regard to the dimensions of the LDPU, these vary according to the type of control unit supplied, therefore they must be expressly requested to the O.M.A.C. Technical Office.

PUMP WITH CONNECTIONS IN HORIZONTAL POSITION

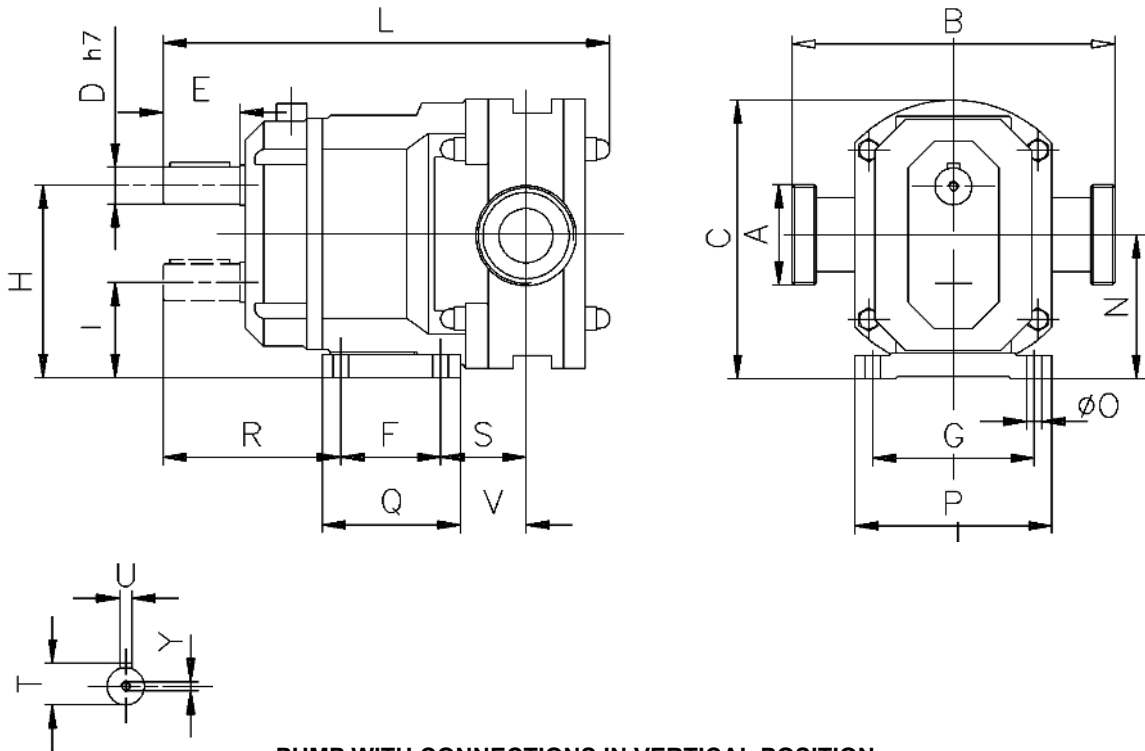

PUMP WITH CONNECTIONS IN VERTICAL POSITION

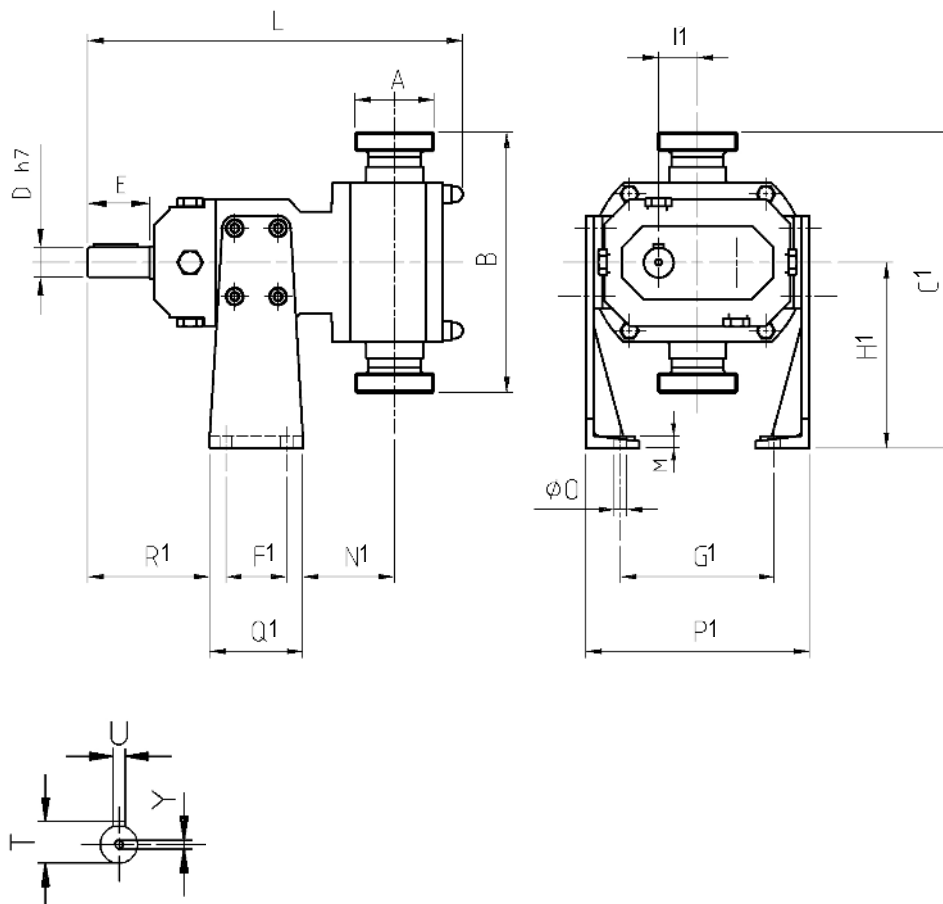

POSITION	MODEL PUMP																
	B100	B105	B110	B115	B215	B220	B325	B330	B390	B430	B440	B470	B490	B550	B660	B680	
C	115.5	181	181	181	235.5	235.5	270	270	270	367.5	367.5	442.5	442.5	515	690	690	
D	18	24	24	24	28	28	35	35	35	48	48	55	55	55	80	80	
E	43.5	50	50	50	55	55	65	65	65	85	85	110	110	110	140	140	
F	65	65	65	65	90	90	120	120	120	140	140	150	150	20	300	300	
F1	-	49	49	49	87	87	110	110	110	135	135	175	175	-	-	-	
G	105	105	105	105	125	125	140	140	140	190	190	250	250	300	300	400	
G1	-	124	124	124	166	166	192	192	192	270	270	320	320	-	-	-	
H	80	125	125	125	165	165	190	190	190	255	255	300	300	350	480	480	
H1	-	150	150	150	155	155	175	175	175	210	210	300	300	-	-	-	
I	-	62	62	62	90	90	100	100	100	130	130	160	160	178	250	250	
I1	-	31.5	31.5	31.5	37.5	37.5	45	45	45	62.5	62.5	70	70	-	-	-	
L	265	290.5	290.5	302.5	365.5	380.5	459	474	494	543.5	563.5	654	684	637	807	867	
N	58.6	93.5	93.5	93.5	127.5	127.5	145	145	145	192.5	192.5	230	230	264	365	365	
N1	-	62.5	62.5	74	81	90	107	116	136	119	126.5	118.5	148	-	-	-	
O	9	10	10	10	12	12	14	14	14	18	18	22	22	19	26	26	
P	125	128	128	128	152	152	174	174	174	235	235	300	300	350	460	460	
P1	-	180	180	180	240	240	272	272	272	360	360	430	430	-	-	-	
Q	92	90	90	90	130	130	170	170	170	195	195	255	255	250	360	360	
Q1	-	75	75	75	115	115	140	140	140	170	170	220	220	-	-	-	
R	110.5	115.5	115.5	115.5	136.5	136.5	167	167	167	206.5	206.5	255	255	227	283	283	
R1	110.5	98.5	98.5	98.5	108.5	108.5	134	134	134	165.5	165.5	210	210	-	-	-	
S	52	55.5	55.5	67	78	87	94	103	123	109	116.5	143.5	173	106.5	122	152	
T	20.5	27	27	27	31	31	38.5	38.5	38.5	52	52	60	60	60	85	88	
U	6	8	8	8	8	8	10	10	10	14	14	16	16	16	22	22	
V	49.5	42.5	42.5	54	52	61	62	71	91	76.5	84	63.5	93	81.5	92	122	
Y	-	M6	M6	M6	M8	M8	M10	M10	M10	M12	M12	M12	M12	M12	M16	M16	
Kg.	10.5	20	20	21	41	43	63	65	69	130	135	225	233	270	610	670	
GAS BSP	A	1"	1" 1/2	1"1/2	1"1/2	1"1/2	2"	2"1/2	3"	3"	3"	4"	4"	4"	-	-	-
	B	160	170	170	170	208	208	236	236	236	335	335	385	385	-	-	-
	C1	-	235	235	235	259	259	293	293	293	377.5	377.5	492.5	492.5	-	-	-
FLANGED UNI 1092 ex 2278 PN16	A	DN25	DN40	DN40	DN40	DN40	DN50	DN65	DN80	DN80	DN80	DN100	DN100	DN100	DN125	DN150	DN200
	B	165	186	186	186	224	228	256	256	256	355	355	405	405	566	680	670
	C1	-	243	243	243	267	269	303	303	303	387.5	387.5	502.5	502.5	-	-	-
DIN 11851	A	DN25	DN40	DN40	DN40	DN40	DN50	DN65	DN80	DN80	DN80	DN100	DN100	DN100	DN125	-	-
	B	160	210	210	210	248	248	296	296	296	395	395	445	445	632	-	-
	C1	-	255	255	255	279	279	323	323	323	407.5	407.5	522.5	522.5	-	-	-
SMS	A	DN25	DN38	DN38	DN38	DN38	DN51	DN63	DN76	DN76	DN76	DN101	DN101	DN101	-	-	-
	B	150	210	210	210	248	248	296	296	296	395	395	445	445	-	-	-
	C1	-	255	255	255	279	279	323	323	323	407.5	407.5	522.5	522.5	-	-	-
IDF-ISS	A	DN25	DN38	DN38	DN38	DN38	DN51	DN63	DN76	DN76	DN76	DN101	DN101	DN101	-	-	-
	B	153	210	210	210	248	248	296	276	276	375	378	428	428	-	-	-
	C1	-	255	255	255	279	279	323	323	323	397.5	399	514	514	-	-	-
RJT	A	DN25	DN38	DN38	DN38	DN38	DN51	DN63	DN76	DN76	DN76	DN101	DN101	DN101	-	-	-
	B	157	210	210	210	248	248	290	286	286	385	389	439	439	-	-	-
	C1	-	255	255	255	279	279	320	318	318	402.5	404.5	519.5	519.5	-	-	-
TRI CLAMP	A	1"	1"1/2	1"1/2	1"1/2	1"1/2	2"	2"1/2	3"	3"	3"	4"	4"	4"	-	-	-
	B	160	210	210	210	248	248	293	290	290	389	392	442	442	-	-	-
	C1	-	255	255	255	279	279	321.5	320	320	404.5	406	521	521	-	-	-

For other connections please contact the Technical Department Omac

1.3.9 Dimensions of pumping case connections, equipped with heating/cooling chamber and flushing seals.

At times the Customer may request, according to the production needs, to heat/cool the pumping chamber or to fit some flushed mechanical seals (for further information please refer to section 1.11). The dimensions of the heating / cooling fluid inlet and outlet holes of the pumping chamber and the dimensions of the flushing holes of the mechanical seals are shown in the following table and are divided per pump model.

Dimensions A, B and C are expressed in inches, dimensions D, E, F, G, L in millimetres.

POS.	DESCRIPTION	PUMP MODEL															
		B100	B105 B110	B115	B215	B220	B325	B330	B390	B430	B440	B470	B490	B550	B660	B680	
A	Seal flushing holes	-	1/8"	1/8"	1/8"	1/8"	1/8"	1/8"	1/8"	1/8"	1/8"	1/8"	1/8"	1/8"	1/4"	1/4"	
B	Rotor case heating fluid connections size	-	1/2"	1/2"	1/2"	1/2"	1/2"	1/2"	1/2"	1/2"	1/2"	3/4"	3/4"	3/4"	3/4"	3/4"	
C	End cover heating fluid connections size	1/8"	1/2"	1/2"	1/2"	1/2"	1/2"	1/2"	1/2"	1/2"	1/2"	3/4"	3/4"	3/4"	3/4"	3/4"	
D	Distance between end cover fluid connections	56	75	75	100	100	122	122	122	150	150	180	180	180	300	300	
E	Nut heigh	12	15	15	18	18	18	18	18	22	22	25	25	24	27	27	
F	End cover heating chamber thickness	17	20	20	20	20	20	20	20	18	18	23	23	23	30	30	
G	End cover heating chamber diameter	104	126	126	156	156	179	179	179	219	219	280	280	280	400	400	
L	Pump lenght	256	295.5	307.5	367.5	382.5	461	476	476	543.5	563.5	654	684	637	807	867	



ATTENTION

The drawing on the right shows the connection method of the seals flushing system, with indication of the flushing liquid circulation direction. Carefully read and understand the flushing operation methods described in section 5.7.4.

FLUSHING DISPOSABLE CIRCUIT

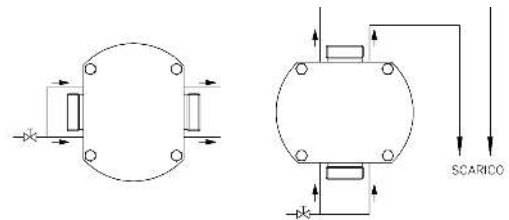

HEATING / COOLING PUMPING CASE AND FRONT COVER

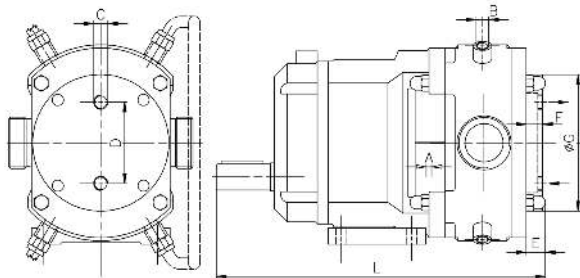

FLUSHING CIRCUIT WITH TANK

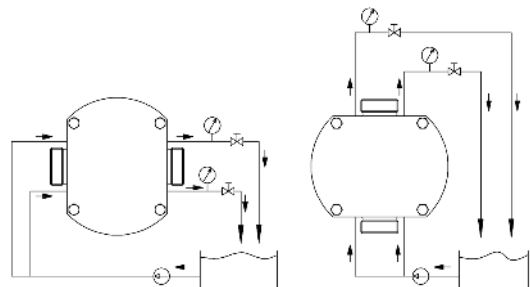

1.3.10 Suction inlet dimensions in "widened rectangular inlet port" version of the B Series lobe positive displacement pump

To facilitate handling of viscous fluids or fluids that contain a percentage of solids, O.M.A.C. s.r.l. has designed and made a B series lobe displacement pump with a widened rectangular suction inlet (see indication in the drawing below).

PUMP MOD.	POSITION									
	A	B	C	D	E	F	G	H	L	M
B115	40	22	18	90	70	42	23	19	61	120
B220	55	31	24	110	92	54	32	22	72	150
B330	75	37	38	146	133	65	32	33	93	176
B440	75	32.5	42.5	230	180	81	40.5	40.5	115	248
B490	107	67	40	230	180	107	69	38	143	256

For design requirements, this optional feature is available only on models B115, B220, B330, B440, B490. The figure below shows the position of the widened rectangular inlet on the pumping chamber, and the table shows, according to the model type, the dimensions of the inlet, as well as the dimensions of the B Series lobe displacement pump.

PUMP MOD.	POSITION									
	N	O	P	Q	R	S	T	U	V	Z
B115	67	M6	64	154	6	55	35	93.5	94	M8
B220	87	M8	78	210	15	67	67	127.5	114	M10
B330	103	M8	95	236	12.5	70	85	145	143.5	M12
B440	116.5	M10	122.5	320	12.5	100	100	192.5	161.5	M14
B490	173	M12	152.5	370	12.5	130	135	230	190.5	M20

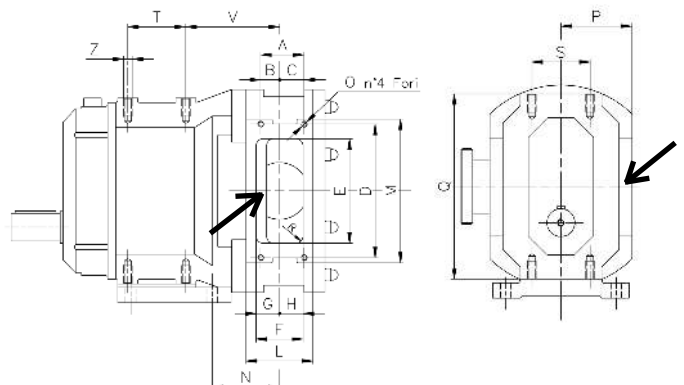

1.3.11 Bearings

The two tables to the side show, according to the pump size, the identity abbreviations of the bearings fitted on the transmission shafts of the B Series lobe displacement pump, inserted in the LDPU.

PUMP MODEL	PRE-ASSEMBLED BEARINGS	
	FRONT	REAR
B105 B110 B115	32006X	
B215 B220	32008X	32007X
B325 B330 B390	32010X	32008X
B430 B440	32014X	32012X
B470 B490	32016X	32014X

PUMP MODEL	ISO BEARINGS	
	FRONT	REAR
B100	TLA 3020 Z	NATB 5904
	LRT 253020	
B550	NJ 2216 E	3214
B660 B680	NJ 224 E	3220

The front bearing has position number 29, whilst the rear bearing has position number 30, with reference to the exploded view of page 5 in this chapter.

- The bearings of pump mod. B100 are ISO standard radial rollers type. The radial rear roller bearings combined with NATB 5904 oblique ball bearings, undergo an assembly adaptation to cancel the axial play.
- The bearings of pump mod. B5 - B6 are ISO standard cylindrical and oblique type with two rows of balls, commonly available on the market.
- The bearings of pump mod. B1 - B2 - B3 - B4 - B470 - B490 are made up of two metric bearings with a single row of conical rollers, by a spacer for the internal rings and by a spacer for the external rings. The assembly of the bearings is performed accurately by our technicians to ensure ideal rotation without play. For this reason, these bearings must be requested directly from O.M.A.C. s.r.l. that supplies them already pre-assembled with the right pre-load.
- The duration of the bearings varies significantly according to the varying of the working conditions (speed, pressure, absorbed power) and therefore one cannot define it beforehand.

1.3.12 Lubricants used and quantities

The three tables show the general features of lubricant oil that can be used to lubricate bearings and sprocket wheels.

Tables A and B show the type of oil to be used according to the temperature of the processed fluid (from -20°C to +90°C, and from +90°C to +150°C): table A only refers to lobe displacement pump models B100, B105, B110, B115, B215, B220, B325, B330, B390, B430, B440, B470, B490; table B only refers to lobe displacement pump models B550, B660, B680.

The lines of the table that refer to "BRAND" list a series of possible suppliers where the lubricant can be bought.

PUMP MODEL	BRAND	WORKING TEMPERATURE	
		from -20°C to +90°C (oil viscosity ISO VG 68)	from +90°C to +150°C (oil viscosity ISO VG 150)
B100 B105 B110 B115 B215 B220 B325 B330 B390 B430 B440 B470 B490	ESSO	SPARTAN EP 68	SPARTAN EP 150
	SHELL	OMALA OIL 68	OMALA OIL 150
	CASTROL	ALPHA SP 68	ALPHA SP 150
	BP	ENERGOL GR-XP 100	ENERGOL GR-XP 150
	MOBIL	MOBILGEAR 626	MOBILGEAR 629
	AGIP	BLASIA 68	BLASIA 150
	FINA	GIRAN 100	GIRAN 150

table A

PUMP MODEL	BRAND	WORKING TEMPERATURE
		da -20°C a +150°C (viscosità olio ISO VG 150)
B550 B660 B680	ESSO	SPARTAN EP 150
	SHELL	OMALA OIL 150
	CASTROL	ALPHA SP 150
	BP	ENERGOL GR-XP 150
	MOBIL	MOBILGEAR 629
	AGIP	BLASIA 150
FINA	GIRAN 150	

table B

PUMP MODEL	LITERS
B100	0.2
B105 B110 B115	0.5
B215 B220	1
B325 B330 B390	2.2
B430 B440	4.5
B470 B490	6.7
B550	15
B660 B680	30

table C

Table C shows the amount of lubricant, expressed in litres, to be inserted in the gear box, according to the pump size, and after having removed the previous exhausted oil, as described in chapter 5.

Should it be expressly requested by the customer, the B series lobe pump can be equipped with alimentary type lubricant oil, NSF certified in H1 category.

1.4 Intended use

The "B Series Lobe Displacement Pump Unit", marketed by O.M.A.C. s.r.l., which in this documentation will be indicated with the abbreviation LDPU, has been designed and made to be assembled in industrial plants owned by third parties, to transfer volumes of fluids, compatible with the materials used during the construction of this machine: section 1.4.1 lists the recommended operational features of the LDPU, depending on the processed fluid.

The LDPU requires compliance with all technical indications in this use and maintenance manual, which in this documentation will be indicated with the abbreviation UMM, for its proper installation.

In general, the processed fluids must meet the following specifications:

Fluid properties and range of use:

- 1) **TEMPERATURE: from -35°C to +180°C**
- 2) **VISCOSITY: Maximum 200'000cPs with forced feeding**
- 3) **HARD PARTICLE SIZE: Maximum 80% of clearance between rotors (see sect.1.3.4)**

The LDPU has been designed and made for two types of use:

- **alimentary use;**
- **chemical use.**



WARNING:

The LDPU, for alimentary use, has been made to ensure a hygienic standard equal to **LEVEL 1**, on the basis of **UNI EN 13951**.

The LDPU for alimentary use and for chemical use has been designed to transfer volumes of fluids without altering the organoleptic properties nor the physical properties.



WARNING:

During its normal use, the LDPU for alimentary use and chemical use does not alter the organoleptic characteristics nor the physical characteristics of the processed fluid.

Every LDPU comes with a **technical sheet** indicating the operational features in relation to the processed fluid that must be handled (name of the fluid, viscosity range, capacity range, speed range, temperature range), as declared at the time of purchase by the Customer.

Section 1.3 shows a facsimile of the LDPU technical sheet.

Every modification to what is indicated in the specific technical sheet or variation of the machine operating parameters must be authorised in writing by O.M.A.C. s.r.l.; the absence of such authorisation is deemed "improper use" and will void any warranty or liability under way between Manufacturer and Customer.



DANGER:

Any use of the LDPU in conditions other than those indicated in "Fluid properties and range of use" and in conditions other than those indicated in the machine technical sheet is forbidden, without explicit written authorisation, issued by O.M.A.C. s.r.l.

The LDPU for alimentary use and for chemical use has NOT been designed nor built to handle pharmaceutical, explosive, etc. fluids, and in general fluids that do not comply with the indications of the specific technical sheet. In addition, the LDPU for alimentary use and chemical use has NOT been designed nor built to handle what is indicated in Regulation (EC) No. 1005/2009 of the European Parliament and the Council of 16 September, 2009, on substances that deplete the ozone layer.



ATTENTION:

It is forbidden to use the LDPU for alimentary use and chemical use to transfer the substances listed in Annex I of **Regulation No. 1005/2009**.

The pumping part of the LDPU is made up of the pump body, in which two rotors are housed (sect. 1.3.5 lists the types of rotors used), which rotate synchronised in the opposite direction to each other.

The pump body receives the process fluid from the suction inlet, originating from the plant of the Customer. During the operation of the LDPU, the cavities between the lobes of the rotors are filled with fluid and the counter-rotation of the rotors transfers the fluid to the delivery outlet of the pump body, channelling it in the plant where the LDPU is installed.

1.4.1 Recommended use guidelines for the transfer of some types of processed fluid

As an example, the following table lists some types of fluids that can be processed by the "B series lobe displacement pump", part of the LDPU; for each one, we suggest a value or range of viscosity, fluid temperature, pump rotation speed, O.M.A.C. identification code of materials for seals, gaskets and rotors (see coding section 1.2.2).

The application requested by the customer is examined by the O.M.A.C. s.r.l. Technical Office, which edits the technical sheet of the LDPU, specifically for the requested application.

Therefore, in all cases and without any exceptions, one must comply with the technical specifications, shown in the technical sheet of the B series lobe displacement pump unit, these specifications have absolute priority over the data shown in the next table.



ATTENTION

On the basis of the features of the processed fluid, O.M.A.C. identifies and uses materials compatible with the proper processability of the fluid, and these features are specifically mentioned in the **technical sheet** of the LDPU.

PRODUCTS	VISCOSITY cPs	TEMPERATURE °C	SPEED RPM	SEALS		O-RING	ROTORS	
				1°	2°		1°	2°
DAIRY PRODUCTS								
MILK	2	18	250-400	3	0	T	0	-
YOGHURT	50-150	20-40	250-350	6	3	T	0	-
BUTTER	50000	4	20-70	5	-	T	5	-
CREAM 30%	14	16	250-350	3	0	T	0	-
CURD	20-500	10	50-200	3	0	T	0	5
CONDENSED MILK	40-80	40	250-450	3	0	T	0	-

PRODUCTS	VISCOSITY cPs	TEMPERATURE °C	SPEED RPM	SEAL		O-RING	ROTORS		
				1°	2°		1°	2°	
CONDENSED MILK 75% S.S.	2000	20	200-400	5	3	T	0	-	
MELTED BUTTER	40	50	300-400	5	-	T	0	-	
PROCESSED CHEESE	30000-6500	18-80	200-400	5	-	T	0	5	
COTTAGE CHEESE	30000	18	50-150	5	-	T	0	5	
WHEY	1	20	300-500	3	0	T	0	-	
MILK ENZYMES	5	10	250-300	3	0	T	0	-	
FOOD PRODUCTS									
ICE-CREAM	400	10	200-300	5	0	T	0	5	
BROTH	1-400	20	250-450	5	3	T	0	-	
COCOA BUTTER	50-0.5	60-100	300-400	5	-	T	0	-	
ANIMAL FATS	60	40	250-400	3	-	T	0	-	
MEAT EXTRACT	10000	65	200-350	5C	-	T	0	-	
MAYONNAISE	20000	20	200-300	5	-	T	0	-	
MALT EXTRACT	3000-9500	18-60	200-300	5	1	T	0	-	
SUGAR CANDY	30000	20	150-250	5C	1	T	0	5	
MOLASSES	280-15000	40	150-300	5	1	T	0	5	
JAM	8000	16	200-350	5	-	T	0	5	
HONEY	1500	40	250-350	5	-	T	0	-	
WHOLE EGGS	150	4	200-350	6	5C	T	0	-	
BREWER'S YEAST	350	18	300-400	5	-	T	0	-	
SOYA LECITHIN	6000	50	200-300	5	-	T	0	-	
OLIVE OIL	40	38	250-350	5	3	T	0	-	
VARIOUS SEED OIL	20-60	20	250-350	5	3	T	0	-	
MINCED MEAT	100000	30	20-150	5	1	T	5	-	
PECTIN	300	30	300-400	3	5	T	0	-	
MAIZE PORRIDGE	100	100	100-200	1	0	T	0	-	
COOKIE PASTRY	5000-10000	18	50-150	5	-	T	5	0	
CHOCOLATE	200-2000	18-40	50-150	0	1	T	0	-	
ICING	500-2000	18	100-300	5	-	T	5	0	
BRINE	1	20	300-450	6	5	T	0	-	
TOMATO SAUCE	10	20	200-300	5	-	T	0	-	
DICED TOMATO	10	20	50-200	5	-	T	5	-	
TOMATO PURREÉ	7000	20	150-250	5	-	T	0	-	
TOMATO TRIPLE PURREÉ	12000	18	150-250	5	-	T	0	-	
TOMATO PASTE	200	18	200-300	5	-	T	0	-	
KETCHUP	1000	30	200-300	5	-	T	0	-	
DRINKS									
GLUCOSE	4300-8600	25-30	200-300	5C	-	T	0	-	
SORBITOL	200	20	250-350	5	-	T	0	-	
SUGAR SOLUTIONS	30° BRIX	4	10	300-400	5	-	T	0	-
	40° BRIX	10	10	300-400	5	-	T	0	-
	50° BRIX	25	10	300-400	5	-	T	0	-
	60° BRIX	60	18	300-400	5	-	T	0	-
	70° BRIX	550	18	250-350	5	-	T	0	-
	80° BRIX	6000	30	200-300	5	-	T	0	-
VINEGAR	15	20	300-500	3	-	T	0	-	
WINE	1	18	350-750	3	-	T	0	-	
SPIRITS	10-100	20	250-400	5	-	T	0	-	
ALCOHOL	1	18	300-500	3	-	T	0	-	
GRAPE JUICE	1	18	350-450	5	-	T	0	-	
BEER	1	18	300-400	3	-	T	0	-	
POTATO PUREÉ	400-4000	18	150-300	5	-	T	0	5	
FRUIT JUICE	20-80	18	250-400	5	-	T	0	-	
CONCENTRATED ORANGE JUICE	5000-500	5-20	200-300	5	-	T	0	-	

PRODUCTS	VISCOSITY cPs	TEMPERATURE °C	SPEED RPM	SEALS		O-RING	ROTORS	
				1°	2°		1°	2°
COSMETICS AND PHARMACEUTICAL PRODUCTS								
DODECILBENZENSULPHONIC ACID	6000	18	300-400	5	-	V	0	-
DETERGENTS	100-4000	18	250-400	5	3	V	0	-
HAND CREAM	800-35000	20	150-350	5	3	V	0	-
SHAMPOO	2000	20	250-350	5	3	T	0	-
HAIR GEL	5000	20	250-350	5	3	T	0	-
NAIL POLISH	10000	20	250-350	5	-	P	0	-
SOAP	3000	20	150-250	1	-	V	0	-
TOOHPASTE	100000	18	50-150	5	1	V	0	-
HYDEROGEN PEROXIDE	1	15	300-400	7	5	V	0	-
GLYCERINE	600	18	250-350	6	4	T	0	-
VASELINE	30000-500	10-40	40-350	5	-	T	0	-
INDUSTRIAL PRODUCTS								
CITRIC ACID	1	20	300-450	3	-	T	0	-
SULPHONIC ACID	125	30	250-400	5	6	V	0	-
NEUTRALIZED ETHOXYL ALCOHOLS	200-600	60-30	300-400	5	-	P	0	-
ISOPROPYL ALCOHOL	1	20	300-400	3	-	U	0	-
FLAVOUR FOR TOBACCO	10-100	20	300-450	5	3	T	0	-
FERMENTATION SOUP	20	20	250-350	3	-	T	0	-
CELLULOSE	6000-15000	18	250-350	5C	-	P	0	-
WAX	500	93	200-300	5	-	T	0	-
VINYL GLUE	1500	18	200-300	5C	1	V	0	-
UREIC PHENOLIC GLUE	600	20	200-300	5C	1	P	0	-
LATEX EMULSION	200	20	300-400	5C	-	P	0	-
PARAFFIN EMULSION	3000	18	250-350	5	-	V	0	-
ETHYLENE	20	20	250-400	3	-	T	0	-
ETHYLENE GLYCOL	10	20	250-400	3	-	T	0	-
PRINTING INK	500-2000	35	300-500	6	-	V	0	-
FLUID SILICONS	500	40	300-400	5C	-	P	0	-
DYES	1-200	20	300-500	6	-	V	0	-
ACRYLIC RESIN	5000	20	200-300	5C	1	P	0	-
ALKYL RESIN	180-900	5-40	250-350	5C	1	V	0	-
VINYL RESIN	5500	20	200-300	5C	1	V	0	-

1.5 Material specifications

Below, listed per each component (bearings box, rear cover, pumping body...) of the B Series lobe displacement pump, inserted in the LDPU, are the materials the components can be made of.

COMPONENT	USED MATERIALS
BEARING HOUSING	CAST IRON GG25
GEAR COVER B1 B2 B3 B4 SERIES	ALLOY
GEAR COVER B5 B6 SERIES	CAST IRON GG25
PUMPING CASE	AISI 316 L or in optional: HASTELLOY C276; TITANIO GRADO 5; DUPLEX SAF 2507
SHAFTS	AISI 316 L or in optional: HASTELLOY C276; TITANIO GRADO 5; DUPLEX SAF 2507
ROTORS WITH STANDARD CLEARANCES	AISI 316 L or in optional: HASTELLOY C276; TITANIO GRADO 5; lega antifrizione CY5SnBIM
ROTORS WITH INCREASED CLEARANCES	AISI 316 L or in optional: HASTELLOY C276; TITANIO GRADO 5; lega antifrizione CY5SnBIM
RUBBER COATED ROTORS	Anima in AISI 316 L + optional one of the following elastomers: N.B.R., E.P.D.M., *VITON (F.K.M.)

1.6 Occupied workplaces

The LDPU does not occupy any operator in a fixed manner. The operator occupies an occasional workplace and checks its proper operation as per the inspection and checking activity of the productive line the LDPU is part of.

1.7 Indication of the safety systems

In order to reduce the risks associated with malfunctions or misuse, the LDPU is equipped with the following security systems that are able to prevent / manage situations of danger for the operator:

- fixed joint transmission guards;
- emergency stop button;
- seal protections (excluding the LDPU version with flushed mechanical seals or double mechanical seals).

As an optional feature, the LDPU can come with the full fairing. Below there are the above mentioned safety systems.

1.7.1 Flexible transmission coupling protection

The flexible transmission coupling is protected by a removable mechanical transmission device, made up of an even coverage, accurately shaped and made of AISI 304 or aluminium, which protects the operators from contact with the rotating parts.



DANGER

It is absolutely forbidden to operate the LDPU if the safety devices have been removed.

1.7.2 Emergency stop

The emergency stop is a safety system made up of a red button, in the shape of a mushroom, on a yellow background and fitted on the electric panel, eventually supplied with the LDPU. These buttons, when present and pressed, block the work cycle of the LDPU, stopping every movement in a few seconds: therefore they have no effect on stopping the work cycle of the plant the LDPU is connected to. Therefore, to stop the operation of the plant, upstream and downstream from the pump, one must act on the plant emergency stop buttons.



DANGER

This emergency stop button IS NOT THE PLANT EMERGENCY STOP BUTTON.

To stop the operation of the plant, upstream and downstream from the pump, one must act on the plant emergency stop buttons.

The emergency stop button can only be used in situations of severe and immediate danger, which require the immediate stop of all parts. Once the button has been pressed it will stay blocked until the operator performs its manual unblocking (by rotating it in the direction indicated by the arrow printed on the control), thus maintaining the LDPU in a state of emergency.



DANGER

It is absolutely forbidden to operate the LDPU if the safety devices have been removed. Damaged safety devices must be replaced immediately. Never neutralise the safety devices.

1.7.3 Seals protections

The seals protections, re. position 239, section 1.3, are laminations made of AISI 304 or resistant plastic and are applied with screws on the bearings box to protect the operator from contact with the rotating parts of the pump: in particular they cover the rear area of the pump body where the seals supports are fitted.



DANGER

It is absolutely forbidden to operate the LDPU if the safety devices have been removed.

1.7.4 Optional features: full fairing

The full fairing of the LDPU is made up of a cover made of AISI 304 shaped appropriately, according to the dimensions of the unit, and fully covers the transmission parts during their operation, in order to protect the operators present on the plant layout, where possible, from the accidental contact with the parts.



DANGER

It is absolutely forbidden to operate the LDPU if the safety devices have been removed.

1.7.5 Optional features: electric safety devices and pressure limiters

Upon specific request of the customer company it is possible to equip the LDPU with two kinds of safety systems:

- pressure;
- electrical;

In particular the electrician called by the customer to perform this connection and qualified for the job, must design and make the electrical connections in compliance with the electrical regulations in force.

The electrician called by the customer to carry out the connections above must also envision a general reset function after the activation of the emergency state.



DANGER

It is absolutely forbidden to perform maintenance or repairs interventions on the LDPU, without having worn the PPE.



DANGER

It is absolutely forbidden to operate the LDPU after the occurrence of faults or malfunctions of the pump or equipment or devices connected to it. Damaged safety devices must be replaced immediately. Never neutralise the safety devices.

Never carry out any type of maintenance intervention directly, always contact the maintenance manager. Only this person is qualified to carry out maintenance operations professionally and in safety conditions. Before carrying out maintenance activities on the LDPU, ensure that there are no danger situations and that the machine and plant it is connected to are in emergency stop conditions.

1.8 Noise and vibrations emitted

In the envisioned conditions and methods, the sound level test was carried out to define the noise value emitted by the LDPU. The sound level test of the LDPU was performed using water as process fluid, and using the O.M.A.C. pumps testing plant.

The sound level values detected were determined applying standard EN12639 and adopting the measuring specifications of ISO 3746, and are the following:

- Sound power level equivalent to 2 meters distance in work: 65 dB(A).

1.9 Use of the personal protection equipment

During the LDPU assembly and disassembly operations, as during its routine and extraordinary maintenance, one must wear the personal protection equipment, according to the operation and risk connected to the activity performed by the appointed operator.



DANGER

It is absolutely forbidden to perform maintenance or repairs interventions on the LDPU, without having worn the PPE.

PPE	RISK	USE	EXPOSED PERSONNEL
Shoes with reinforced toe caps and non-slip soles	Lower limbs crushing	always	maintenance operator / operator
Coated safety gloves	cuts and abrasions to upper limbs	during installation or use of the unit	maintenance operator / operator
Safety goggles	Dust	during installation or use of the unit	maintenance operator / operator
Filtering face mask	exposure to chemical agents	maintenance or cleaning	maintenance operator
Neoprene safety gloves	exposure to chemical agents	maintenance or cleaning	maintenance operator
Work clothes	Dust, entangling	always	maintenance operator / operator
Ear plugs	Noise	use of the pump unit	operator



ATTENTION

To prevent mechanical risks, such as dragging, entrapment and other, do not wear accessories such as bracelets, watches, wings or chains.

1.10 Personnel training

The LDPU is made in such a manner to enable use directly by qualified personnel, for this reason one does not envision training periods, however the user, before performing any activities, must:

- carefully read this use and maintenance manual, paying attention to chapter 4, "Use of the machine",
- supervise routine maintenance operations;
- supervise the proper use of the LDPU;
- check the protection devices work.



DANGER

Children, disabled persons, persons with by-passes or cardiac problems are not admitted as operators.

Therefore it is up to the customer to train the personnel appointed to use the machine, before it is commissioned.

The operator must have a technical professional qualification, as well as suitable knowledge of general safety standards.

During the training course, the training level of the operator must be supervised by the customer company, which has the technical and organisational knowledge necessary to carry out such task.

As provided by the current regulatory framework on health and safety at work, the training process should be formalised directly by the customer.

1.11 B Series lobe positive displacement pump optional features

1.11.1 Pump in aseptic version

Excluding models B100, B660, B680, one can make the "B series lobe displacement pump", part of the machine, in aseptic version (with steam or sterile liquid barrier on the cover), on the mechanical seals and openings. The aseptic LDPU is used in transfer processes of alimentary or chemical fluids which have undergone sterilisation and must not be contaminated in any way during transfer.

In the figures below there are the indications of inlet holes (A, C, E) and outlet holes (B, D, F) of the sterile liquid or steam inside the openings (A, B, E, F) of the pumping body and the cover of the pump body (C, D). For the seals consult section 1.3.9.

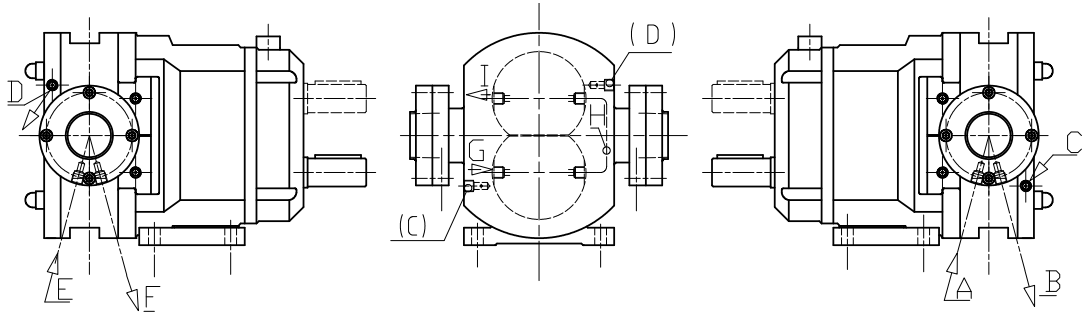

1.11.2 Pump with widened rectangular inlet port

Models B115, B220, B330, B390, B440, B490 can be made with a rectangular widened suction inlet to facilitate supply of the "B series lobe displacement pump" with very viscous products such as mixtures or thick mixtures with semi-solid pieces.

In these cases to facilitate the product to fall in, the pump is installed with openings in vertical axis directly under the hopper.

To connect the bare shaft pumps with vertical axis piping one must disassemble the foot of the pump (fixed for models B100 - B550 - B6) and fix the gear box directly to the special feet that can be supplied upon request (already included in the "vertical base"). If the "B series lobe displacement pump" is supplied bare shaft (without control unit), check the proper position of the caps and oil level.

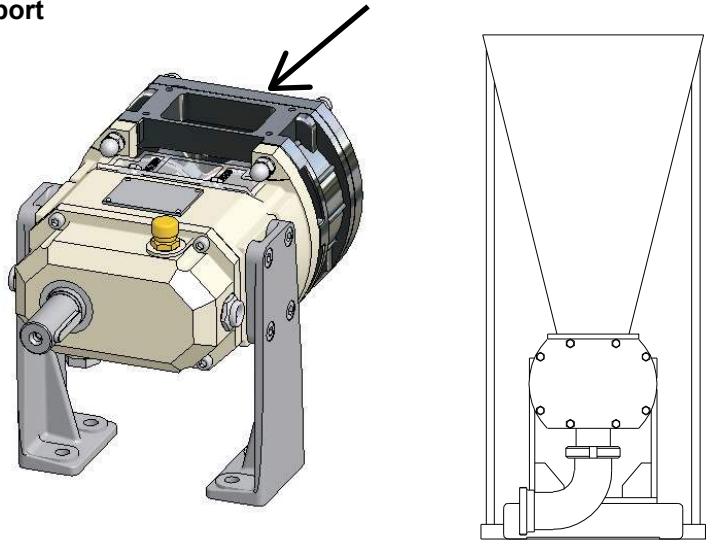

1.11.3 Pump with heating/cooling chamber on pumping case and front cover

In the event one wishes to maintain the pumped fluid at a constant temperature one can apply a cavity on the pump body and/or cover for heating / cooling liquid circulation to all the pumps of the range (excluding B100). Typical cases are the transfer of glucose, chocolate, melted fats, butter, margarine, and others.

For the dimensions of holes and the circuit diagram, consult the table in section 1.3.9.

The pipes and couplings for the circuit are not supplied with the pump.

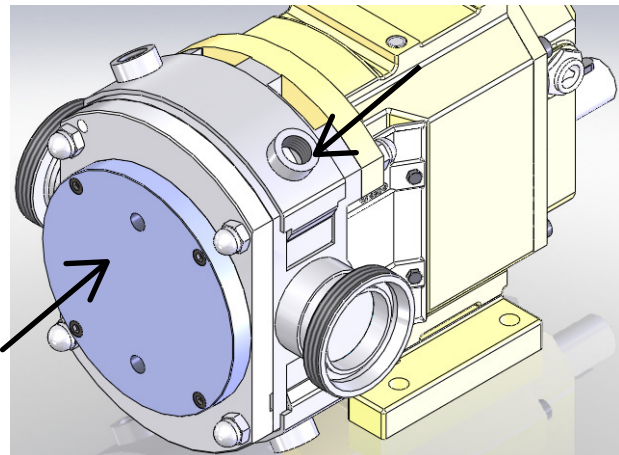

1.11.4 Pump with mechanical safety valve on front cover

One of the possible versions of the "B series lobe displacement pump" envisions the possibility to fit a mechanical safety valve on the front cover, which intercepts and dampens any pressure peaks over the limit for which the valve is set.

on the front cover, which intercepts and dampens any pressure peaks over the limit for which the valve is set.

- The safety valve, fitted directly on the front cover of the pump, is reversible and activated by a spring compressed by a regulator;
- The setting of the safety valve must be carried out on site by the Customer, because the entity of the recycling depends on the pump speed, on the specific weight and product viscosity.
- To prevent continuous vibrations, the safety valve must be adjusted in such a way that it starts working at a pressure 10% higher than the working pressure.

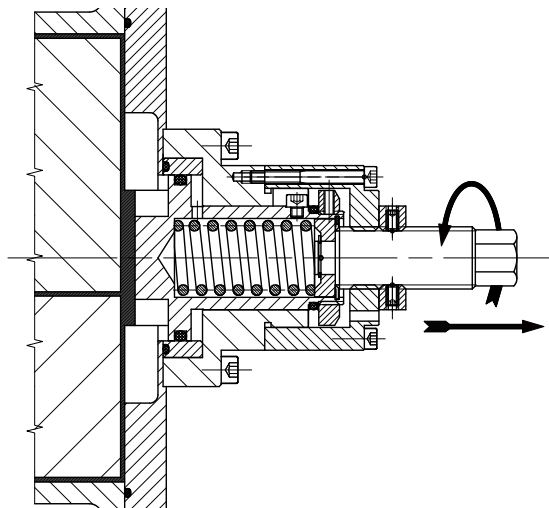

1.11.5 Pump with pneumatic safety valve on cover

One of the possible versions of the "B series lobe displacement pump" envisions the possibility to fit a pneumatic safety valve on the front cover, which intercepts and dampens any pressure peaks over the limit for which the valve is set. The valve is fitted on the cover and is made up of a cylindrical casing in which a piston slides. The fluid pressure (FP) acts on the piston face, whilst the pressure of the pneumatic plant (PP) acts on a plate fixed to the piston.

When the force that the air exercises on the plate is higher than that exercised by the liquid on the piston, the valve stays closed, otherwise the piston moves opening discharge volumes in the pumping chamber, that enable pressure balancing. Calibrating the by-pass means supplying the air chamber with a pressure value that keeps the valve closed until the pressure limit value in the pump reaches the desired value.

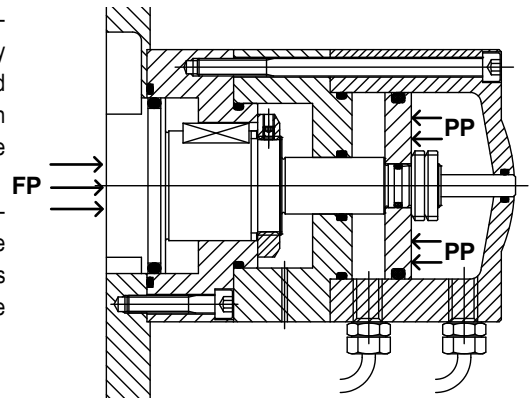

1.11.6 Pump with external mechanical bridge safety valve

The external safety valve is made up of a spring valve positioned on a pipe bridge that connects delivery and suction and can also be used as a by-pass to recycle all or part of the pumped liquid. On this valve, the adjustment of the tightness pressure is up to a spring that can be more or less compressed. The system composed in this manner is one-way so if one inverts the direction of the pump, it is essential to invert the positioning of the valve as well that, in any case, must always be on the delivery side.

One can choose various kinds of springs according to the working pressure. The adjustment must be carried out manually on site on the appropriate adjustment ring.

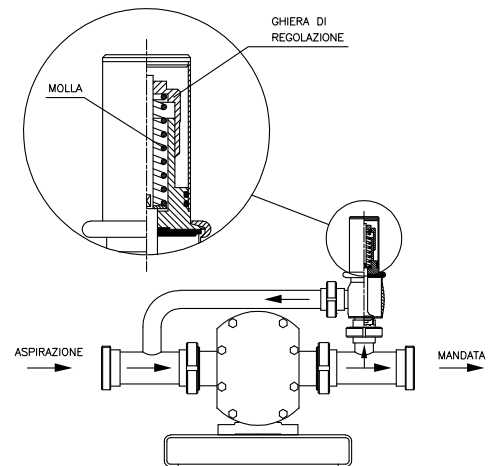

1.12 B Series LDPU optional features

1.12.1 Motorized B Series LDPU on fixed base

For customer needs, the motorised LDPU can be assembled on a base made of AISI 304 or metal, to then be fixed, via bolts, to the floor.

The motorised LDPU on a fixed base is made up as follows:

- Support base made of press-moulded sheet metal;
- B series lobe displacement pump fixed to the base;
- Speed controller / gear motor / direct electric motor / hydraulic motor / pneumatic motor fixed to the base;
- Flexible mechanical transmission coupling;
- Flexible mechanical transmission coupling protection;
- Seals protections (excluding the flushed mechanical or double mechanical seals);
- Fairing (when envisioned in the pump Unit supply, in this special version the mechanical transmission coupling protection is not installed).

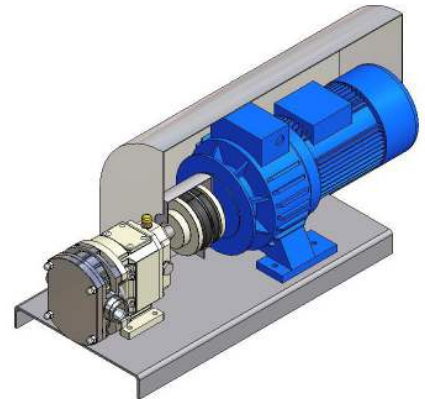

1.12.2 Motorized B Series LDPU on trolley base

For customer needs, the motorised LDPU can be assembled on a base made of AISI 304 or metal, equipped with polyamide or pneumatic wheels and trolley transportation handle.

The motorised LDPU on a trolley base is made up as follows:

- Trolley for unit transportation;
- B series lobe displacement pump fixed to the trolley;
- Speed controller / gear motor / direct electric motor / hydraulic motor / pneumatic motor fixed to the base.
- Flexible mechanical transmission coupling;
- Flexible mechanical transmission coupling protection;
- Seals protections (excluding the flushed mechanical or double mechanical seals);
- Fairing (when envisioned in the pump Unit supply, in this special version the mechanical transmission coupling protection is not installed);
- Electric control panel (not present in the version shown in the figure).

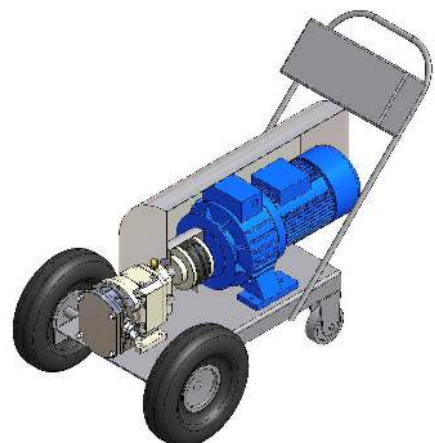

CHAPTER 2: LDPU B SERIES TRANSPORTATION

In order to ensure safety of personnel involved and considering the peculiar features of the "B series lobe displacement Pump Unit", this can be handled only by personnel used to deal with heavy material and with the suitable hoisting equipment, complete with the relative hoisting accessories. For this reason only these people can recognise and exclude dangers for third parties and/or for the handled material.

Below there is a table illustrating the mass of the various LDPU models.

LDPU B SERIES MODEL	LDPU B SERIES WEIGHT (kg.)	TYPE OF BELTS FOR LIFTING
B100	40	CHECK THE WEIGHT TO BE LIFTED
B105 B110 B115	80	
B215 B220	130	
B325 B330 B390	220	
B430 B440	350	
B470 B490	550	
B550	700	
B660 B680	1100	



DANGER

The LDPU has dimensions and weights that change according to its version and size. Take great care when handling and transporting. In particular, carefully follow all instructions for correct weight distribution.



ATTENTION

Pay utmost attention during the pump unpacking operations, described further on.

2.1 Hoisting and transportation

The "B series lobe displacement Pump Unit" is delivered to the customer inside a wooden crate (pack closed with screws; for further information please refer to section 2.4 of this use and maintenance manual).

On the basis of the weight table indications, at the beginning of this chapter, crate handling can be carried out only with a forklift with suitable capacity, supplied by the customer and driven by personnel appointed by the customer, with the requirements needed to perform all operations in safety conditions. In addition the personnel must be used to handle delicate high-tech loads.



DANGER

It is absolutely forbidden to handle the LDPU without a forklift with suitable capacity and driven by a person authorised by the customer, with the appropriate legal requirements.



ATTENTION

The crate containing the LDPU will be hoisted exclusively with a forklift.

To handle the crate, proceed as follows:

- place the forks of the forklift in correspondence of the slits between the feet of the handled crate base; slowly position under the base of the crate, ensuring that the centre-line of the forklift corresponds to the centre-line of the crate;
- hoist the LDPU carefully by about 50 millimetres, checking it is parallel compared to the lorry bed;
- reverse slowly, but evenly, until the whole crate is completely out of the way of the lorry bed;
- lower immediately (very slowly and avoiding sudden stops when lowering) until the forks of the forklift are about 50 millimetres from the ground;
- proceeding very slowly and carefully, put it in position.

Once the crate has been handled, one must place it near the LDPU installation area, in order to reduce any risks deriving from the manual handling of weights.



DANGER

During hoisting and transportation operate with great caution, in order to prevent damage to people or things.

**DANGER**

During hoisting and transportation ensure that there are no exposed persons in a dangerous area.

2.2 Delivery and unpacking

a. Delivery

All the material supplied to the customer is accurately checked by O.M.A.C. s.r.l. before shipment. Upon receipt of the LDPU ensure that the material has not been damaged during transport and that the package has not been tampered with resulting in removal of parts from the inside. If one finds the package is damaged, immediately notify the carrier and O.M.A.C. s.r.l. producing photographic documentation.

**WARNING**

With reference to the table at the beginning of this chapter, the weight of the LDPU can vary according to its version and dimensions of the products it is made up of. The units must be handled using hoisting equipment, complete with the relative accessories.

b. Unpacking

Take utmost care during the unpacking operations of the LDPU and complete the following steps:

- Open the crate, using an electric screwdriver to remove the fixing screws of the crate lid;
- Carefully remove the packaging from the LDPU;
- Check if the LDPU has any visible signs of damage;
- Place the packaging in the warehouse;
- Ensure that there are the protective plastic caps closing the connections openings;
- Ensure that the equipment supplied with the LDPU is not damaged.

In the event there is damage or parts are missing, immediately notify the carrier and O.M.A.C. s.r.l. producing photographic documentation.

Unless otherwise indicated the LDPU is shipped fully assembled, protected by a nylon sheet and set in a wooden crate. Fixing is achieved with four wood screws (see table in section 2.4); positioned in the appropriate pre-drilled holes on the LDPU support base. Should the user need to transport the LDPU one must restore the conditions described above.

**WARNING**

Keep the LDPU packaging with care, during its entire operating period. The original packaging is needed for a possible transfer of the LDPU, after its first installation.

2.3 Conditions for storage or extended interruptions of service

The LDPU has been designed for immediate use, however if the machine down time conditions should occur for long periods, one must:

- disconnect the LDPU from the electrical mains;
- following the instructions in this UMM, disconnect the LDPU from the plant it is connected to; close the suction inlets and delivery outlets with the supplied closure plugs.
- with reference to chapter 5 remove the seals and see to cleaning and sanitising them;
- lubricate and clean the seals, the pump body and the parts contained;
- put the LDPU back in its original packaging, as instructed in section 2.4, covering the electric supply and control panels with particular care;
- place the LDPU on scaffolding with suitable capacity to support the weight of the LDPU, avoiding putting weights on top of the machine;
- store the LDPU in a dry place, in its original packaging, positioning it according to the instructions shown on the crate;
- store it at a room temperature above +5°C and below +30°C, and keep it in a sheltered place away from weather or other.

**WARNING**

Place the LDPU back on the scaffolding with suitable capacity to support the weight of the LDPU.

**WARNING**

In order to keep the features of the LDPU unvaried, one must comply with all the instructions above and it is recommended to avoid particularly damp environments.

2.4 Packaging composition for future handling

In the event of transferring the LDPU, after its first installation, one must use its original transportation crate.



ATTENTION

To transport the LDPU, use the original O.M.A.C. transportation crate.

Fix the LDPU with the appropriate fixing screws, to the wooden base, placing a nylon sheet between the wooden base and the unit.



ATTENTION

Place the nylon sheet between the wooden base and the LDPU, to protect the machine from dust.

Subsequently, fit the external panels and lid on the sides of the base, which will make up the transportation packaging of the LDPU.

Below in the figure there is a typical example of the LDPU packaging.

In cases where the legislation in force requires it, one must use wooden crates that have undergone fumigation treatment.

TYPICAL PACKAGING DELIVERED	
LENGHT X WIDTH X HEIGHT of the CRATE (rif. dis. cassa Z x X x Y)	WEIGHT (kg)
36 X 26 X 39	5
45 X 35 X 44	7
65 X 43 X 54	10
76 X 42 X 64	13
86 X 61 X 74	19
100 X 42 X 53	16
120 X 80 X 117	45
130 X 53 X 64	20
160 X 63 X 74	31
160 X 63 X 135	41
200 X 71 X 104	51
230 X 72 X 95	61

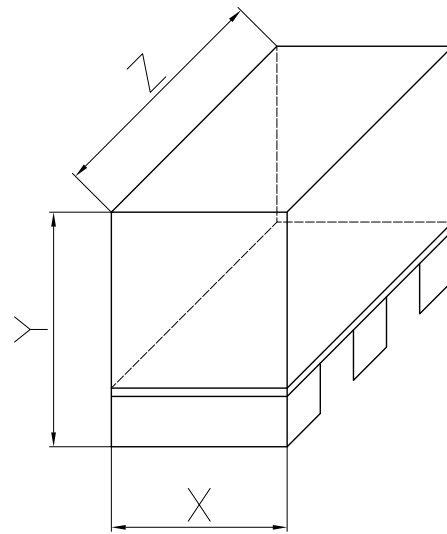

2.5 Handling of the B Series LDPU without packaging



ATTENTION

If the LDPU is equipped with the full fairing, before carrying out hoisting operations one must "disassemble" the fairing by unscrewing the hexagon screws that fix it to the support base.

To handle and hoist the LDPU without packaging, it is recommended to use hoisting equipment, complete with the relative accessories, with minimum capacity suitable for the machine to be hoisted (for weights consult the table below). Hoist and handle the pump Unit as indicated in the figure.

Only the B100 model LDPU can be handled and hoisted by hand as its maximum weight is 30 Kg. To carry out the mentioned operations use belts with adequate capacity (not supplied).



DANGER

It is forbidden to use worn hoisting belts.

All LDPU handling operations must be carried out by personnel authorised by the customer. The authorised personnel must know how to use the hoisting equipment. He must:

- use hoisting belts that are not worn;
- arrange and wrap the belt around the LDPU, as indicated in the figure on the following page;
- stretch the belts delicately;

- ensure that the belts do not strain and that their position around the LDPU does not move when hoisting; in the event there is a speed controller fitted, make sure that the belts do not strain on the control hand-wheel;
 - hoist the LDPU from the ground by about 20 - 25 cm and move it to installation place.
- The position of the centre of mass is indicative because it depends on the configuration of the LDPU.

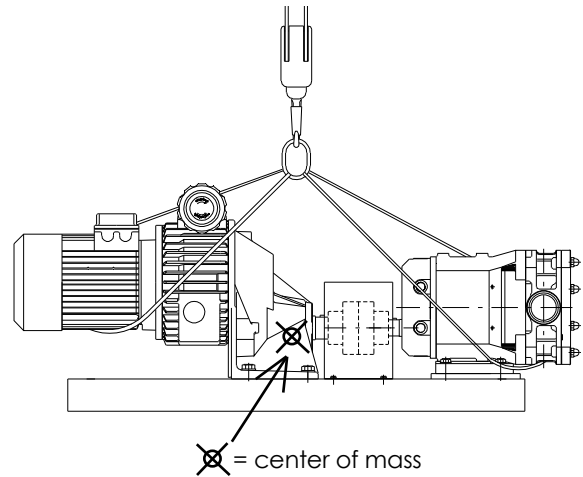

The center of mass position is indicative and it depends by LDPU configuration.



WARNING

IT IS ABSOLUTELY FORBIDDEN TO HOIST THE LDPU WITH METHODS OTHER THAN THOSE INDICATED.

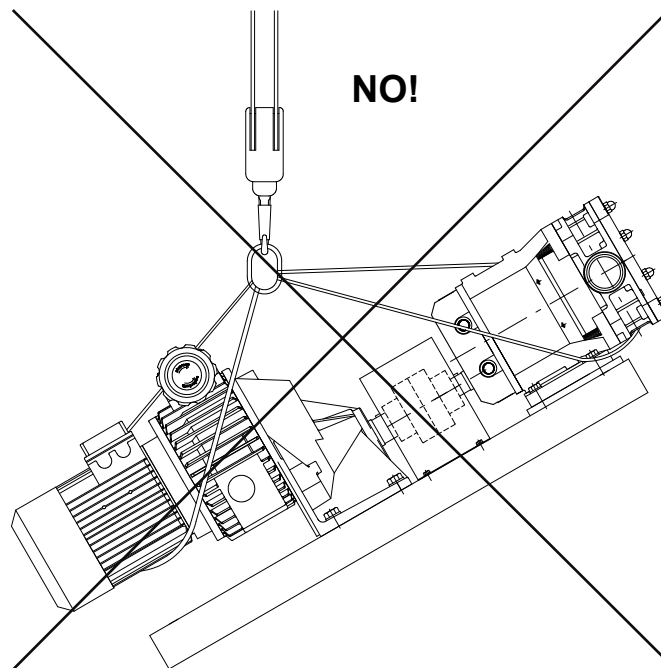

CHAPTER 3: LDPU B SERIES INSTALLATION

Before carrying out any intervention on the LDPU, read and understand this chapter in full. The operators responsible for the assembly/installation activities must have good familiarity with this type of equipment and possess recognised technical skills acquired in at least three years of similar activities, this experience is essential to limit and reduce the risks involved in assembly/installation activities.

Good knowledge of the systems and components of the LDPU is essential before carrying out any operation.



DANGER

Assembly and disassembly operations of the LDPU, performed incorrectly and / or differently from the instructions herein, could be extremely dangerous and cause injuries.

Only use the tools and utensils listed in this manual; furthermore during assembly and disassembly operations one must wear personal protection equipment, listed in section 1.9 of chapter 1.

3.1 Destination and intended environments

In order to ensure maintaining the hygienic levels required by the customer, one must install the LDPU in closed work environments, whose features comply with the requirements of this manual; the floor must be level, made of concrete, without bumps and solid enough not to collapse.

In the event the LDPU is supplied for alimentary use, the work environment must meet specific hygiene regulations requirements.



ATTENTION

The "B series lobe displacement Pump Unit" must be installed in closed work environments, not exposed to weather.



ATTENTION

Installation of the LDPU for alimentary use and its place of use must comply with the hygienic and sanitary standards required by the legislation in force.

In order to facilitate installation, use, sanitisation and maintenance of the LDPU, the Customer must prepare a space free from obstacles, with a free area of at least 3m².



ATTENTION

A work space below 3 m² may lead to incorrect installation of the LDPU as well as non-functional nor easy maintenance

3.2 Condizioni ambientali

The "B series lobe displacement Pump Unit" gives maximum performance when used in work environments that meet the following work conditions:

RELATIVE HUMIDITY BELOW 50%
ROOM TEMPERATURE BETWEEN +5°C AND +40°C



ATTENTION

IT IS FORBIDDEN TO USE THE LDPU IN ENVIRONMENTAL CONDITIONS OTHER THAN THOSE INDICATED ABOVE.



ATTENTION

ONE PROHIBITS ALIMENTARY USE OF THE LDPU IN ENVIRONMENTS THAT DO NOT MEET THE HYGIENIC AND SANITARY STANDARDS REQUIRED BY THE LEGISLATION IN FORCE.

3.2.1 Room lighting

The Customer must ensure suitable lighting of the work area, as required by EU Directives and the work legislation in force.

So not to cause reflections that can distract and dazzle workers or prevent, even partially, reading the control panels and signals, when provided by the LDPU configuration, we recommend using a diffused light.



NOTE

For maintenance and repairs interventions on the machine it is recommended to use a portable battery torch, which can be orientated in the most appropriate direction depending on the kind of intervention.

3.3 Installation and assembly

The assembly and installation of the LDPU must be performed only by qualified personnel, authorised by the Customer in compliance with the standards in force, as well as observing the instructions supplied below.

**ATTENTION**

Depending on its use, it is responsibility of the Customer to equip the installation room in order to comply with the safety and hygiene standards in force.

To operate, the LDPU needs to be connected to some utilities, such as for example:

TYPE OF UTILITY	USE
Company electrical system	electrical panel and control panel (if present) + earthing
	electric motor (in absence of control panel)
Hydraulic unit	optional features such as: hydraulic motor, seals flushing circuit
Pneumatic system	optional features such as: operation of the pneumatic safety valve
Customer plant	transfer of processed fluid
Sanitising steam system	optional features such as: aseptic version

3.3.1 Notes for the installer

Before proceeding with the installation operations of the LDPU, the installer responsible for these operations must make sure that the plant of the Customer has previously been cleaned with a piping washing cycle. During this cycle, the suction connection inlet of the plant must be connected directly to the delivery outlet of the plant, in order to carry out the preliminary washing and cleaning cycle.

This operation enables to eliminate all solid residues (dust, processing or welding scraps, etc.), produced during the pipes assembly stages, which may lead to malfunctioning of the "B series lobe displacement Pump Unit", such as possible rotor seizing.

Please note that the machine supplied by O.M.A.C. s.r.l. does not require preventive cleaning before use.

**NOTE**

The pipes cleaning and washing operation must be carried out whenever the Customer appoints the installer to perform changes on the plant, such as inserting manometers on the line, fittings or other, in order to ensure the elimination of solid particles that would lead to malfunctioning of the LDPU. THE LDPU MUST NOT UNDERGO THIS CLEANING CYCLE, MEANING THAT THE INSTALLER MUST CONNECT THE UNIT SUCTION PIPING DIRECTLY TO THE DELIVERY PIPING, THUS EXCLUDING THE LOBE DISPLACEMENT PUMP.

In addition, before production it is essential to carry out cleaning activities, as described in section 3.4.

3.3.2 Preliminary checks

To start installation activities, one must carry out some preliminary checks, relating to the work environment (with reference to section 3.2) and to the integrity of the product (with reference to section 2.2).

If this inspection should highlight the non compliance with the requirements, the Customer must:

- in the event of environment inadequacy, proceed to meet the requirements;
- if there is damage or non-compliance with the order, immediately notify O.M.A.C. s.r.l., producing photographic documentation;
- make sure that the utilities, listed above, are near the LDPU installation place and that they meet the requirements of section 1.3 and what is contained in the technical sheet.

**ATTENTION**

Failure to comply with the indications of section 1.3 and the technical sheet, may lead to anomalous operation of the LDPU (excessive noise, vibrations, etc...) or malfunctioning that can cause mechanical damages.

The Customer is responsible for the installation and proper operation of the LDPU as well as compliance with the indications of section 1.3 and the technical sheet

- ensure one can connect the LDPU to a plant that meets at least the hygienic standard of the LDPU, as shown in the declaration of conformity attached to this manual;
- ensure that the Customer plant is, from the dimensional point of view, satisfactory for the requirements of the LDPU (suction-delivery openings dimensions, piping diameter, height from the ground, unit dimensions, adequate N.P.S.H. (Net Positive Suction Head) available, linear piping to prevent back-flow, etc.)
- make sure that the paving or metallic structure on which the LDPU will be installed has a suitable capacity for supporting the weight of the unit;
- make sure there is enough work space, free from obstacles, with a free area of at least 3 m² that ensures the execution of all needed operations in complete safety conditions for the operator.

3.3.3 Installation

Below the are the activities that one must carry out, for safe and efficient installation. In particular, the instructions are divided in simple stages, as described below:

STAGE 1: PLACEMENT

Following the provisions of section 3.3.1 - Preliminary checks - and on the basis of the indications of chapter 2 of this use and maintenance manual, the operators must see to harness and handle the LDPU to place it in the position required by the Customer and specified in the plant layout.

During this stage, one will need to use a forklift with suitable capacity, driven by personnel appointed by the Customer, as per chapter 2. One must pay utmost attention in placing the LDPU in the envisioned position without intervening on the unit piping.

In the LDPU version with adjustable feet, the operators will see to measuring the height of the suction and delivery piping of the unit, after having positioned the machine. Then they must adjust the height of the unit openings at the measured height, acting on the adjustable feet. Once the second operation is complete, they can free the unit from the harnesses and proceed with stage 2 - fixing and installation, hooking the openings of the unit pumping part by screwing them onto the plant piping.



ATTENTION

Check that there are the special non-slip rubber rings in the feet.



ATTENTION

Ensure the Customer plant is aligned properly with the suction and delivery openings of the LDPU.

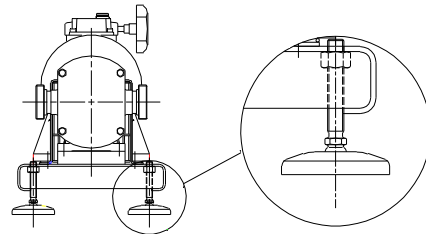

When installing the LDPU it is essential to leave a enough space for maintenance and possible removal.

During **STAGE 1** relating to the **POSITIONING** it is recommended **to avoid the followings situations:**

- in the event there are horizontal tracts of suction piping, make sure these are slightly inclined upwards to prevent air pockets from forming which would inhibit perfect priming of the LDPU;

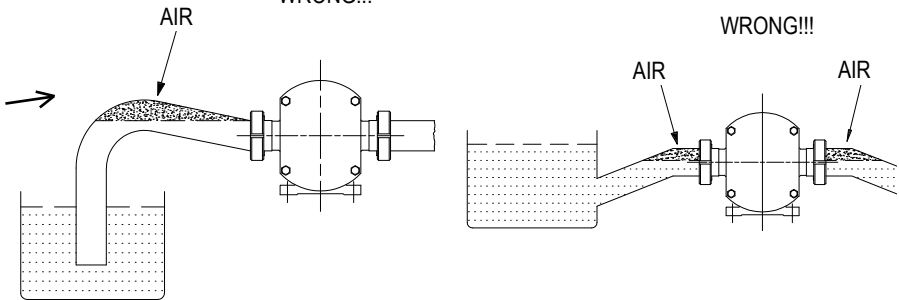

- if the LDPU is not under the head, in the suction tract provide a foot or check valve to maintain priming;

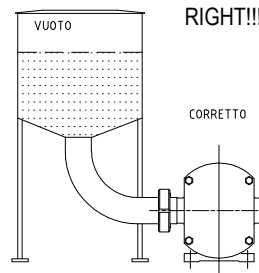
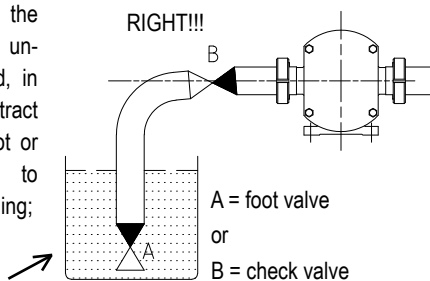

- if the LDPU is connected to a vacuum tank, one must reduce the load leaks due to the suction piping as much as possible;

- install a check valve on the delivery tract to prevent the back-flow of air or liquid during interruptions of service in order to maintain the pipes completely full and to facilitate starting when loaded.

- when applying in vertical position avoid connecting the suction inlet to the lower side and the delivery outlet to the upper side. The proper configuration consists in connecting the suction pipe to the upper side and the delivery pipe to the lower side.

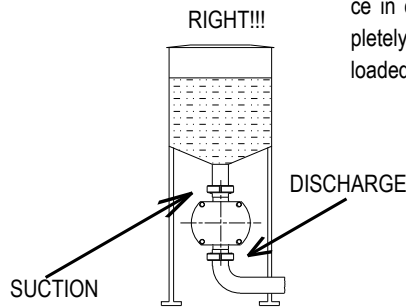
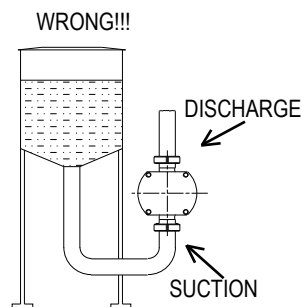

STAGE 2: FIXING AND INSTALLATION ON SITE

Once the LDPU has been positioned and aligned to the Customer plant, proceed to fix and install in the plant. Since fixing between the plant and the LDPU involves the suction inlet and delivery outlet of the pumping body, listed below are the maximum values of forces and moments, indicated with EF and EM, which the pump body and consequently the LDPU, of which it is a part, can sustain, as maximum values, during standard operation.

PUMP TYPE	FORCES [N]				TORQUES [Nm]			
	F _x	F _y	F _z	EF	M _x	M _y	M _z	EM
B100	65	55	75	113	110	85	70	140
B105 B110 B115	105	95	120	186	125	100	90	164
B215	145	130	160	252	130	110	95	172
B220	190	180	220	342	140	115	100	183
B325	210	200	250	383	150	120	110	197
B330 B390	240	230	280	435	160	130	110	206
B430 B440	255	245	300	464	175	150	130	230
B470 B490	260	250	305	472	180	150	130	234
B550	340	340	355	598	190	160	150	255
B660 B680	405	405	440	722	200	180	170	276

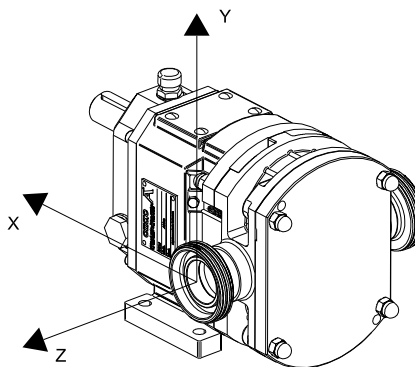

STAGE 3: CONNECTION TO THE PLANT

The suction inlet and delivery outlet of the B series lobe displacement pumps, included in the LDPU, are sized for the passage of even very viscous products, consequently the pipes do not necessarily need to be proportionate to them.

The suction and delivery pipes must be sized according to the calculations indicated in the O.M.A.C. technical manual, in relation to capacity, viscosity and pressure loss that one wants to achieve.

Displacement pumps can operate with significant pressure losses in delivery, but not in suction where it is recommended to use pipes as large and short as possible to maintain the NPSH required by the pump, part of the LDPU, lower than the NPSH available in the plant of the Customer.

The LDPU must always be installed as close as possible to the source from which it must suck up.

During **STAGE 3** relating to the **CONNECTION TO THE PLANT** it is recommended to **avoid the following situations:**

- reduce the amount of bends and narrowing as much as possible all along the line;

- using long range bends avoiding to use "T" fittings and avoid unnecessary runs.

- check the complete air tightness of the suction fittings in order not to decrease the suction power of the pump.

- The weight of the piping must not rest on the pump body and it must be connected without using force to prevent overload and distortion of the pump body.

- In the case of very long piped, install a gate on the inlet and one on the outlet of the pump, to facilitate inspection without emptying the whole unit uselessly.

- it is recommended to fit manometers and vacuum gauges as close as possible to the pump. They will be very useful to check the standard operation conditions of the pump and diagnose any inconveniences such as: pressure overloads, absence of fluid, work conditions instability, cavitation.

- protect the pump from hard solid bodies entering. Where possible install a suction filter: the filtering area must not be less than 4-5 times the pipe section to minimise pressure losses.

- where possible, fit flexible expansion joints to reduce vibrations and prevent forcing due to thermal dilations of the pipes.

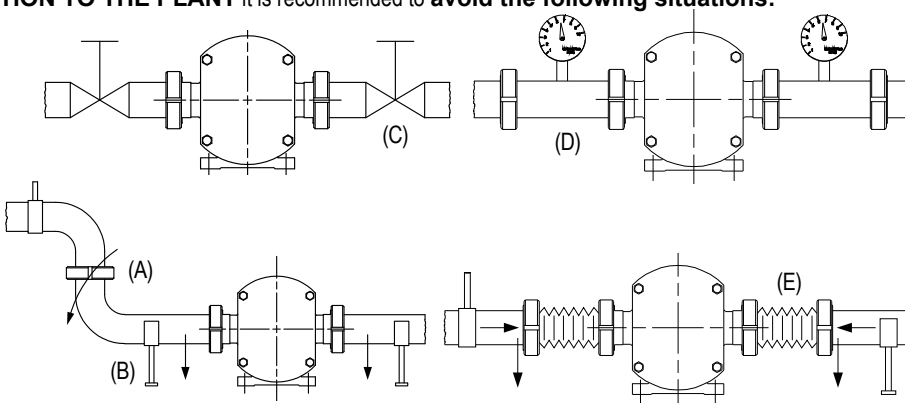

STAGE 4: FIXING THE LINE AND COMPLEMENTARY PROTECTIONS

The LDPU can be fixed in three ways, described below:



ATTENTION

If the LDPU has been supplied in the full fairing version and the fairing, or other parts of the unit, have been removed to facilitate on site positioning operations of the LDPU, one must re-fit these parts on the LDPU before completing the fixing operations of the unit.

a) Fixing onto a metallic structure.

If one must fix the LDPU to a metallic structure, use the special pre-drilled holes on the support base. With ref. to the following drawings, for the distances between the holes and the dimensions of bolted connections to use, see the table below, where for every kind of base size and its measurements "A" and "B", there are the sizes of the bolts for fixing to the metal structure:

SUPPORT SIZE	A	B	DOWEL SIZE
0	220	590	M12
1	220	590	M12
2	270	720	M12
3	330	920	M16
4	400	1100	M20
5	500	1400	M20
6	500	1400	M20
7	180	460	M10
8	450	1250	M20

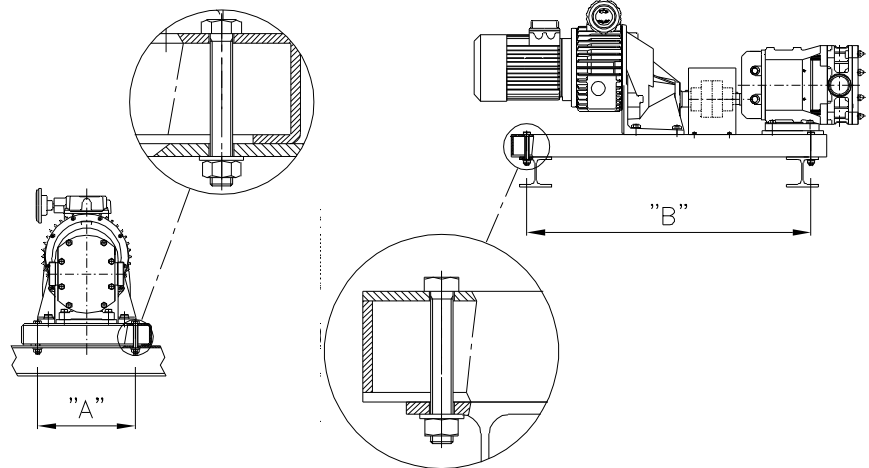

ATTENTION

In the case the LDPU is installed at a height, one must provide a containment tank for any loss of fluid or lubricant liquid, due to malfunctioning.

b) Fixing on a concrete base.

If one needs to fix the "B series lobe displacement Pump Unit" on a concrete base use the special pre-drilled holes on the support base. For the distance between holes and the dowels to use, see the table below and the instructions supplied by the dowels manufacturer.

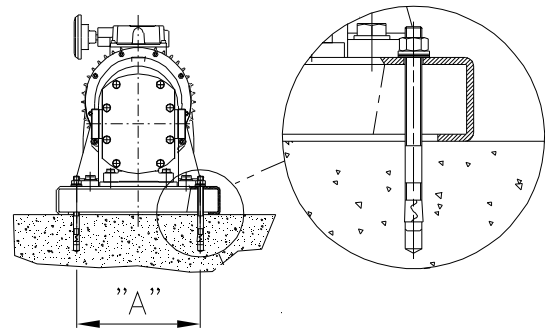

c) Support with adjustable feet

Upon explicit request of the user, the "B series lobe displacement Pump Unit" can be supplied with four adjustable feet fixed to the support base.



ATTENTION

Check that there are the special non-slip rubber rings in the feet.

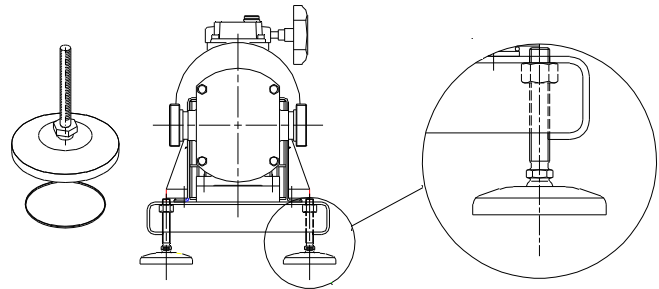

3.3.4 Accessories fitting

The LDPU can come with the following optional accessories:

- a) mechanical safety valve on the cover of the pumping body (suitable for alimentary use);
- b) pneumatic safety valve on the cover of the pumping body (suitable for alimentary use);
- c) external bridge mechanical safety valve (suitable for alimentary use);
- d) seals flushing circuit;
- e) aseptic liquid circuit;
- f) heating/cooling circuit on the cover of the pumping body or on the same pumping body.

When the LDPU is "for alimentary use" the assembly or replacement operations of the accessories, listed above, must mandatorily be followed by the sanitisation procedures described in section 3.4 of this chapter, in order to restore the hygiene and safety level required (Lev. 1 of EN 14159).

These optional features must be order together with the LDPU becoming an integral part of it. Chapter 1 gives the technical specifications of the optional features listed above, below there are the methods for adjusting or connecting the LDPU to the relative supply circuits. These operations must always be carried out after installation (re. section 3.3.2) and therefore the indications below assume proper installation and connection to the energy sources.



ATTENTION

The adjustment of the mechanical and pneumatic safety valves, described below, must be carried out by the operator in charge, before commissioning the LDPU.

A) MECHANICAL SAFETY VALVE AND ADJUSTMENT

The mechanical safety valve is made up of a cylindrical shaft in which a piston slides, on which a load spring is fitted.

The mechanical safety valve is fitted directly onto the front cover of the pump (pump body cover) and its purpose is to intercept pressure peaks of the fluid in suction, allowing part of the processed fluid to recirculate in the pumping chamber.

The adjustment of the safety valve is achieved by adjusting compression of the spring (pos. 71) and on the adjustment screw (pos. 59). The adjustment of the spring establishes the pressure value at which the mechanical safety valve opens and this adjustment must be carried out on site, as the recycle entity depends on the pump speed, on the specific weight of the fluid, as well as its viscosity.

To prevent continuous vibrations, the safety valve must be adjusted in such a way that it starts working at a pressure 10% higher than the working pressure.



ATTENTION

It is recommended to adjust the mechanical safety valve at an opening pressure 10% higher than the LDPU working pressure.



ATTENTION

The adjustment of the mechanical safety valve must be carried out on site by the Customer, since the recycle entity depends on the LDPU speed, on the specific weight of the fluid, as well as its viscosity.

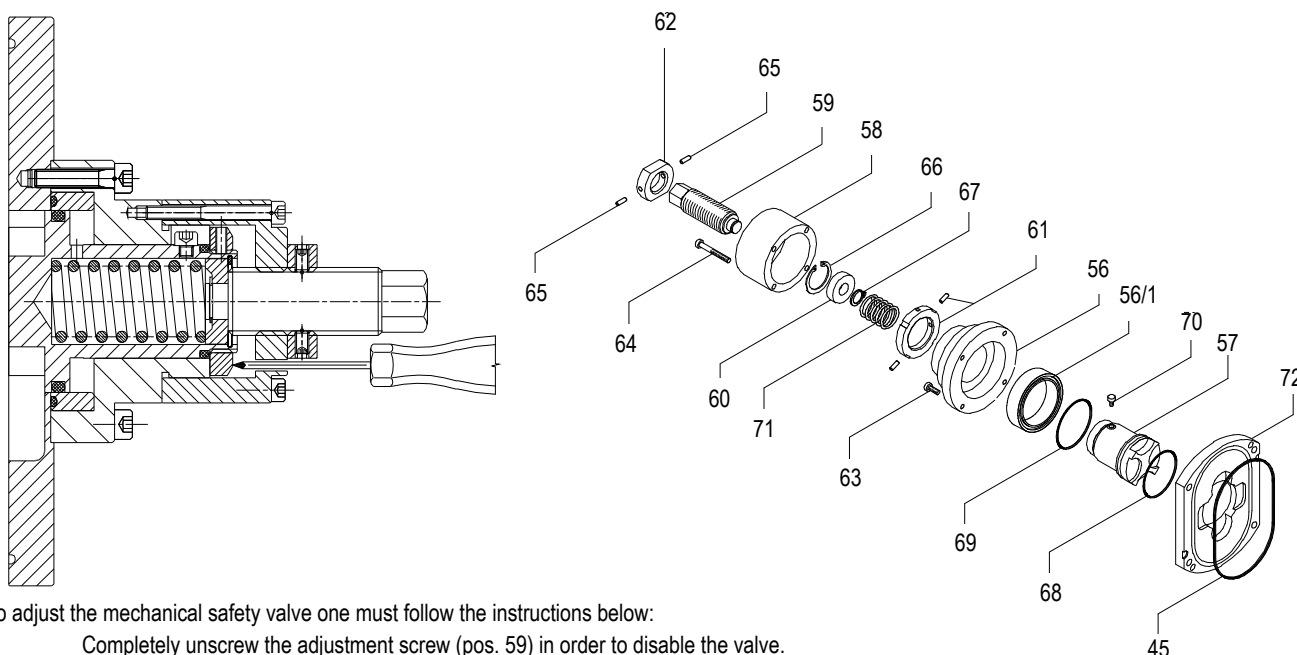

To adjust the mechanical safety valve one must follow the instructions below:

- Completely unscrew the adjustment screw (pos. 59) in order to disable the valve.
- Insert a thin rod in the inspection hole on the valve cover, pos. 58, until touching the ring.
- Start the LDPU with the safety valve spring loosened, i.e. not under pressure.
- Using a screwdriver gradually tighten the adjustment screw (pos. 59 in the figure to the right), compressing the spring and checking that the pressure in the delivery outlet of the LDPU does not exceed the allowed pressure.



ATTENTION

With reference to section 3.3.3, in order to calibrate the spring there must be appropriate manometers on the suction and delivery pipes that indicate the pressure in

- Tighten the adjustment screw until the thin rod starts to move.
- Compress the spring by 1/4 screw turn past the critical opening point to prevent vibrations.
- Position the regulator retainer (pos. 62 in the figure below) and block it with the appropriate hexagon hollow bolt (pos. 65 in the figure below).

The mechanical safety valve can also be used in manual mode, to adjust the capacity: unscrew the adjustment screw (pos. 59), release the spring pressure until moving the piston away (pos. 57) from the pumping chamber, allowing part of the pumped liquid to return into the suction chamber. This operation is not allowed for volatile fluids, such as for example solvents and fluids sensitive to temperature increase, due to continuous recirculation of the same product. For products viscosity above 15000 cPs, if one must recycle all the pumped liquid it is recommended to install a by-pass on the line, adequately proportionate, in order to allow the passage of the entire flow of the LDPU.

B) PNEUMATIC SAFETY VALVE AND ADJUSTMENT

The pneumatic safety valve is made up of a cylindrical shaft in which a piston slides and it is fitted directly onto the front cover of the pump (pump body cover). Its purpose is to intercept pressure peaks of the fluid in suction, allowing a part of the processed fluid to recirculate in the pumping chamber. The safety valve is in contact, on one side, with the processed fluid, whilst inside it is balanced with the pressure from the pneumatic circuit.

The adjustment of the pneumatic safety valve is carried out on site because it must be connected directly to the compressed air circuit on site. To adjust it is recommended to use, as reference for the pressure and sizing of the compressed air unit, the graph below showing the correspondence between the pressure inside the pump and the pressure in the valve. To prevent continuous vibrations, the safety valve must be adjusted in such a way that it starts working at a pressure 10% higher than the working pressure.

When the force the pneumatic circuit exercises on the valve is higher than that exercised by the fluid, the valve stays closed; on the contrary the valve is activated generating discharge volumes that enable balancing of forces, inside the pumping chamber.

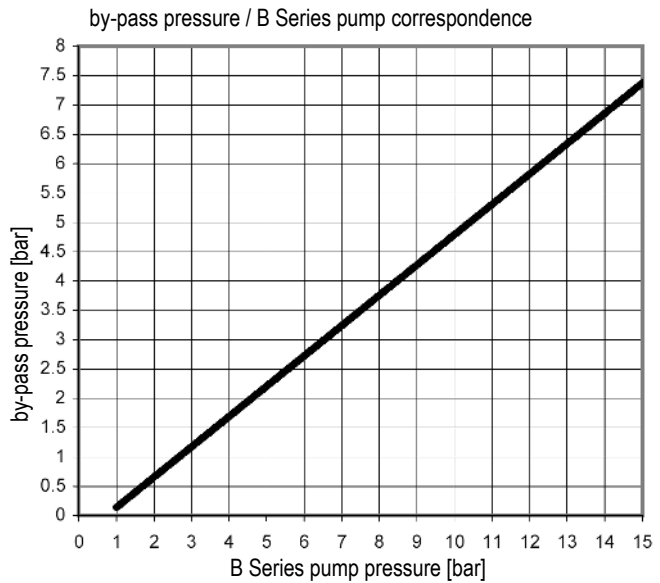
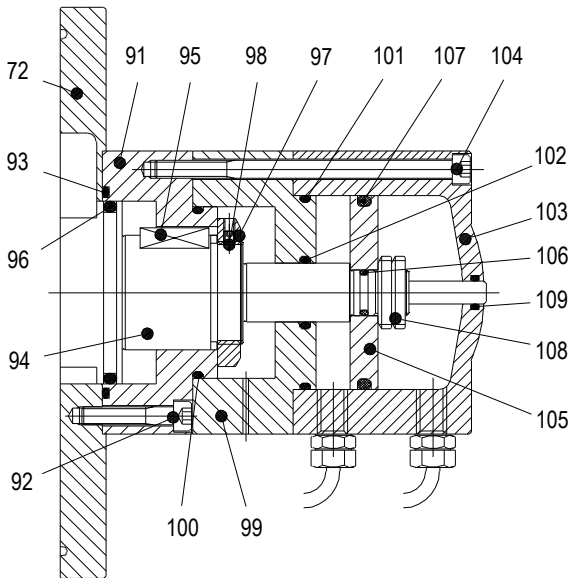

Before calibrating the pneumatic safety valve, one must calibrate the pneumatic circuit of the Customer, with a pressure value as follows:

- on the basis of the data carried in the LDPU technical sheet, detect the unit working pressure;
- with this data consult the graph shown on the next page to obtain the pressure value with which the safety valve must be calibrated.

Once one has obtained these values, proceed as indicated below:

- start the "B series lobe displacement Pump Unit" with the safety valve connected to the compressed air circuit;
- with reference to the indications on the manometer on the suction duct in proximity to the LDPU suction inlet, acting on the pneumatic pressure regulator, manually increase or decrease the pressure value of the pneumatic circuit until reaching the critical balance value, i.e. the value obtained from the graph.

To prevent continuous vibrations, the safety valve must be adjusted in such a way that it starts working at a pressure 10% higher than the working pressure.



ATTENTION

The adjustment of the mechanical safety valve must be carried out on site by the Customer, since the recycle entity depends on the LDPU speed, on the specific weight of the fluid, as well as its viscosity.



ATTENTION

The operations described herein require at least two manometers, for pressure values, installed on the suction and delivery pipes, near the LDPU openings that connect it to the plant of the Customer.

C) EXTERNAL BRIDGE MECHANICAL SAFETY VALVE AND ADJUSTMENT

The external mechanical safety valve is made up of a spring valve positioned on a pipe bridge that connects delivery and suction and can also be used as a by-pass to let all or part of the processed fluid flow back.

To adjust the external bridge safety valve act on the spring compression regulation, located on the upper part of the valve body. The system composed in this manner is one-way so if one inverts the direction of the LDPU, it is essential to invert the positioning of the valve as well that, in any case, must always be on the delivery side.

One can choose various kinds of springs according to the working pressure. The adjustment must be carried out on site, acting manually on the special adjustment ring.

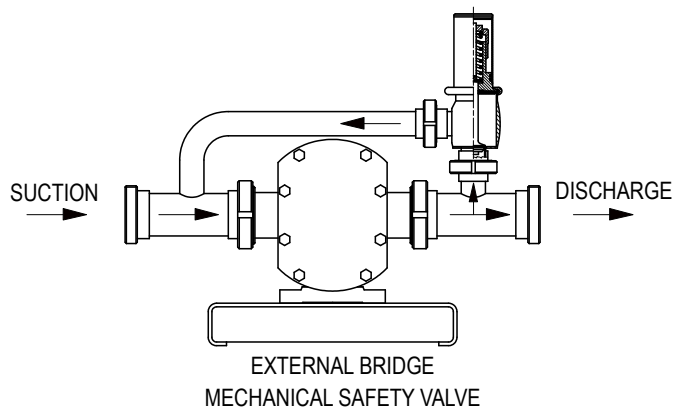

**ATTENTION**

The system composed in this manner is one-way so if one inverts the direction of the pump, it is essential to invert the positioning of the valve as well that, in any case, must always be on the delivery side.

**ATTENTION**

The adjustment of the external bridge mechanical safety valve must be carried out on site by the Customer, since the recycle entity depends on the LDPU speed, on the specific weight of the fluid, as well as its viscosity.

D) MECHANICAL SEALS FLUSHING CIRCUIT

The purpose of flushing mechanical seals is generally to cool down and lubricate the sliding faces of the mechanical seal, via forced circulation of a flushing liquid.

The flushing liquid and its distribution circuit must be provided by the Customer. **The Customer must also check, through his Technical Office, the compatibility between the flushing liquid and the process fluid, as well as the compatibility between the flushing liquid and the components of the "B series lobe displacement Pump Unit" in close contact (pumping chamber material, seals material, working temperature, etc.)**

Once this requirement has been checked and validated, the Technical Office of the Customer will see to expressly authorise the operator responsible for the installation of the LDPU to fit the flushing circuit on the seals flushing chamber and commission it, before starting the LDPU for the first time

**ATTENTION**

The operator responsible for the flushing circuit must be expressly authorised by his Technical Office to connect the flushing circuit to a system that uses "flushing liquid" compatible with the process fluid.

O.M.A.C. s.r.l. is not responsible for improper use of the flushing liquid nor for damages deriving from contamination of the process fluid.

**DANGER**

The improper use of the flushing system can cause breakage of mechanical seals resulting in damage to the LDPU and contamination of the process fluid. O.M.A.C. s.r.l. is not responsible for improper use of the flushing system.

The operator designated by the Customer must connect the flushing circuit joints to the input and output holes of the seals flushing chambers and adjust the temperature and pressure according to the type of seal fitted on the displacement pump, as described below:

- - in case of single mechanical seals the flushing pressure must be about 1.5 - 2 bar with 0.5 - 1 lt of flow-rate;
- - in the case of double mechanical seals the flushing pressure must be equal to the working pressure or higher by 1 bar, to ensure that the film created between the sliding faces of the seals is made up of the flushing liquid and not by the process fluid, which according to its chemical composition may crystallise and solidify after machine down time and generate, upon restarting the unit, a "sticking" phenomenon of the faces, causing their breakage.

The flushing temperature must be established according to the type of processed fluid and to the flushing utility: generally using liquid at room temperature - about 15° - 20° - is necessary to disperse the heat generated by friction of the seals faces, or vice-versa, using liquid at higher temperatures, for example 80° - 90°, can be useful for melting, removing, cleaning and lubricating the seals faces.

The dimensions of the inlet and outlet holes joints of the flushing circuit are listed in the table in section 1.3.9 in chapter 1.

Below there is an illustration of the two kinds of flushing:

flushing diagram for low pressure seals

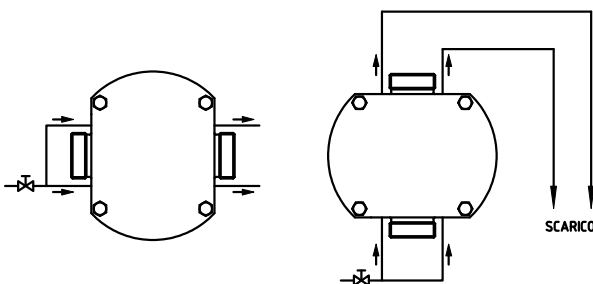

flushing diagram for double seals with circuit under pressure

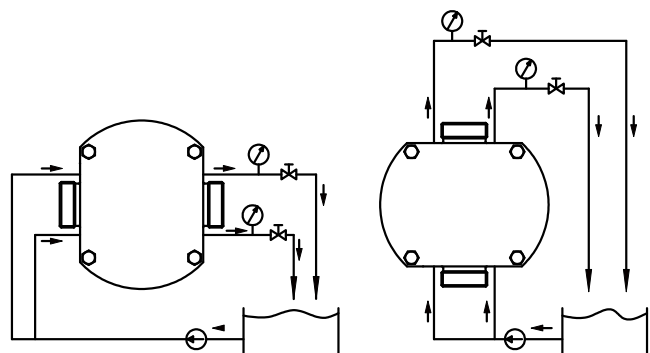
**E) ASEPTIC LIQUID CIRCUIT**

The aseptic liquid circuit (water steam), connected to the components of the LDPU which will come into contact with the process fluid (pump body, unit connection openings, sealing parts) are used to ensure the product is aseptic, during its transfer cycle performed by the LDPU, from its suction inlet to its delivery outlet.

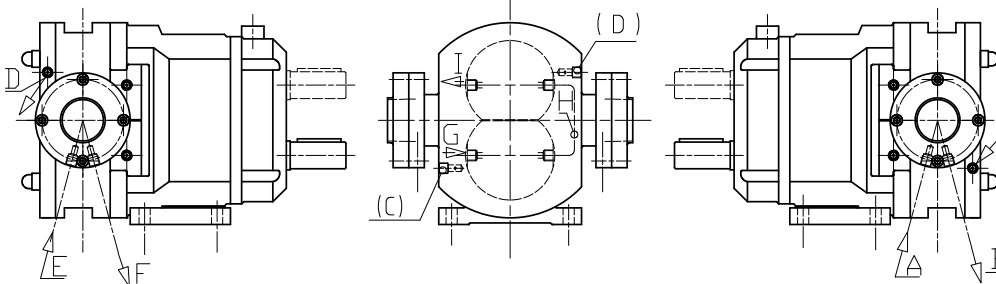

If the displacement pump, part of the LDPU, is supplied in "aseptic" version, i.e. with front cover and suction and delivery connection openings equipped with internal duct for steam barrier, the Customer must connect the water steam source and relative delivery to the joints of the

above-mentioned circuit, to make the components of the lobe displacement pump aseptic.

This necessitates the presence of a steam circuit inside the plant of the Customer.

The dimensions of the inlet and outlet holes joints of the aseptic circuit are listed in the table in section 1.3.9 in chapter 1.

F) COVER AND PUMPING CHAMBER HEATING/COOLING CIRCUIT

The heating / cooling circuit must be connected to the auxiliary circuit of the plant in which the LDPU is located and must be commissioned by the designated operator before starting the plant concerned by the process fluid, in order to adapt (raise, if the intent is to heat or lower, if the intent is to cool down) the temperature of the components of the B series lobe displacement pump, affected by contact with the process fluid at the temperature of the same process fluid.

The dimensions of the inlet and outlet holes joints of the heating / cooling circuit of the cover and pumping chamber are listed in the table in section 1.3.9 in chapter 1.

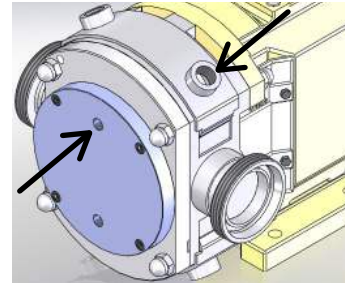

3.4 Cleaning and hygiene of the LDPU

Listed below are the methods for cleaning the LDPU according to its operation environment: alimentary with hygiene level 1 or chemical.



ATTENTION

The Customer must also check, through his Technical Office, the compatibility between the C.I.P. liquid and the components of the "B series lobe displacement Pump Unit" in close contact (pumping chamber material, seals material, working temperature, etc.)

3.4.1 LDPU for alimentary use

To ensure hygiene and healthiness of the processed alimentary fluid, installation and start-up of the "B series lobe displacement Pump Unit" requires preventive cleaning and sanitisation activities, these activities must take into account the particular features of the processed alimentary fluid, as well as reaction times defined by the manufacturer of the detergent and sanitising product used and mentioned in the technical sheet. For this reason the cleaning and sanitisation activities described in this section must be carried out in each of the following situations:

- after the installation of the LDPU;
- after a long down time of the LDPU;
- before every change of processed alimentary fluid;
- at the end of a work shift;
- when otherwise required by the characteristics of perishable processed alimentary fluid (short machine down times, changes in temperature, etc);
- after routine/extraordinary maintenance.
- Once it has been installed in the plant of the Customer, the LDPU becomes an integral part both of the process unit and of the scheduled cleaning system. In any case, as required by UNI EN standards for cleaning / sanitising this product, the level of hygiene of the LDPU can be identified as LEVEL 1, so the activities described below are conducted to restore the same level of hygiene.

Generally the products used for cleaning and sanitising are of the following types:

- descaling detergents (cleaning of surfaces in contact with alimentary fluid after a long machine down time);
- degreasing detergents (external cleaning, cleaning of surfaces in contact with alimentary fluid);
- sodium hypochlorite based detergents in aqueous solution (5%) (sanitisation of surfaces in contact with alimentary fluid after a long machine down time);
- detergents with quaternary ammonium salts in aqueous solution (5%) (sanitisation of surfaces in contact with alimentary fluid after a long machine down time);
- please note that the LDPU requires cleaning and sanitising after a long machine down time or routine/extraordinary maintenance, one must precede these activities by washing with a descaler, to be left to act according to the times indicated by the manufacturer.

Cleaning activities must be carried out by the operators in charge of running the plant in which the LDPU is integrated, therefore they must be read, understood and carried out carefully by these operators.

Cleaning activities, if manual, must be carried out with the plant switched off and insulated from its energy sources.



ATTENTION

Cleaning activities must be carried out by the operators in charge of running the plant, therefore they must be read, understood and carried out carefully by these operators.

**ATTENTION**

The hygiene level of the LDPU can be identified as LEVEL 1, according to UNI/EN standards, therefore the activities described below are carried out in order to restore the same hygiene level.

Cleaning and sanitising activities that concern the “B series lobe displacement Pump Unit” are divided according to two different contexts:

- external: DO NOT affect surfaces in contact with alimentary fluid;
- internal: affect surfaces in contact with alimentary fluid.

Below are the descriptions of the cleaning and sanitisation methods mentioned above.

3.4.1.1 External cleaning instructions

These cleaning activities are carried out manually, using the instruments needed to enact them, provided by the Customer and indicated below:

- pressure washer connected to waterworks under pressure;
- NON aggressive detergent with degreasing surfactants;
- wear the P.P.E. already provided by the Customer and Manufacturer of the plant in which the LDPU becomes an integral part, PPE that must take into account what is indicated in the safety sheet of the detergent used.

After having put the detergent in the pressure washer and before going any further, cover the electric control panel, the electric motor and machine wiring, paying particular attention to the cables input into the shunt/connection boxes, with nylon sheets, fastened securely.

Paying attention to NOT direct the water jet onto parts covered with nylon sheets and indicated above, switch on the pressure washer and proceed with the cleaning the LDPU, orientating the water jet under pressure only towards the external surfaces of the pump, part of the LDPU, as well as the fixing base on which the pump is fixed.

**ATTENTION**

DO NOT direct the jet onto parts covered with the nylon sheets such as: electric control panel, electric motor and wiring in the machine. Pay utmost attention to NOT wet the cables input into the shunt/connection boxes.

If required by the manufacturer of the detergent used and if specified on the relative information sheet, rinse using cold water only.

3.4.1.2 Internal cleaning instructions

The cleaning and sanitisation activities of the surfaces in contact with alimentary products develops according to the following diagram, following the indicated frequency:

WASHING STAGES	DETERGENT AGENT	WHEN TO USE	PERIODICITY
STAGE 1	DESCALING	FOLLOWING LONG MACHINE DOWN TIME	EVERY 3 MONTHS
STAGE 2	DEGREASING	TO REMOVE RESIDUES OF PROCESS FLUID IN CONTACT WITH THE PROCESS FLUID	ALWAYS
STAGE 3	SODIUM HYPOCHLORITE BASE	AFTER STAGE 2, TO SANITISE SURFACES	ALWAYS
STAGE 4	WATER	TO ELIMINATE RESIDUES OF DETERGENT	ALWAYS
STAGE 5	STEAM	TO STERILISE THE COMPONENTS IN CONTACT WITH THE PROCESS FLUID	ALWAYS

Cleaning the surfaces in contact with the transferred process fluid articulates further into two different methods, as shown below:

- **CIP/SIP;**
- **manual cleaning.**

Below the two methods are explained better. - ;

3.4.1.2.1 Internal cleaning: CIP (Cleaning In Place)/SIP (Sterilising In Place)

As well known, the CIP/SIP is a cleaning method of the entire plant that does NOT require the disassembly of parts and/or accessories inside the same plant. The CIP/SIP is therefore a cleaning and sanitisation activity of the plant of which the LDPU is an integral part and therefore in turn affected by it.

**ATTENTION**

Before carrying out CIP/SIP one must perform each of the operations described below.

If the LDPU has been supplied with one or more accessories listed in section 3.3.3. of this UMM, before starting CIP/SIP, check the following:

- adjust the pressure of the safety valves (re. section 3.3.3 letters a,b,c) at a pressure value below the maximum pressure of the same CIP/SIP, thus ensuring opening of the valve when washing the plant;
- ensure that the auxiliary units (flushing unit, cover heating and aseptic circuit), if present, are connected to the pump and work;
- if the customer envisions the LDPU to actively participate in the CIP/SIP, activate operation of the same LDPU.

On the basis of the indications given by the plant manufacturer, activate the CIP/SIP.

The duration of CIP/SIP depends on the type of process fluids treated. In order to ensure sanitisation of the LDPU, O.M.A.C. s.r.l. recommends the CIP/SIP to last at least 1 hour.



ATTENTION

At the end of the CIP/SIP, but before restarting the plant, the safety valves must be re-set at the working pressure value, this activity must follow what is indicated in section 3.3.3 of this manual.

3.4.1.2.2 Internal cleaning: manual cleaning

Manual cleaning activities must be carried out with the plant switched off and insulated from its energy sources; in addition the operator must wear P.P.E. as indicated in chapter 1, section 9.

Manual cleaning activities entail:

- a) disassembly of mechanical elements;
- b) treated alimentary process fluids removal/extraction operations;
- c) washing and sanitisation activities;
- d) rinsing;
- e) sterilisation;
- f) reassembly of the previously removed mechanical elements.

Wear the P.P.E. as per Chapter 1, Section 9, paying attention to identify, on the basis of the thermal features of the treated process fluids, the gloves to wear;



ATTENTION

Cleaning activities must be carried out by the operators in charge of running the plant, therefore they must be read, understood and carried out carefully by these operators.



DANGER

Cleaning and sanitisation activities must be carried out with the plant switched off and insulated from its energy sources: electrical, pneumatic, hydraulic. The operator in charge of this activity is obliged to wear the P.P.E. indicated in chapter 1, section 9, in order to ensure their safety.

a) The disassembly activities refer to the following mechanical elements:

- front cover;
- rotor blocking nuts;
- rotors;
- gaskets;
- any optional features (mechanical or pneumatic safety valve).

These elements must be disassembled following the indications contained in chapter 5, section 5.8, 5.9, 5.10 of this manual.



ATTENTION

During disassembly and assembly operations of the components listed under letter a), strictly follow the indications in sections 5.8, 5.9, 5.10.

b) The alimentary process fluids removal activities consist in manually removing most of the fluid present and seeing to its disposal.

c) Washing and sanitisation activities concern the previously disassembled single components, as well as the pumping chamber. Using a water and degreasing detergent solution, wash the single components and the pumping chamber, paying particular attention to the seals area and shafts threaded area.

d) Wash with plenty of aqueous solution until the visible process alimentary fluid is completely removed.

Once the alimentary process fluid has been removed from the contact surfaces, sanitise all the components that come into contact with the fluid. To do this:

- prepare aqueous solution of sodium hypochlorite (5%);
- sanitise all surfaces in contact with the alimentary process fluid carrying out the operation for at least 15 minutes



ATTENTION

Sanitise all surfaces in contact with the alimentary product proceeding for at least 15 minutes

- with cold running water, rinse all the previously sanitised surfaces, making sure all traces of sanitiser are removed.

e) Sterilise the previously sanitised surfaces with water steam.

f) Reassemble the previously removed mechanical elements following the indications contained in Chapter 5, section 5.8, 5.9, 5.10 of this UMM.

After having assembled the clean and sanitised pump components, remove the protective sheets, placed on the electric panel, electric motor and cable shunt/connection boxes and subsequently connect to the energy sources, disconnected before starting manual cleaning.

3.4.2 LDPU for chemical use

To ensure cleaning the process chemical fluid, LDPU installation and starting requires prior cleaning activity.

The cleaning activities described herein must be carried out in each of the following situations:

- after the installation of the LDPU;
- after a long down time of the LDPU;
- before every change of processed chemical fluid;
- at the end of a work shift;
- when otherwise required by the characteristics of perishable processed chemical fluid (short machine down times, changes in temperature, etc);
- after routine/extraordinary maintenance.

Once it has been installed in the plant of the Customer, the LDPU becomes an integral part both of the process unit and of the scheduled cleaning system.

Generally the products used for cleaning are of the following types:

- descaling detergents (cleaning of surfaces in contact with alimentary fluid after a long machine down time);
 - degreasing detergents (external cleaning, cleaning of surfaces in contact with chemical fluid);
 - sodium hypochlorite based detergents in aqueous solution (5%) (sanitisation of surfaces in contact with chemical fluid after a long machine down time);
 - detergents with quaternary ammonium salts in aqueous solution (5%) (sanitisation of surfaces in contact with chemical fluid after a long machine down time);
- please note that the LDPU requires cleaning and sanitising after a long machine down time or routine/extraordinary maintenance, one must precede these activities by washing with a descaler, to be left to act according to the times indicated by the manufacturer.

Cleaning activities must be carried out by the operators in charge of running the plant in which the LDPU is integrated, therefore they must be read, understood and carried out carefully by these operators.

Cleaning activities, if manual, must be carried out with the plant switched off and insulated from its energy sources.



ATTENTION

Cleaning activities must be carried out by the operators in charge of running the plant, therefore they must be read, understood and carried out carefully by these operators.

The cleaning activities that concern the LDPU are divided according to two different contexts:

- external: DO NOT affect surfaces in contact with chemical fluid;
- internal: affect surfaces in contact with chemical fluid.

Below are the descriptions of the cleaning methods mentioned above.

3.4.2.1 External cleaning instructions

The activities described herein must be carried out with the unit switched off and insulated from its energy sources and are intended to be performed by the operators responsible for running the plant of which the LDPU is an integral part, therefore they must be read, understood and performed carefully by these operators.

These cleaning activities are carried out manually, using the instruments needed to enact them, provided by the Customer and indicated below:

- pressure washer connected to waterworks under pressure;
- NON aggressive detergent with degreasing surfactants;
- wear the P.P.E. already provided by the Customer and Manufacturer of the plant in which the LDPU becomes an integral part, PPE that must take into account what is indicated in the safety sheet of the detergent used.

After having put the detergent in the pressure washer and before going any further, cover the electric control panel, the electric motor and machine wiring, paying particular attention to the cables input into the shunt/connection boxes, with nylon sheets, fastened securely.

Paying attention to NOT direct the water jet onto parts covered with nylon sheets and indicated above, switch on the pressure washer and proceed with the cleaning the LDPU, orientating the water jet under pressure only towards the external surfaces of the pump, part of the LDPU, as well as the fixing base on which the pump is fixed.



ATTENTION

DO NOT direct the jet onto parts covered with the nylon sheets such as: electric control panel, electric motor and wiring in the machine.

Pay utmost attention to NOT wet the cables input into the shunt/connection boxes.

3.4.2.2 Internal cleaning instructions

The cleaning and sanitisation activities of the surfaces in contact with alimentary products develops according to the following diagram, following the indicated frequency:

WASHING STAGES	DETERGENT AGENT	WHEN TO USE	PERIODICITY
STAGE 1	DESCALING	FOLLOWING LONG MACHINE DOWN TIME	EVERY 3 MONTHS
STAGE 2	DEGREASING	TO REMOVE RESIDUES OF PROCESS FLUID IN CONTACT WITH THE PROCESS FLUID	ALWAYS
STAGE 3	SODIUM HYPOCHLORITE BASE	AFTER STAGE 2, TO SANITISE SURFACES	ALWAYS
STAGE 4	WATER	TO ELIMINATE RESIDUES OF DETERGENT	ALWAYS

Cleaning the surfaces in contact with the transferred process fluid articulates further into two different methods, as shown below:

- **CIP;**
- **manual cleaning.**

Below the two methods are explained better.

3.4.2.2.1 Internal cleaning: CIP

As well known, the CIP/SIP is a cleaning method of the entire plant that does NOT require the disassembly of parts and/or accessories inside the same plant. The CIP is therefore a cleaning activity of the plant of which the LDPU is an integral part and therefore in turn affected by it.



ATTENTION

Before carrying out CIP one must perform each of the operations described below.

If the LDPU has been supplied with one or more accessories listed in section 3.3.3 of this UMM, before starting CIP, check the following:

- adjust the pressure of the safety valves (re. section 3.3.3 letters a,b,c) at a pressure value below the maximum pressure of the same CIP, thus ensuring opening of the valve when washing the plant;
- ensure that the auxiliary units (flushing unit, cover heating and aseptic circuit), if present, are connected to the pump and work;
- if the customer envisions the LDPU to actively participate in the CIP, activate operation of the same LDPU.

On the basis of the indications given by the plant manufacturer, activate the CIP.

The duration of CIP depends on the type of process fluids treated. In order to ensure sanitisation of the LDPU, O.M.A.C. s.r.l. recommends the CIP to last at least 1 hour.



ATTENTION

At the end of the CIP, but before restarting the plant, the safety valves must be re-set at the working pressure value, this activity must follow what is indicated in section 3.3.3 of this manual.

3.4.2.2.2 Internal cleaning: manual cleaning

Manual cleaning activities must be carried out with the plant switched off and insulated from its energy sources; in addition the operator must wear P.P.E. as indicated in chapter 1, section 9. Manual cleaning activities entail:

- a) disassembly of mechanical elements;
- b) chemical process fluid removal/extraction operations;
- c) washing and sanitisation activities;
- d) rinsing;
- e) reassembly of the previously removed mechanical elements.

Wear the P.P.E. as per Section 1.9 of Chapter 1, paying attention to identify, on the basis of the thermal features of the process fluids, the gloves to wear;



ATTENTION

Cleaning activities must be carried out by the operators in charge of running the plant, therefore they must be read, understood and carried out carefully by these operators.



DANGER

Manual cleaning activities must be carried out with the plant switched off and insulated from its energy sources: electrical, pneumatic, hydraulic. The operator in charge of this activity is obliged to wear the P.P.E. indicated in chapter 1, section 9, in order to ensure their safety.

a) The disassembly activities refer to the following mechanical elements:

- front cover;
- rotor blocking nuts;
- rotors;
- gaskets;
- any optional features (mechanical or pneumatic safety valve).

These elements must be disassembled following the indications contained in chapter 5, section 5.8, 5.9, 5.10 of this manual.



ATTENTION

During disassembly and assembly operations of the components listed under letter a), strictly follow the indications in sections 5.8, 5.9, 5.10.

- b) The chemical process fluids removal activities consist in manually removing most of the fluid present and seeing to its disposal.
- c) Washing and sanitisation activities concern the previously disassembled single components, as well as the pumping chamber. Using a water and degreasing detergent solution, wash the single components and the pumping chamber, paying particular attention to the seals area and shafts threaded area.
- d) Wash with plenty of aqueous solution until the visible process chemical fluid is completely removed.

Once the chemical process fluid has been removed from the contact surfaces, clean all the components that come into contact with the fluid.

To do this:

- prepare aqueous solution of sodium hypochlorite (5%);
- clean all surfaces in contact with the chemical process fluid carrying out the operation for at least 15 minutes;



ATTENTION

Sanitise all surfaces in contact with the chemical product proceeding for at least 15 minutes.

- with cold running water, rinse all the previously cleaned surfaces, making sure all traces of sanitiser are removed.
- e) Reassemble the previously removed mechanical elements following the indications contained in Chapter 5, section 5.8, 5.9, 5.10 of this UMM. After having assembled the clean pump components, remove the protective sheets, placed on the electric panel, electric motor and cable shunt/connection boxes and subsequently connect to the energy sources, disconnected before starting manual cleaning.

3.5 Connection to energy sources

Below there are the procedures for connecting the LDPU to the energy sources, needed for its proper operation.

3.5.1 Connection to the electrical system

Connection to the electrical mains must be carried out by the operator responsible for the assembly/installation activities, in compliance with the strictest technical standards, the connection must be carried out after the hydraulic connection. This personnel must have full knowledge of the rules for use and operation of electrical equipment supplied with the LDPU.

The Customer must organise the plant layout so as to provide:

- a manual supply sectioning device,
- over-current and overload protection,
- devices that prevent spontaneous restarting.

Before carrying out the connection one must ensure that:

- the frequency and voltage of the Customer plant corresponds to the data carried in the "technical sheet" of the LDPU;
- The material used for the electrical connection has an IP degree suitable for the environment in which it is installed, in order to prevent the conductors from overheating.

The connection of cables to the terminal board can be carried out both in triangle or star, complying with the data carried on the motor nameplate according to the mains voltage.

The connection of electric wiring can take place as follows:

- 1) LDPU with electric panel;
- 2) LDPU without electric panel;

In particular, in case 1), in presence of the electric panel, the operator must carry out the following operations:

- section the electric mains in order to insulate the sockets from the industrial electricity supply;
- connect the plug;
- power the electricity sockets;

this way even the LDPU electric control panel is powered.



ATTENTION

Operate with caution: the LDPU and the control actuators are powered electrically.

In case 2), in absence of the electric panel, the operator must see to power the electric motor on the basis of the indication contained in the electric motor Use and Maintenance Manual (UMM available in electronic version on the Internet websites of the relative manufacturers).

One must also provide earthing for the motor, using the jack provided on the motor and an adequate section conductor: the connection must be carried out with a type NO7Vv mm² 35 section stranded wire with yellow-green insulation and crimped wire heads.



ATTENTION

Before carrying out any operation, check that the features of the distribution network (voltage and frequency) correspond to the data on the motor plate or electric panel.



ATTENTION

O.M.A.C. s.r.l. is NOT responsible for damages caused by incorrect installation of the electric energy supply, in case of failure to comply with the technical standards in force.

3.5.2 Connection to the hydraulic system

Before going further one must check compliance with the indications of section 3.3.2 of this chapter.

If the indications above have been observed, one can proceed with the following activities:

- a) connection of mechanical seals flushing;
- b) connection of pumping chamber cover heating/cooling;
- c) connection of pumping body heating/cooling.



ATTENTION

It is essential, as indicated in section 3.3.1, before carrying out the hydraulic connections, to wash the plant - in order to clean the pump -, and the hydraulic connection lines, from dirt residues such as dust, sand, process scraps, etc.

a) with reference to the drawing to the side and the dimensions of the threaded joints, shown in the table in section 1.3.9, identify the flushing connection points on the LDPU as well as the types of fittings to use.

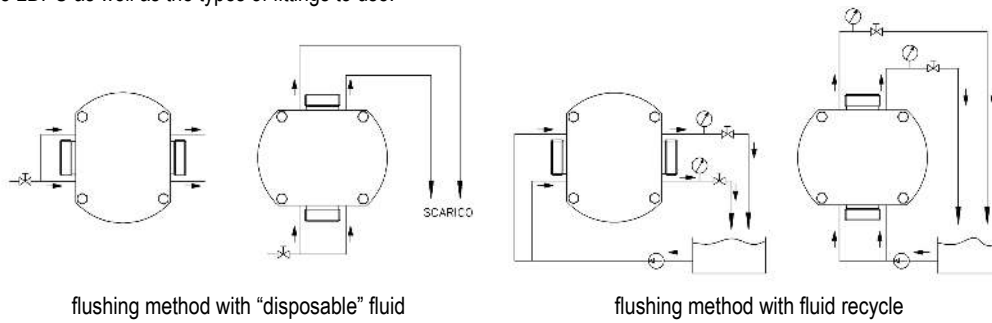

b) connection of pumping chamber cover heating/cooling;

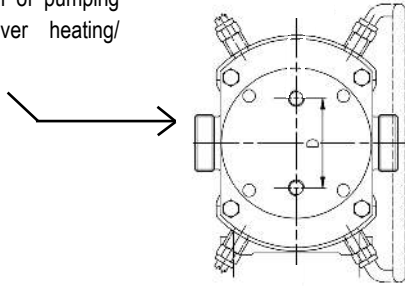

c) connection of pumping body heating/cooling;

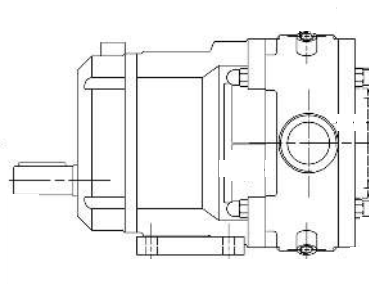

ATTENTION

The Customer, on the basis of the table in section 1.3.9 must identify the proper kind of fittings to be used to connect the hydraulic unit. Any errors can generate leaks of flushing/cooling/heating fluid not attributable to O.M.A.C. s.r.l.

To start assembly activities, the pipes used to compose the flushing/cooling/heating circuit must have fittings free to rotate at their ends in order to screw onto the flushing chamber and cooling/heating chambers.



ATTENTION

Check that the ends of the fittings are free to rotate. If they are fixed to the pipe it will no longer be possible to screw them on and one must provide new pipes of the same kind.

On the basis of the diagrams above, proceed with assembly, taking care to tighten the fittings.

Switch on the flushing unit and the cooling / heating unit that belong to the Customer in order to check there are no leaks of fluid, i.e. check the operations above have been carried out properly.



ATTENTION

The Customer must ensure that the flushing unit is always started before starting the "B series lobe displacement Pump Unit".

In case of brief or extended machine down times during the production period, in which the process fluid remains in contact with the internal parts of the pumping body (e.g. transfers of vinyl glue in industrial use), the flushing unit must remain in constant operation, to not jeopardise the operation of the pumping body sealing parts.

If one should find leaks, switch off the flushing unit and repeat the operations described above.

3.5.3 Connection to the pneumatic system

Connection to the pneumatic system assumes that the Customer provides connection to a pneumatic lubricated compressed air unit: the capacity and pressure (bar) values of this unit are indicated in the attached technical sheet.



ATTENTION

The technical sheet carries the pressure and capacity values the LDPU needs to operate properly.



ATTENTION

Before going any further, ensure to comply with the indications of section 3.3.1 of this chapter.

In order to connect the LDPU to the pneumatic distribution network in safety conditions, observe and perform the following operations in sequence:

- close the valve the LDPU will be connected to;
- connect the light blue pipes with threaded fittings to the compressed air distribution unit;
- close the connection between the pipe and unit securely;
- connect the light blue pipes with the threaded fittings to the LDPU;
- close the connection between the pipe and the LDPU securely;

- open the general valve and check the connection has been carried out properly.

3.6 Use of lubricants

The LDPU is delivered to the Customer complete with lubricant oil as per section 1.3.12. This oil is contained in the bearings box and is essential for the lubrication of bearings and motion transmission gears. Please note that the LDPU has other mechanical elements that during maintenance require lubrication. In chapter 5 there is further information regarding these operations.

3.7 Installation and pre-start check: operation test

After installation and connection to the energy sources, but before starting production, one must check the rotors rotate properly inside the pumping body, compared to the flow direction of the fluid to be handled. To do this one must:

- check all earthing connections of the LDPU have been carried out;
- power the LDPU electrically;
- open the suction valve of the Customer plant;
- open the delivery valve of the Customer plant;
- wait for a few seconds (about 15 seconds) so that the fluid fills the pumping chamber;
- move the selector from position 0, off, to position 1, on (the on warning light will light up);
- press the START button;
- with the LDPU on, check that on the manometer on the delivery pipe there is pressure inside the same pipe;
- stop the LDPU by pressing the STOP button on the electric panel supplied with the machine or in the plant of the Customer.

CHAPTER 4: USE OF THE B SERIES LDPU

The LDPU is intended to be used by operators in charge of running it; therefore:

- the operators in charge of using the LDPU must have good familiarity with this type of equipment and possess recognised technical skills acquired in at least three years of similar activities;
- the operator in charge of running the unit is directly and formally named by the Customer company management;
- the instruction described in this chapter and relative to the LDPU must be read, understood and carried out carefully by these operators in charge.



ATTENTION

Knowledge of the following instructions and the experience of the operator in charge of running the plant of the customer are essential in order to limit and reduce the risks associated with using the same production line.

4.1 Intended use

The LDPU, marketed by O.M.A.C. s.r.l., has been designed and made to be assembled in industrial plants owned by third parties, to transfer volumes of fluids, compatible with the materials used during the construction of this machine: section 1.4.1 lists the recommended operational features of the LDPU, depending on the processed fluid.

The LDPU requires compliance with all technical indications in this use and maintenance manual, which in this documentation will be indicated with the abbreviation UMM, for its proper installation.

In general, the processed fluids must meet the following specifications:

Fluid properties and range of use:

- 1) **TEMPERATURE: from -35°C to +180°C**
- 2) **VISCOSITY: Maximum 200'000cPs with forced feeding**
- 3) **HARD PARTICLE SIZE: Maximum 80% of clearance between rotors** (see sect. 1.3.4)

The LDPU has been designed and made for two types of use:

- **alimentary use;**
- **chemical use.**



WARNING

The LDPU, for alimentary use, has been made to ensure a hygienic standard equal to LEVEL 1, on the basis of UNI EN 13951.

The LDPU for alimentary use and for chemical use has been designed to transfer volumes of fluids without altering the organoleptic properties nor the physical properties.



WARNING

During its normal use, the LDPU for alimentary use and for chemical use does not alter the organoleptic characteristics nor the physical characteristics of the processed fluid.

Every LDPU comes with a technical sheet indicating the operational features in relation to the processed fluid that must be handled (name of the fluid, viscosity range, capacity range, speed range, temperature range), as declared at the time of purchase by the Customer. Section 1.3 shows a facsimile of the LDPU technical sheet. Every modification to what is indicated in the specific technical sheet or variation of the machine operating parameters must be authorised in writing by O.M.A.C. s.r.l.; the absence of such authorisation is deemed "improper use" and will void any warranty or liability under way between Manufacturer and Customer.



DANGER

Any use of the LDPU in conditions other than those indicated in "Fluid properties and range of use" and in conditions other than those indicated in the machine technical sheet is forbidden, without explicit written authorisation, issued by O.M.A.C. s.r.l.

The LDPU for alimentary use and for chemical use has NOT been designed nor built to handle pharmaceutical, explosive, etc. fluids, and in general fluids that do not comply with the indications of the specific technical sheet. In addition, the LDPU for alimentary use and chemical use has NOT been designed nor built to handle what is indicated in Regulation (EC) No. 1005/2009 of the European Parliament and the Council of 16 September, 2009, on substances that deplete the ozone layer.



ATTENTION

It is forbidden to use the LDPU for alimentary use and for chemical use to transfer the substances listed in Annex I of Regulation No. 1005/2009.

The pumping part of the LDPU is made up of the pump body, in which two rotors are housed (sect. 1.3.5 lists the types of rotors used), which rotate synchronised in the opposite direction to each other.

The pump body receives the process fluid from the suction inlet, originating from the plant of the Customer. During the operation of the LDPU, the cavities between the lobes of the rotors are filled with fluid and the counter-rotation of the rotors transfers the fluid to the delivery outlet of the pump body, channeling it in the plant where the LDPU is installed.

4.2 Controls

The LDPU can be equipped, upon request of the Customer and as an additional optional feature, with an electric control panel, where the “control actuators” are positioned for its operation.

All control, signalling and adjustment devices are marked with symbols and codes that enable to quickly understand their functions, as described below. The same devices are marked with different colours: each colour has a specific meaning.

COLOURS FOR LUMINOUS INDICATORS	MEANING
RED	DANGER / ALARM
YELLOW	ATTENTION
GREEN	SICUREZZA
WHITE	NEUTRAL
BLUE	ACCORDING TO NEEDS

CONTROLS	MEANING
RED	EMERGENCY ACTION (STOP / DISABLING)
YELLOW	INTERVAL
GREEN	START / ENABLING

Below there is the illustration of the basic composition of an electric panel:

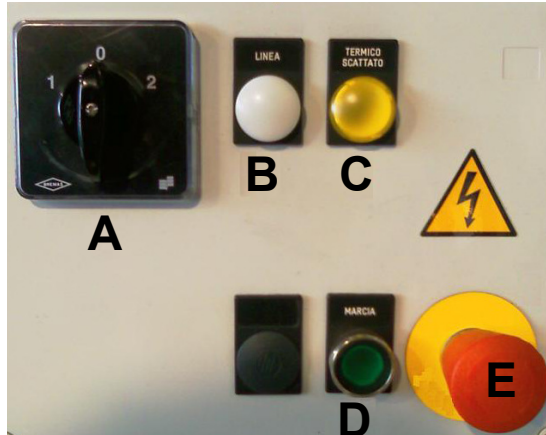

In the figure to the side one can identify:

- A** MAIN SWITCH
- B** LINE WARNING LIGHT
- C** CIRCUIT BREAKER TRIPPED WARNING LIGHT
- D** ON BUTTON + ON WARNING LIGHT
- E** EMERGENCY STOP BUTTON

The **main switch**, marked with letter **A**, is for powering or insulating the machine electric unit, position “**0**” indicates the absence of voltage, position “**1**” indicates the presence of voltage with the pump that operates with a certain rotation direction, position “**2**” indicates the presence of voltage with the pump that operates with the rotation direction opposite to that of position “**1**”.

When main switch A is in position “**1**” or in position “**2**”, one cannot open the electric panel because in this position opening is inhibited by an interblock. One can open the control panel only by putting the switch in “**0**” position.

The **indicator light**, marked with letter **B**, when on indicated that the electric panel is “under voltage”. this condition occurs only if button A is in position “**1**” or in position “**2**”.

The **emergency stop button**, marked with letter **E**, has the function to block the operation of the LDPU with immediate effect, in emergency conditions. .

However it can be used to stop operation of the LDPU even in case of normal functioning, when switch A is not present.



NOTE

The particular “mushroom” shape of the button enables easy and quick intervention of the operator, in addition a mechanical retention blocks it in pressed position.

Only after having released the button can one restore the normal operation conditions of the LDPU. One can rearm the button by slightly rotating the knob anti-clockwise.

The **on button**, marked with letter **D**, is for starting the LDPU in normal and continuous operation mode. The on and off conditions are signalled by the green light incorporated in the button: when the warning light is on it indicates that the LDPU is on, when it is switched off it indicates that it is off.

The **indicator light**, marked with letter **C**, which indicates “CIRCUIT BREAKER TRIPPED”, lights up for an operation anomaly of the LDPU, the electric motor is in overload. To reset normal operation conditions one must restore the “circuit breaker” as specified in the use and maintenance instructions of the electrical supply.

The electric control panel can be equipped with an **inverter**, as an additional optional feature: it can be identified, in the figure below, with letter **G**, which indicates the operation warning light, and with letter **F**, which indicates **speed adjustment potentiometer**, which is needed to set the electric power supply voltage manually.

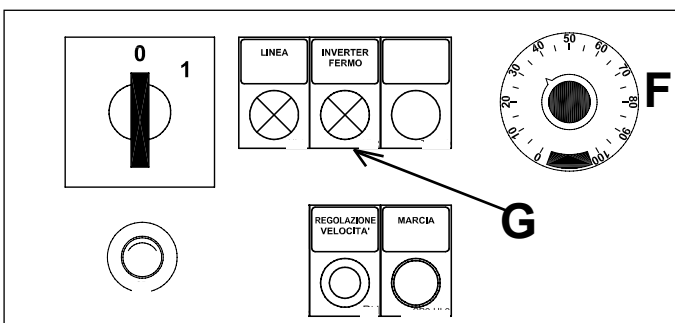

An inverter is in fact an electronic device able to vary the rotation speed of electric motors, which is directly associated with the supply voltage frequency.

Section 4.2.1.1 shows a simple mathematical formula for calculating the power supply frequency, knowing the number of output revolutions of the control unit.

4.3 LDPU volumetric capacity adjustment methods

On the basis of the production needs of the Customer, one can adjust the power supplied by the LDPU. The adjustment of the volumetric capacity of the LDPU can be carried out in two ways:

- acting on the inverter adjustment, if the LDPU is equipped with an inverter;
- acting on the speed controller hand-wheel adjustment, if the LDPU is equipped with a mechanical speed controller.

4.3.1 Adjustment of the volumetric capacity with the inverter

This operation, i.e. the variation of the electric motor speed via inverter, must be carried out by the operator in charge of running the plant: he must rotate the speed adjustment potentiometer knob on the electric panel, setting it on the desired frequency value, expressed in Hz.

The result of the frequency adjustment, with the potentiometer, translates in a speed variation of the electric motor revolutions and consequently in a capacity variation of the LDPU.

The operator must read the consequent volumetric capacity variation on the meter placed on the delivery piping near the LDPU (see stage 2 section 3.3.3).

Frequency calculation.

It is assumed one has an electric motor that supplies a current number of output revolutions, $N_{current}$ at the national electric network frequency, equal to 50 [Hz] and that we will indicate more in general with $F_{current}$. Assuming one wants to obtain a different number of output revolutions N_{new} the frequency with which the inverter must be set, f_{new} will be equal to: $f_{new} = (F_{current} * N_{new}) / N_{current}$

4.3.2 Adjustment of volumetric capacity via mechanical speed controller

This operation, i.e. the speed variation of the speed controller, must be carried out by the operator in charge of running the plant: he must act on the mechanical speed controller hand-wheel, only after having started the LDPU.



WARNING

Adjust the mechanical speed controller hand-wheel, only after having started the LDPU. The adjustment of the speed controller must not be carried out with the machine off as it can cause the breakage and malfunctioning of the speed controller.

Before adjusting the hand-wheel, read the value the speed controller is set on, in the hand-wheel panel. The hand-wheel panel is shown in figure A. Below, in the table placed to the side as an example, one can obtain the value of the LDPU revolutions.

For example, if we are in presence of a size "10" speed controller and the hand-wheel (figure A) has the arrow on 5, simply trace a vertical line, starting from the column corresponding to the "10" size, until 5, indicated by the hand-wheel, to then proceed horizontally, towards the left until reading the corresponding number of revolutions at which the speed controller operates, i.e. 450 RPM.

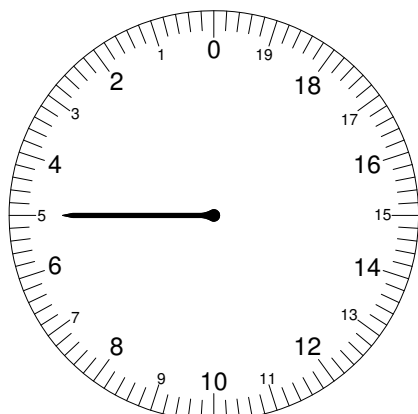
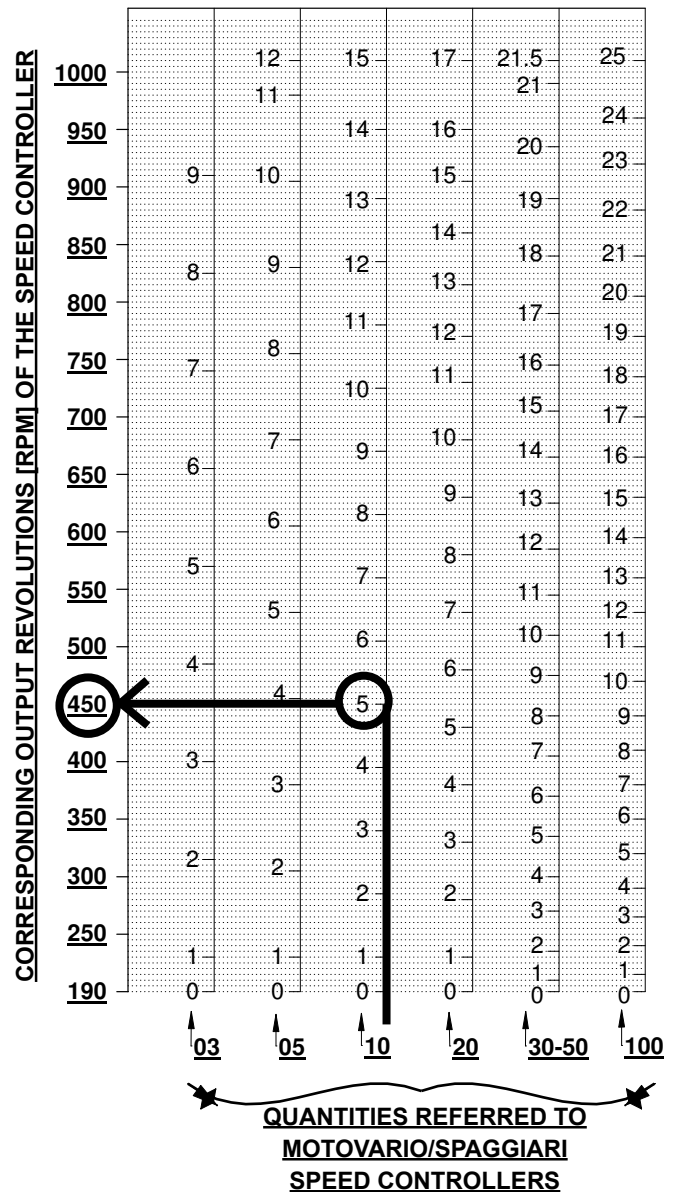

figure A



4.4 Work cycle description

The LDPU, whose functional element is the "B series lobe displacement pump", is equipped with a control unit that, depending on the version, can be fitted with a speed controller, a gear motor, an electric motor, a pneumatic motor or a hydraulic motor, with or without electric panel.

The capacity adjustment is achieved by increasing or decreasing the number of revolutions of the "B series lobe displacement pump", intervening directly on the revolutions output of the motor mentioned above or acting on the actuators on the control panel (inverter), if fitted.

The LDPU is reversible: full performance can be achieved in both rotation directions of the pump rotors (section 1.3.5 lists the types of rotors used).

The pumping action of the "B series lobe displacement pump" is achieved thanks to the counter-rotation of two rotors (letter "C" indicated in the figure in section 1.2, indicating one of the two rotors), housed inside the pumping chamber (letter "U" indicated in the figure in section 1.2 or see figure below). The rotors are assembled on rotating shafts supported by bearings (letters "G" and "H" shown in the figure in section 1.2), which are housed in the external gearbox (letter "S" shown in the figure in section 1.2). Via a couple of sprocket wheels (letters "N" and "P" indicated in the figure in section 1.2) one transfers motion from a drive shaft (letter "M" indicated in the figure in section 1.2) to a driven shaft (letter "R" indicated in the figure in section 1.2). The synchronism of the rotors is such that they rotate without coming into contact with each other: in this conditions "the rotors are in phase".

When the lobes of the rotors move away from each other, the volume between them increases, creating a decrease in pressure near the suction outlet: this enables a certain volume of fluid to enter (value of fluid transported identified in the table in section 1.3.1, in the "theoretical capacity" column, depending on the pump model size) into the pumping body. The fluid is transported along the internal of the pumping chamber, from the suction inlet to the delivery outlet of the pump body. When the volume of fluid, trapped between the lobes and the external perimeter of the pumping chamber, reaches in proximity of the delivery outlet, the counter-rotation of the two rotors creates a sudden decrease of available volume and a consequent increase in pressure that pushes the fluid out of the pumping body, by channelling it into the plant where the LDPU is installed.

4.5 Cycle start instructions

The start of the LDPU work cycle is supervised and activated by the operator in charge of running the plant, after having carried out the following preliminary checks.

4.5.1 Preliminary operations: check list

Before commissioning the "B series lobe displacement Pump Unit" check the following:

- if the LDPU has suffered damages, contact the O.M.A.C. s.r.l. Technical Office immediately as described in chapter 2;
- make sure that all the bolted connections are tightened properly and that the installation of the LDPU has been carried out properly in accordance with the requirements of this use and maintenance manual;
- ensure continuity of the equipotential protection circuit and that it is connected, as per section 3.5.1.1 of this use and maintenance manual;
- ensure that all hydraulic connections, where required by the configuration of the LDPU, are carried out properly, as described in chapter 3;
- make sure, as a preventive measure, that there is lubricant oil, visible via the oil level cap placed on the side of the pump gear box, part of the LDPU: please bear in mind that all pumps fitted in the LDPU are already supplied with the proper amount of lubricant oil.



DANGER

Incorrect lubrication or lubrication with lubricant products incompatible with the materials used in the construction and completion of the LDPU can lead to premature wear or breakage of the sealing elements or other parts in contact with the process fluid.



ATTENTION

O.M.A.C. s.r.l. is not liable for any damage caused by improper use of lubricants incompatible with the materials used in the construction and completion of LDPU or with the process fluid:

- ensure that the power supply voltage of the LDPU is that required as shown on the electric motor data plate or electric panel; it is reminded that the electric connection must be carried out by skilled personnel and compliant with the electric motor data plate, both for the connection of the terminal board and for the thermal calibration in accordance with the maximum admitted absorption;
- ensure that the pipes have been washed with clean water, to remove foreign bodies, cinders, dust or scraps from processes carried out on the plant;
- with reference to chapter 3 ensure that a CIP/SIP cleaning and/or sanitisation cycle has been carried out, as per section 3.4;
- if there is a mechanical safety valve on the front cover or a bridge one on the external cover of the LDPU, check that the spring has been adjusted, as indicated in section 3.3.3;
- if there is a pneumatic safety valve on the front cover of the LDPU, check that the auxiliary pneumatic unit pressure has been adjusted, as indicated in section 3.3.3;
- make sure that all gates in suction and delivery are completely open, in order to ensure the suction pipes are full of process fluid;



ATTENTION

The LDPU must not be used to process fluids other than that / those for which it has been selected and sold, with reference to the intended use. In case of doubt, contact the O.M.A.C. s.r.l. Technical Office. Fluids incompatible with the materials used in the construction and completion of the LDPU can damage the same Unit, other parts of the unit and cause injuries and damages to the operators in charge of running the plant.



4.5.2 First start-up



ATTENTION

The B series lobe displacement pump part of the LDPU can also operate when empty because the moving parts are not in contact with each other, except for the sliding faces of the seals that, especially at high speeds, tend to overheat. For this reason, it is recommended to never let the B Series lobe displacement pump operate dry for long periods so not to cause premature wear of the sealing parts.

The allowed dry operation period depends on the rotation speed and materials of the sliding faces of the seals but, in any case, it is recommended not to exceed 5-10 minutes for soft materials and 10-15 seconds for hard carbides.

- start the LDPU possibly on reduced speed to then increase up to working speed, checking any anomalies (pump over-pressure, piping leaks, cavitation, vibration, etc.);
- if the working speed is very high it is normal for the temperature of the pump gear box to reach 50°C - 60°C, especially in the first hours of operation;

4.6 Stopping instructions

When the LDPU stops one must intervene on the electric control panel, present on the machine or on the plant of the Customer, and intervene on:

- emergency stop, if a situation of danger is occurring;
- general selector, for a machine stop.

Once one of the two buttons has been pressed, one must:

- disconnect power and block the power device so that the LDPU cannot be operated;
- close the valves placed on the suction and discharge side;
- de-pressurise, if present on the LDPU, the pneumatic safety valve on the front cover;
- empty and de-pressurise the pump and suction and delivery piping system connected to the LDPU;



DANGER

If the process fluid is very hot, or in any case above room temperature, one must let the LDPU cool down, with particular reference to the pump and parts in direct contact with the process fluid, until reaching room temperature.

- carefully read Chapter 5 relating to assembly and disassembly of the LDPU, before carrying out any maintenance or inspection operation of the LDPU;
- clean the outside of the pump before disassembly, as per section 3.4.1.1.

4.7 Instructions for restarting after a stop

In order to restart the LDPU one must:

- open the valves placed on the suction and discharge side;
- pressurise, if present on the LDPU, the pneumatic safety valve on the front cover;
- intervene on the electric control panel, present on the machine or plant of the Customer, and:
 - move the selector from position "0" to position "1" or "2", according to the rotation direction;
 - press the START button.

4.8 Switch-off

To switch off the LDPU one must press the STOP key on the electric control panel present on the machine or on the plant of the Customer.

4.9 Emptying

To empty the LDPU, after machine down time, one must operate in the machine as described below:

- stop the plant, as described in section 4.6;
- use a hex spanner to remove the screws of the front the front cover and move the cover away from the pumping chamber;
- let the remaining fluid drain into a container to dispose of it according to the existing regulatory framework.

Once the excess fluid has drained from the pump body, fully remove the cover and continue with the required operations (maintenance, parts replacement, dismantling, etc.).

4.10 Residual risks

Listed below are the main residual risks that may occur in the "B series lobe displacement Pump Unit", deriving from the incorrect execution of one of the operations described in this manual.

CAUSES THAT MAY GENERATE RESIDUAL RISKS	RESIDUAL RISKS
Removal of the front cover / Emptying / Leakage of fluid	Contact with dangerous process fluid
Incorrect earthing	Electric shock
Breakage of piping / Breakage of mechanical components	Ejection of process fluid
Incorrect or incomplete fixing of the pump Unit / Incorrect tightening of screws	Support vibrations and movements / Misalignment between pump Unit and piping of Customer plant
Incorrect calculation of performances (capacity, pressure, speed)	Rotors seizure, possible piping breakage
Incorrect closure of a valve upstream or downstream of the pump Unit	Water hammer with projection of cover
Presence of metallic cinders in the plant of the Customer	Possible seizure of rotors
Incorrect CIP/SIP	Contamination of process fluid
Leakage from sealing parts	Ejection of process fluid

4.11 Dangers generated by use

Incorrect use of the LDPU, generated by failure to comply in full or in part with the use and maintenance instructions contained in this UMM, can cause technical dangers in the operation of the Customer plant.

Listed below are the incorrect ways to use the LDPU.

INCORRECT USE	ARISING DANGERS
Use of the LDPU for transfers of fluid in different conditions of hygienic level than those for which it has been of its organoleptic designed(*)	Contamination of process fluid or degradation of the organoleptic specifications
Incorrect execution of CIP/SIP	Possible contamination of process fluid
Failure to use personal protection equipment	Danger for health of operators in charge of using the plant of the Customer
Failure to comply with the procedures described in chapters 3 and 4 of this manual	Malfunctioning of the plant of the Customer / Risks for the health of operators

(*) The "B series lobe displacement Pump Unit" for alimentary use has been designed to ensure hygiene Level 1, in accordance with EN 14159.

4.12 Prohibited use

The unintended uses of the "B series lobe displacement Pump Unit" for chemical use or alimentary use are all those that are NOT covered under sections 1.4 and section 4.1.



ATTENTION

O.M.A.C. s.r.l. forbids any use not expressly indicated in this UMM and is not liable for any damage caused by unauthorised improper use of the LDPU or with the process fluid.

4.13 Management of emergency situations

In the event of an emergency situation connected directly or indirectly to the LDPU, one must stop machine operation, intervening on the electric control panel, present on the machine or plant of the Customer.

One can stop operation by pressing the emergency button, marked with letter "E" in section 4.2 of this chapter (red mushroom button on circular yellow base).

CHAPTER 5: B SERIES LDPU MAINTENANCE

Where provided, the contents of this chapter is specifically addressed to the internal company **maintenance operator**. This person, named directly and formally by the Customer company management; has at least two years experience in this role and has the required technical abilities for operating in safety conditions and interpret the technical indications contained in the above mentioned documentation properly.



DANGER

Before disconnecting the LDPU from its energy supplies, make sure that the plant or part of it is contained in complies with the following conditions:

- absence of product and eventually washing;
- absence of residual pressure;
- temperature of contact surfaces not dangerous.

Before carrying out any maintenance operation on the LDPU pump, ensure one has carried out the pump and plant stopping operations, described in section 4.5 "Use of the line: stopping instructions"

During the LDPU assembly and disassembly operations, as during its routine and extraordinary maintenance, one must wear the personal protection equipment, according to the operation and risk connected to the activity performed by the appointed operator, as described in section 1.9.

5.1 Troubleshooting and solving problems

<i>FAILURE: HIGH POWER ABSORPTION BY GPVL</i>	
<i>POSSIBLE CAUSES:</i>	<i>REMEDIES:</i>
Excessive medium viscosity	Decrease the speed of the pump, increase the temperature of the medium
Low medium temperature	Increase the temperature of the medium, heat the pumping case (within the limits given by the manufacturer)
Excessive back-pressure	Remove possible obstructions in the outlet piping, increase the piping diameter, reduce its length and the number of the bends
Too tight packing gland	Loosen the packing gland and tighten it rightly (see instructions)
Excessive pump speed	Decrease the speed of the pump
Piping press on pumping case	Check the piping alignment, if necessary fit flexible expansion joints, and fix the piping on the plant structure
Not aligned joint	Check the alignment between pump and drive device
Worn out bearings	Replace the bearings by the manufacturer
Worn out or untimed gears	Replace the gears or time them according to the instructions
Wrong quantity / quality of gears oil	Act according to the manufacturer's instructions
Parts in contact in the pumping case	Check the design pressure coincides with the operating pressure
Worn out rotors	Replace rotors

<i>FAILURE: GPVL JUST STARTING BLOCK</i>	
<i>POSSIBLE CAUSES:</i>	<i>REMEDIES:</i>
Excessive medium viscosity	decrease the speed of the pump, increase the temperature of the medium
Low media temperature	increase the temperature of the medium, heat the pumping case (within the limits given by the manufacturer)
Excessive back-pressure	Remove possible obstructions in the outlet piping, increase the piping diameter, reduce its length and the number of the bends
Worn out or untimed gears	replace the gears or time them according to the instructions
Parts in contact in the pumping case	Check the design pressure coincides with the operating pressure

<i>FAILURE: UNPRIMED OF THE PUMP</i>	
<i>POSSIBLE CAUSES:</i>	<i>REMEDIES:</i>
Insufficient N.P.S.H (Net Positive Suction Head)	Increase the head, the piping inlet diameter, reduce the suction piping length and the number of the bends, decrease the speed of the pump and the temperature of the medium, check that the increase (caused by the decreasing temperature) is suitable to the motor power
Medium evaporates in inlet	Increase the head, the piping inlet diameter, reduce the suction piping length and the number of the bends, decrease the speed of the pump and the temperature of the medium, check that the increase (caused by the decreasing temperature) is suitable to the motor power
Air enters in inlet	Check and tighten suction piping connections, tighten the packing glands and, if necessary, replace them
Presence of air in the suction	Fill pumping case and feeding piping with liquid, expelling air
Not enough liquid level in the tank in the suction	Increase medium level, lower suction opening position
Dirty or blocked valve or suction filter	Clean filters

<i>FAILURE: UNPRIMED OF THE PUMP (follow)</i>	
<u>POSSIBLE CAUSES:</u>	<u>REMEDIES:</u>
Excessive medium viscosity	Decrease the speed of the pump, increase the temperature of the medium
Too loose packing gland	Tighten the packing gland rightly (see instructions)
Excessive pump speed	Decrease the speed of the pump

<i>FAILURE: SEIZURE OF THE PUMP</i>	
<u>POSSIBLE CAUSES:</u>	<u>REMEDIES:</u>
Excessive medium temperature	Decrease the temperature of the medium, cool the pumping case
Presence of suspended particles in the medium	Clean suction piping and install a filter on it
Excessive back-pressure	Remove possible obstructions in the outlet piping, increase the piping diameter, reduce its length and the number of the bends
Too tight packing gland	Loosen the packing gland and tighten it rightly (see instructions)
Piping press on pumping case	Check the piping alignment, if necessary fit flexible expansion joints, and fix the piping on the plant structure
Worn out bearings	Replace the bearings by the manufacturer
Worn out or untimed gears	Replace the gears or time them according to the instructions
Wrong quantity / quality of gears oil	Act according to the manufacturer's instructions
Parts in contact in the pumping case	Check the design pressure coincides with the operating pressure

<i>FAILURE: NO FLOW-RATE</i>	
<u>POSSIBLE CAUSES:</u>	<u>REMEDIES:</u>
Wrong rotation direction	Invert the rotation direction
Unprimed pump	Fill pumping case and feeding piping with liquid, expelling air
Insufficient N.P.S.H (Net Positive Suction Head)	Increase the head, the piping inlet diameter, reduce the suction piping length and the number of the bends, decrease the speed of the pump and the temperature of the medium, check that the increase (caused by the decreasing temperature) is suitable to the motor power
Presence of air in the suction	Increase medium level, lower suction opening position
Dirty or blocked valve or suction filter	Clean filters
The relief valve leaks	Check the relief valve setting, clean sealing parts, substitute worn parts

<i>FAILURE: LDPU LOW FLOW-RATE</i>	
<u>POSSIBLE CAUSES:</u>	<u>REMEDIES:</u>
Insufficient N.P.S.H (Net Positive Suction Head)	Increase the head, the piping inlet diameter, reduce the suction piping length and the number of the bends, decrease the speed of the pump and the temperature of the medium, check that the increase (caused by the decreasing temperature) is suitable to the motor power
Medium evaporates in inlet	Increase the head, the piping inlet diameter, reduce the suction piping length and the number of the bends, decrease the speed of the pump and the temperature of the medium, check that the increase (caused by the decreasing temperature) is suitable to the motor power
Air enters in inlet	Check and tighten suction piping connections, tighten the packing glands and, if necessary, replace them
Presence of air in the suction	Fill pumping case and feeding piping with liquid, expelling air
Not enough liquid level in the tank in the suction	Increase medium level, lower suction opening position
Dirty or blocked valve or suction filter	Clean filters
Insufficient medium viscosity	Increase pump speed, decrease the temperature of the medium
Excessive medium temperature	Decrease the temperature of the medium, cool the pumping case
Excessive back-pressure	Remove possible obstructions in the outlet piping, increase the piping diameter, reduce its length and the number of the bends
Too loose packing gland	Tighten the packing gland rightly (see instructions)
Insufficient pump speed	Increase pump speed
Transmission belt slips	Stretch the belt
Worn out rotors	Replace rotors
The relief valve leaks	Check the relief valve setting, clean sealing parts, substitute worn parts
The relief valve is wrongly set	Check the relief valve setting and the spring compression in the way that the spring will open at a 10% more of the operating pressure
The relief valve vibrates	Check the relief valve setting, check and clean the valve

<i>FAILURE: PORTATA IRREGOLARE</i>	
<u>POSSIBLE CAUSES:</u>	<u>REMEDIES:</u>
Insufficient N.P.S.H (Net Positive Suction Head)	Increase the head, the piping inlet diameter, reduce the suction piping length and the number of the bends, decrease the speed of the pump and the temperature of the medium, check that the increase (caused by the decreasing temperature) is suitable to the motor power
Medium evaporates in inlet	Increase the head, the piping inlet diameter, reduce the suction piping length and the number of the bends, decrease the speed of the pump and the temperature of the medium, check that the increase (caused by the decreasing temperature) is suitable to the motor power
Air enters in inlet	Check and tighten suction piping connections, tighten the packing glands and, if necessary, replace them
Presence of air in the suction	Fill pumping case and feeding piping with liquid, expelling air
Not enough liquid level in the tank in the suction	Increase medium level, lower suction opening position
Dirty or blocked valve or suction filter	Clean filters
Too loose packing gland	Tighten the packing gland rightly (see instructions)
Excessive pump speed	Decrease the speed of the pump

<i>FAILURE: NOISE PUMP AND LDPV VIBRATION</i>	
<u>POSSIBLE CAUSES:</u>	<u>REMEDIES:</u>
Insufficient N.P.S.H (Net Positive Suction Head)	Increase the head, the piping inlet diameter, reduce the suction piping length and the number of the bends, decrease the speed of the pump and the temperature of the medium, check that the increase (caused by the decreasing temperature) is suitable to the motor power
Medium evaporates in inlet	Increase the head, the piping inlet diameter, reduce the suction piping length and the number of the bends, decrease the speed of the pump and the temperature of the medium, check that the increase (caused by the decreasing temperature) is suitable to the motor power
Air enters in inlet	Check and tighten suction piping connections, tighten the packing glands and, if necessary, replace them
Presence of air in the suction	Fill pumping case and feeding piping with liquid, expelling air
Not enough liquid level in the tank in the suction	Increase medium level, lower suction opening position
Dirty or blocked valve or suction filter	Clean filters
Excessive medium viscosity	Decrease the speed of the pump, increase the temperature of the medium
Excessive medium temperature	Decrease the temperature of the medium, cool the pumping case
Presence of suspended particles in the medium	Pulire la tubazione di alimentazione, installare un filtro di alimentazione
Too loose packing gland	Tighten the packing gland rightly (see instructions)
Excessive pump speed	Decrease the speed of the pump
Piping press on pumping case	Check the piping alignment, if necessary fit flexible expansion joints, and fix the piping on the plant structure
Not aligned joint	Check the alignment between pump and drive device
Pump or drive device not fixed on the base	Tighten bolts and re-check the alignment between pump, device and joint
Worn out bearings	Replace the bearings by the manufacturer
Worn out or untimed gears	Replace the gears or time them according to the instructions
Wrong quantity / quality of gears oil	Act according to the manufacturer's instructions
Parts in contact in the pumping case	Check the design pressure coincides with the operating pressure
The relief valve vibrates	Controllare la regolazione della valvola, ispezionare e pulire la valvola
The relief valve is wrongly set	Check the relief valve setting and the spring compression in the way that the spring will open at a 10% more of the operating pressure

<i>FAILURE: OVERHEATING OF THE PUMP</i>	
<u>POSSIBLE CAUSES:</u>	<u>REMEDIES:</u>
Excessive medium viscosity	Decrease the speed of the pump, increase the temperature of the medium
Excessive medium temperature	Decrease the temperature of the medium, cool the pumping case
Excessive back-pressure	Remove possible obstructions in the outlet piping, increase the piping diameter, reduce its length and the number of the bends
Too tight packing gland	Loosen the packing gland and tighten it rightly (see instructions)
Piping press on pumping case	Check the piping alignment, if necessary fit flexible expansion joints, and fix the piping on the plant structure
Not aligned joint	Check the alignment between pump and drive device
Worn out bearings	Replace the bearings by the manufacturer
Worn out or untimed gears	Replace the gears or time them according to the instructions
Wrong quantity / quality of gears oil	Act according to the manufacturer's instructions

<i>FAILURE: OVERHEATING OF THE PUMP (follow)</i>	
<i>POSSIBLE CAUSES:</i>	<i>REMEDIES:</i>
Parts in contact in the pumping case	Check the design pressure coincides with the operating pressure
The relief valve leaks	Check the relief valve setting, clean sealing parts, substitute worn parts

<i>FAILURE: OVERHEATING OF THE MOTORIZATION</i>	
<i>POSSIBLE CAUSES:</i>	<i>REMEDIES:</i>
Low medium temperature	Increase the temperature of the medium, heat the pumping case (within the limits given by the manufacturer)
Excessive medium viscosity	Decrease the speed of the pump, increase the temperature of the medium
Excessive back-pressure	Remove possible obstructions in the outlet piping, increase the piping diameter, reduce its length and the number of the bends
Too tight packing gland	Loosen the packing gland and tighten it rightly (see instructions)
Excessive pump speed	Decrease the speed of the pump
Piping press on pumping case	Check the piping alignment, if necessary fit flexible expansion joints, and fix the piping on the plant structure
Not aligned joint	Check the alignment between pump and drive device
Worn out bearings	Replace the bearings by the manufacturer
Worn out or untimed gears	Replace the gears or time them according to the instructions
Wrong quantity / quality of gears oil	Act according to the manufacturer's instructions
Parts in contact in the pumping case	Check the design pressure coincides with the operating pressure
Worn out rotors	Replace rotors

<i>FAILURE: FAST ROTORS WEAR</i>	
<i>POSSIBLE CAUSES:</i>	<i>REMEDIES:</i>
Excessive medium temperature	Decrease the temperature of the medium, cool the pumping case
Presence of suspended particles in the medium	Clean suction piping and install a filter on it
Excessive back-pressure	Remove possible obstructions in the outlet piping, increase the piping diameter, reduce its length and the number of the bends
Piping press on pumping case	Check the piping alignment, if necessary fit flexible expansion joints, and fix the piping on the plant structure
Worn out bearings	Replace the bearings by the manufacturer
Worn out or untimed gears	Replace the gears or time them according to the instructions
Parts in contact in the pumping case	Check the design pressure coincides with the operating pressure

<i>FAILURE: FAST SEALS WEAR</i>	
<i>POSSIBLE CAUSES:</i>	<i>REMEDIES:</i>
Presence of suspended particles in the medium	Clean suction piping and install a filter on it
Too tight packing gland	Loosen the packing gland and tighten it rightly (see instructions)
Insufficient flushing seal liquid level	Check the flushing seal liquid and, if necessary, increase its flow-rate

5.2 Instruction for carrying out checks

Before any maintenance intervention one must provide all the security measures that comply with the accident prevention regulations in force. In particular inhibit operation of all electric utilities and discharge any residual energy.

The instruments and tools needed for good maintenance are those normally supplied as standard to a technician with assembly/maintenance tasks.

In the case the machine is positioned above ground level it is up to the Customer to make the machine accessible to the operator in order to permit adjustment, maintenance, repair, etc. operations possible, in safety conditions.

- In the case the process fluid is subject to easy drying, crystallisation or sedimentation, it is essential to wash the pump and pipes at the end of each operation, i.e. at the beginning of extended machine down time.
- The reversibility of the rotation direction, common feature of all OMAC pumps, offers the possibility to recall the process fluid, completely emptying the delivery pipes and putting the product in storage.
- If the LDPU is not use for a long period of time, when starting check that the sealing parts are not blocked by turning the pump shaft manually.
- If the process fluid is subject to freezing or solidification, ensure before starting, that the pipes and the pump body are not obstructed by solid parts of fluid, formed during inactivity.
- The references below, with position number, are intended as the exploded view drawing of the B series lobe displacement pump indicated in section 1.3.



5.2.1 Daily checks

- Visual inspection of all sealing parts and of the general operation of the LDPU.
- If one experiences a loss of mechanical seals, see to replace them as soon as possible, to prevent the process fluid from entering the bearings box or stagnating on the ground.

5.2.2 Weekly checks

- Check the oil level of the pump and motor unit, eventually top-up with oil of the kind indicated by the manufacturers, after having checked the proper amount and the degree of viscosity on the respective use and maintenance manuals.
- Inspect the pumping chamber and free it from any scaling due to the kind of process fluid.
- Check that there is no seizing between the rotors and the static surfaces of the pumping body.
- Check that the mechanical safety valve on the cover, when provided, is not blocked by a long period of inactivity. To check simply remove the adjustment screw completely (pos.59 page 29) and then adjust the calibrations of the spring again.

5.2.3 Six monthly checks

- If the LDPU works constantly at high temperatures, above 120°C, check the integrity of the pump lubricant oil; if it has gone dark in colour, see to its replacement. The same goes for the motorisation unit; keep to the instructions of the manufacturer.
- Check that the distribution gears have not reached such a play to enable the rotors to come into contact; in this case replace the worn gears.
- Check the stiffness of the shafts: if there is even minimal axial or radial play, see to the replacement of the bearings.
- Check the corrosion condition of the bearings box; if needed re-paint with suitable paint and protect it from premature wear. The "B series lobe displacement pump" is painted as standard with EPOXY ENAMEL GLOSS RAL 7032.



NOTE

By systematically following these checks, the pump will maintain its original performances unchanged for many years.

5.3 Periodic checks of the safety and emergency devices

When the LDPU is fitted with an electric control panel, one must carry out weekly checks for the correct operation of the actuators and operation of the relative warning lights.

5.4 Indication of dangerous temperatures

In the event of pumps predisposed for pumping products at high temperatures up to 150°C, there is a signal placed on the same pump that warns the operators of the presence of high temperature surfaces, as shown in figure C:



5.5 Oils present

- Check the oil level placed on the side of the pump daily; it must always be completely full when the pump is switched off.
- If needed, restore the level by adding oil with reference to section 1.3.12 of this UMM, relating to the degree of viscosity and the proper amount, expressed in litres, for every LDPU size.
- If the pump is used with vertical openings, check the proper position of the vent cap and level and if needed invert them.
- Oil replacement must take place after a run-in period of about 150 working hours, subsequently every 2500 hours.
- If the gear box works constantly at temperatures above 90°C, lubricate with oil with a higher degree of viscosity (see section 1.3.12) and replace it every 1000 working hours.

5.6 Tests and checks

Listed below are the checks to be performed, at predetermined intervals, on the LDPU.

5.6.1 Lubrication

The LDPU has other mechanical elements that during maintenance require lubrication: these components are the sealing parts.

In assembly and disassembly operations there are the specifications relating to the surfaces to be lubricated with grease and the stages in which this operation must be carried out.

5.6.2 Single mechanical seals

- Mechanical seals do not require any maintenance.
- When there is a leak, caused by wear and contact surfaces, see to replace the whole seals (see disassembly instructions).
- In case of extended operation with worn seals, check that some process fluid leaks outside the pumping body.

IMPORTANT: it is recommended to not let the mechanical seals turn when dry.

5.6.3 Mechanical seals with flushing

- Flushed mechanical seals, as simple mechanical seals, do not require any maintenance;
- When one replaces the mechanical seal, also replace the rotating ring (pos. 224) and the lip ring (pos. 223) of the auxiliary seal.
- With flushing connected adequately, the pump can operate even in absence of the product to be pumped, because the seals do not risk over-heating;
- Check that flushing is always efficient, when the pump is operating, in order not to damage the auxiliary seals (connection diagram section 3.5.2);
- To disassemble the flushed mechanical seals, follow the instructions of the simple mechanical seals, described in this chapter;
- To remove the fixed part of the mechanical seal, disassemble the chamber (pos. 22) from the pumping body;
- When assembling, before inserting the rotating part of the mechanical seal on the shaft, position the rotating ring properly (pos. 224) and fit the auxiliary sealing ring adequately (pos. 223) in its housing on the chamber (pos. 220), as per the section drawings in chapter 7, in the sections relative to the sealing parts.

The purpose of flushing mechanical seals is generally to cool down and lubricate the sliding faces of the mechanical seal, via forced circulation of a flushing liquid.

The flushing liquid and its distribution circuit must be provided by the Customer. **The Customer must also check, through his Technical Office, the compatibility between the flushing liquid and the process fluid, as well as the compatibility between the flushing liquid and the components of the “B series lobe displacement Pump Unit” in close contact (pumping chamber material, seals material, working temperature, etc.)**

Once this requirement has been checked and validated, the Technical Office of the Customer will see to expressly authorise the operator responsible for the installation of the LDPU to fit the flushing circuit on the seals flushing chamber and commission it, before starting the LDPU for the first time.



ATTENTION

The operator responsible for fitting the flushing circuit must be expressly authorised by the Technical Office of the Customer to connect the same flushing circuit to a system that uses “flushing liquid” compatible with the process fluid.

O.M.A.C. s.r.l. is not responsible for improper use of the flushing liquid nor for damages deriving from contamination of the process fluid.



DANGER

Improper use of the flushing system can cause breakage of the mechanical seals with consequent damage of the LDPU and contamination of the process fluid.

O.M.A.C. s.r.l. is not responsible for improper use of the flushing system.

The operator designated by the Customer must connect the flushing circuit joints to the input and output holes of the seals flushing chambers and adjust the temperature and pressure according to the type of seal fitted on the displacement pump, as described below:

- in case of single mechanical seals the flushing pressure must be about 1.5 - 2 bar with 0.5 - 1 lt of flow-rate;
- in the case of double mechanical seals the flushing pressure must be equal to the working pressure or higher by 1 bar, to ensure that the film created between the sliding faces of the seals is made up of the flushing liquid and not by the process fluid, which according to its chemical composition may crystallise and solidify after machine down time and generate, upon restarting the unit, a “sticking” phenomenon of the faces, causing their breakage.

The flushing temperature must be established according to the type of processed fluid and to the flushing utility: generally using liquid at room temperature - about 15° - 20° - is necessary to disperse the heat generated by friction of the seals faces, or vice-versa, using liquid at higher temperatures, for example 80° - 90°, can be useful for melting, removing, cleaning and lubricating the seals faces.

The dimensions of the inlet and outlet holes joints of the flushing circuit are listed in the table in section 1.3.9 in chapter 1.

5.6.4 Mechanical seals balancing

All mechanical seals fitted on the B series lobe displacement pumps are equipped with a balancing ring of the fixed parts, to cope with severe operating conditions such as:

- pressure peaks due to the first break-away or start-ups under load;
- particularly viscous or sticky product;
- frequent start-ups.

IMPORTANT: the balancing ring must not strain on the fixed part of the seal; check that there is slight play (about 0.05/0.3 mm).

5.6.5 Packing seals

- The tightening of packing seals is carried out when the pump is tested;
- After a few hours of operation there is an adjustment of the packing, consequently one must adjust it further, being careful to leave slight dripping that enables lubrication of the sealing rings.
- When the dripping leakages are excessive and one cannot tighten any further, replace the packing and shaft protection sleeve.

5.7 Disassembly and assembly operations of B100 size pump.

This section lists the disassembly / assembly operations of the B100 size lobe pump.

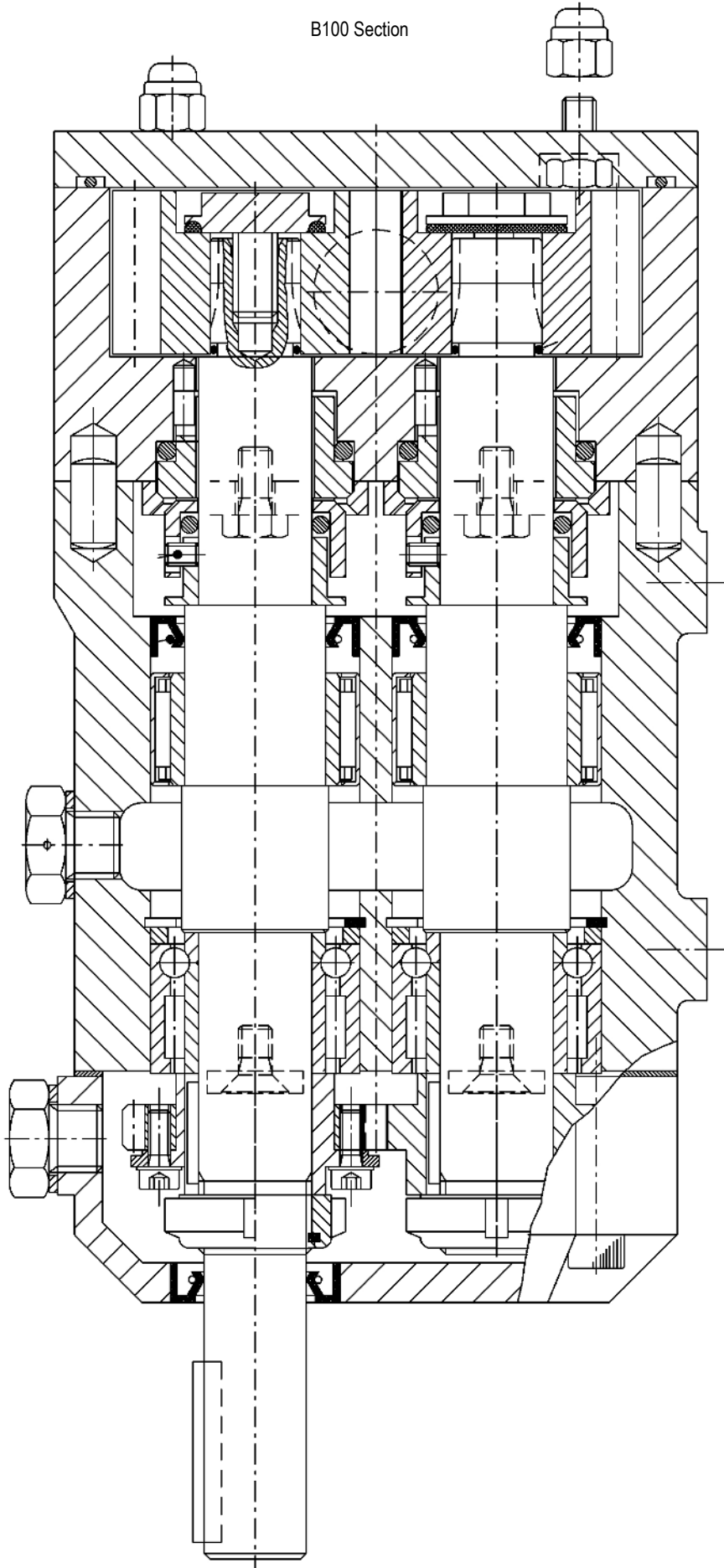

5.7.1 Disassembly of the pumping body

Before removing the cover, ensure that the pump and motor are insulated, that the pump is cold enough to be touched safely, that all fluids have been discharged and make sure that the pump body is insulated and de-pressurised. If the end cover is fitted with a by-pass valve consult the relative section. Then proceed as follows:

1 Remove the front nuts and exert leverage in the provided slots on cover

2 Unscrew anticlockwise the rotor nuts, interposing a non metal element between the rotors, making them stop rolling

3 Take care of the reference marked on rotors and shafts (1-2) so that you will set them rightly while reassembling

4 Extract the rotors, taking care you don't damage them by means of metal tools

5 extract the rotor case

6 Extract the rotating part of the mechanical seal from the shaft, after disassembling the bearing retainers

7 Untighten the socket head screws on mechanical seal

8 Extract the rotating part of the mechanical seal from the shaft

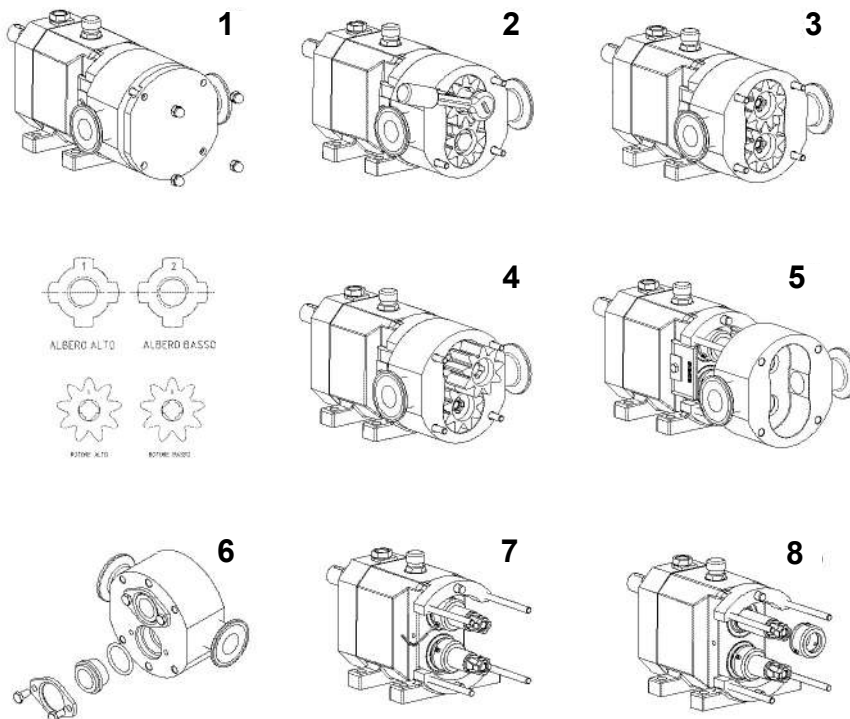

5.7.2 Assembly of the pumping body



ATTENZIONE

9 During the following operations, take care you don't damage the lapped seal surface; don't lay them on the bench and handle them with clean hands

10 Clean carefully the shafts. Lubricate lightly the O-ring and introduce the rotating part of the seal, possibly by means of a conical bush. Exert pressure only with hands; avoid using metal tools

11 Be sure the mechanical seals stand on the shaft shoulder and tighten step by step the socket head screws. We suggest you should use a thread locking adhesive in order to avoid their untightening on work

12 Assemble the stationary part of the seal on rotor case, taking care to align the slot with the retainer pin, already arranged on seat bottom

13 Clean carefully the seal slide surfaces and assemble the rotor case delicately in order not to damage the seals and be sure it is well set on plugs. Clamp the back nuts

14 Assemble the rotors, setting them on pitch setting, according to reference marks (1-2). Clamp the rotor nuts (see cap.1.3.6). In order to stop turning, interpose a non metal element between rotors

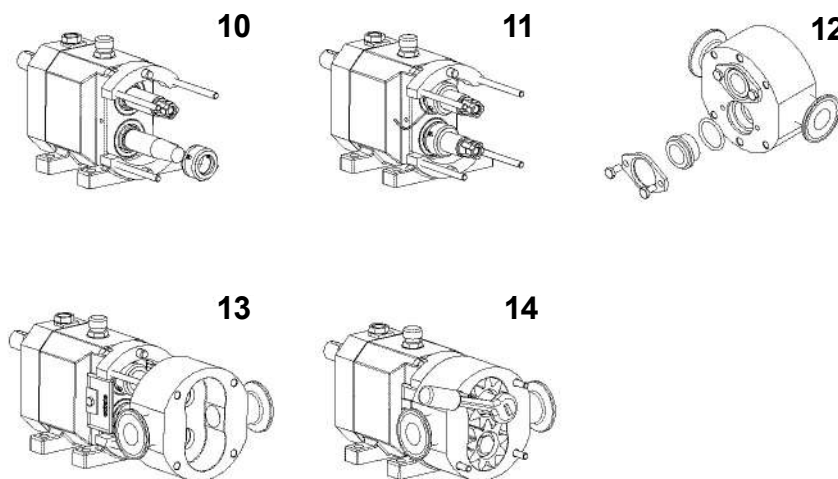

5.7.3 DISASSEMBLY OF THE BEARINGS BOX

15 After disassembling the rotor case, drain the oil and the remove drive key on shaft

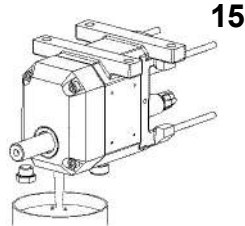

16 Remove the gear cover and make a reference mark on gears in order to respect the right timing while reassembling

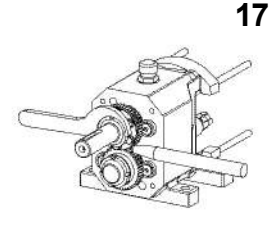
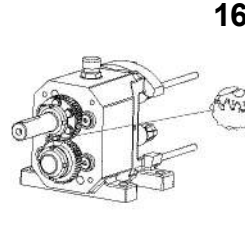

17 Disconnect the retainer keys on lock washers

18 Unscrew the gear ring nut, inserting a non metal wedge between gears in order to stop turning

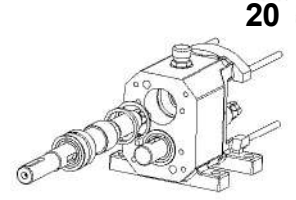
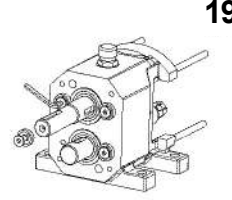
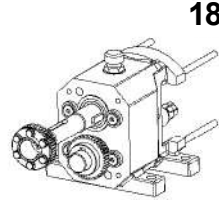

19 Disassemble the shafts, unscrewing the fl ahead screw, with the lock washer

20 Extract the shafts by the posterior side of the pump

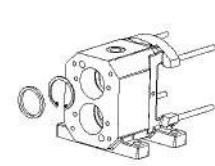
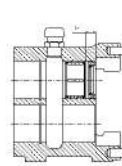
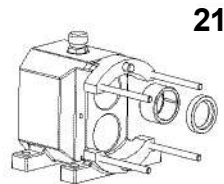

21 extract the oil retainer and the external rings of the front bearing

22 extract the spacers and the snap rings

5.7.4 Assembly of the bearing box

23 *BEARING ASSEMBLING PHASE*

Prepare the shafts and the bearings, checking they are without dents and burrs

23+24

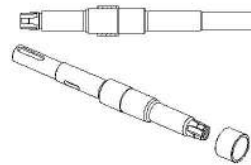

24 Drive the inner ring on the driving shaft. Repeat the operation on the driven shaft

25

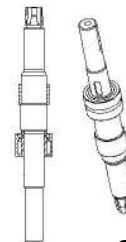

25 Assemble the rear bearing on the driving shaft and then on the driven one

26

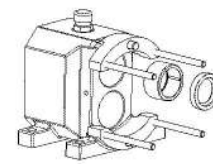

26 Drive the external bearing rings on the gear box, observing the depth on the figure (10 mm)

27

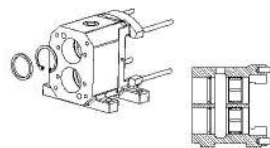

27 Insert the snap rings and the spacers for the axial setting

28

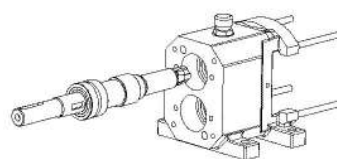

28 Assemble the shafts by the rear side of the pump, respecting the timing previously marked while reassembling, with the numbers marked "1" and "2" turned towards the high

29

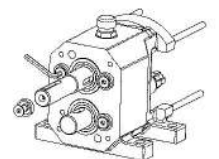

29 Fixed the rear bearings with the washers and the flathead screws

30

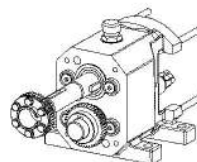

30 The gear couple is composed by a fixed gear and an adjustable one. Assemble the fixed gear, then the adjustable one with untightened screws, taking care to a first approximate rotor timing

31

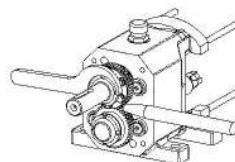

31 Tighten the retainer ring nuts with the corresponding safety washers and set rightly the suited retainer key. In order to avoid turning during operation insert a wedge in soft material among the gear teeth

32

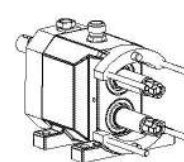

32 Assemble the rotor case and rotors as previously described and check the "Clearances" (see par.1.3.4).

If rotor clearances are not included in tolerances as prescribed in chap. 1, disassemble rotors, the rotor case and adjust the spacer according to the requested dimension

33

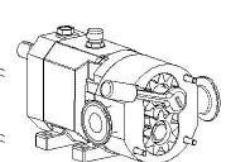

33 Being the wedge inserted among the gears tighten the rotor nuts, taking care of the driving torque (see par.1.3.6)

34 Time perfectly the rotors and tighten the screws of the adjustable gear gradually, checking the rotor timing

35 Tighten completely the adjustable gear screws taking care of the driving torque (see par.1.3.6)

N.B. IN CASE OF RE-TIMING IT'S NECESSARY TO REPLACE THE PLANE WASHERS, CAVED BY PREVIOUS CLAMPING

36 Assemble the gear cover, taking care to set the O-ring gasket and insert the key on the shaft. Put into bearing housing the oil quantity as per chap.1.3.12

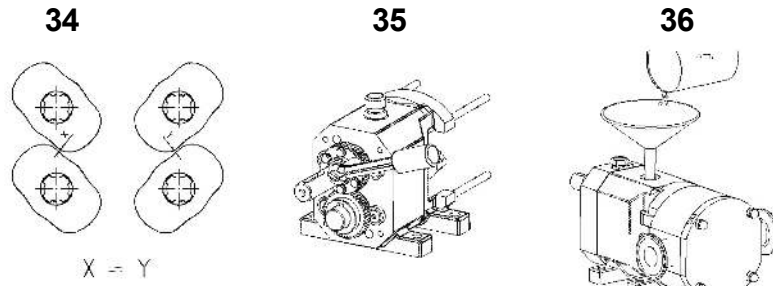

5.7.5 Disassembly of the lip seals



ATTENTION

IT IS RACCOMMENDED TO SUBSTITUTE LIP SEALS, IN CASE OF WEAR, TO BADLY AVOID SPILLAGES OF PRODUCT FROM THE PUMPING CASE AND THE MALFUNCTION OF THE PUMP
PERFORM FIRSTS OPERATIONS **1,2,3,4,5** AS IN THE PAR. 5.8.1, THEN OPERATE AS FOLLOW

6 IN BOTH CASES OPERATE AS FOLLOWS:
extract the stationary parts of the seals from rotorcase, after disassembling the retainers rings

7 after untightening the security dowels, extract the rotating part of the seal from the shaft

6 Lip seal type
HN ELRING

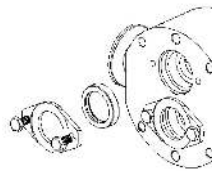

6 Lip seal type
S1 Sintek H-TPU

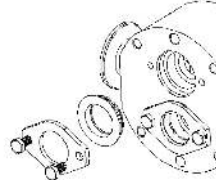

7

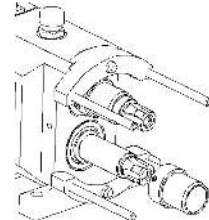

5.7.6 Lip seals assembling

8 Put the O-Ring into the rotating part of the seal and screw the security dowels

9 Lubricate the shafts before inserting the rotating part of the seals, taking care not to damage O-Ring.

Be sure the rotating part is on the shoulder of the shafts and tighten the security dowels.

It is recommended using a threads-locking glue to avoid unscrewing during the rotational motion

10 with lip seal type **HN ELRING**: Assemble the stationary part (l'anello HN Elring) on the pumping case, then assemble the retainer ring with its hexagonal-head screws

11 Clean carefully the seal slide surfaces and assemble the rotor case delicately, in order not to damage the seal and be sure it is well set on plugs.
Clamp the front nuts

12 Assemble the rotors, setting them on pitch setting, according to reference marks (1-2). Clamp the rotor nuts (see chap. 4.5). In order to stop turning, interpose a non metal element between rotors



ATTENZIONE

TAKE CARE OF THE RIGHT POSITIONING OF THE RETAINER RING, AS FOLLOWS

8



9

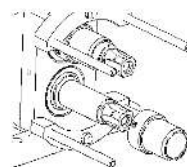

10 Lip seal type **HN ELRING**

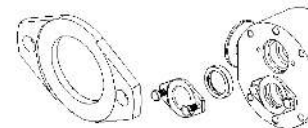

10 with lip seal type **S1 SINTEK H - TPU**:
Assemble the stationary part (SINTEK H - TPU RING) on the pumping case, then assemble the retainer ring with its hexagonal-head screws

10 Lip seal type **S1 Sintek H-TPU**

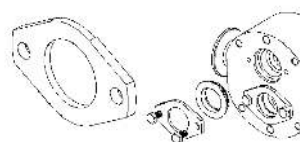

11

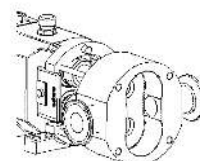

12

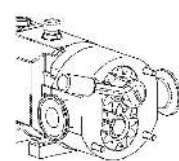

5.8 Disassembly and assembly operations of size B1/B2/B3/B4/B470/B490 PUMP

This section lists the disassembly / assembly operations of the B1/B2/B3/B4/B470/B490 size lobe pump.

B105 - B110 - B115 Section

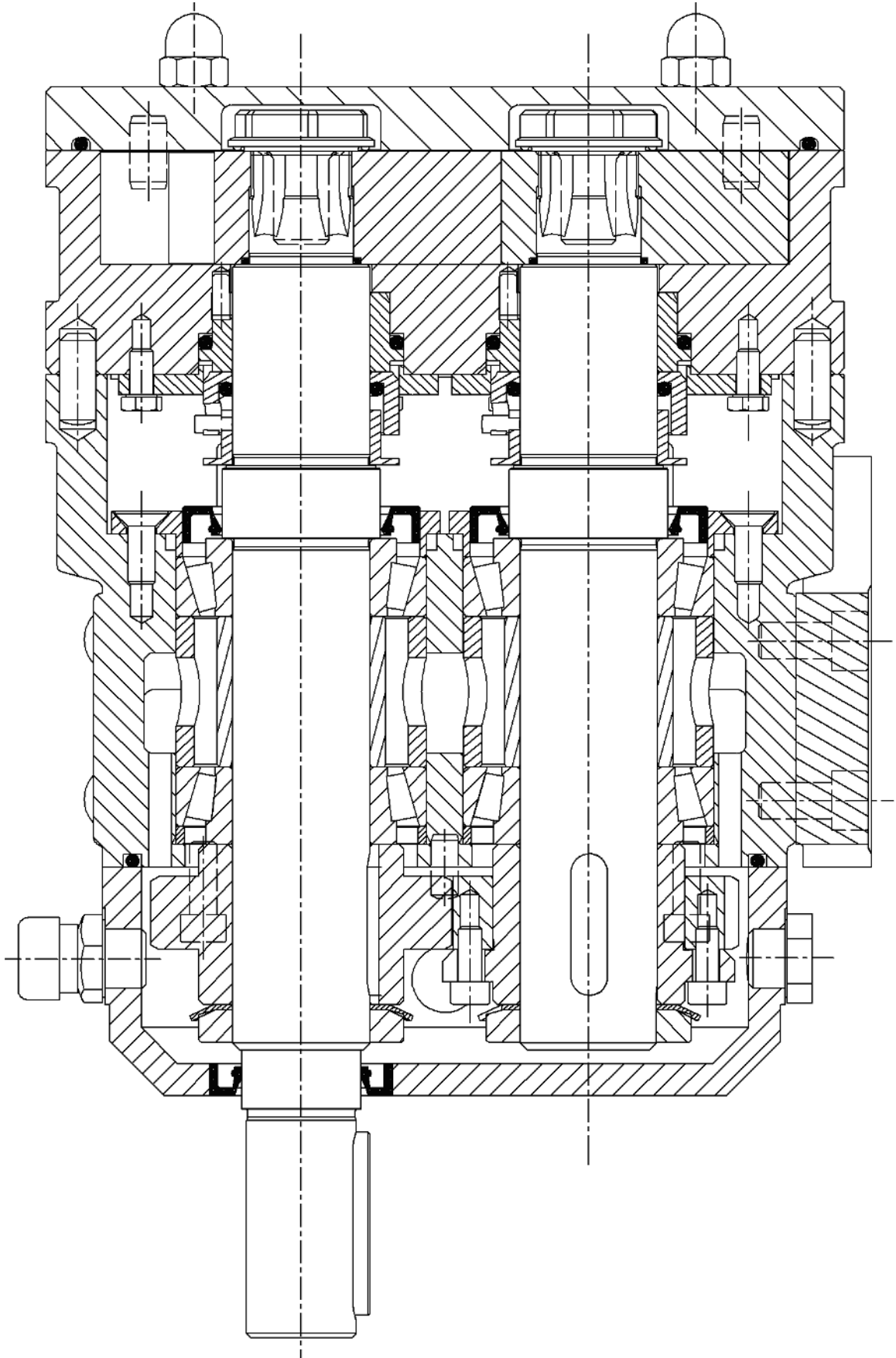

Sezione B2/B3/B4/B470/B490

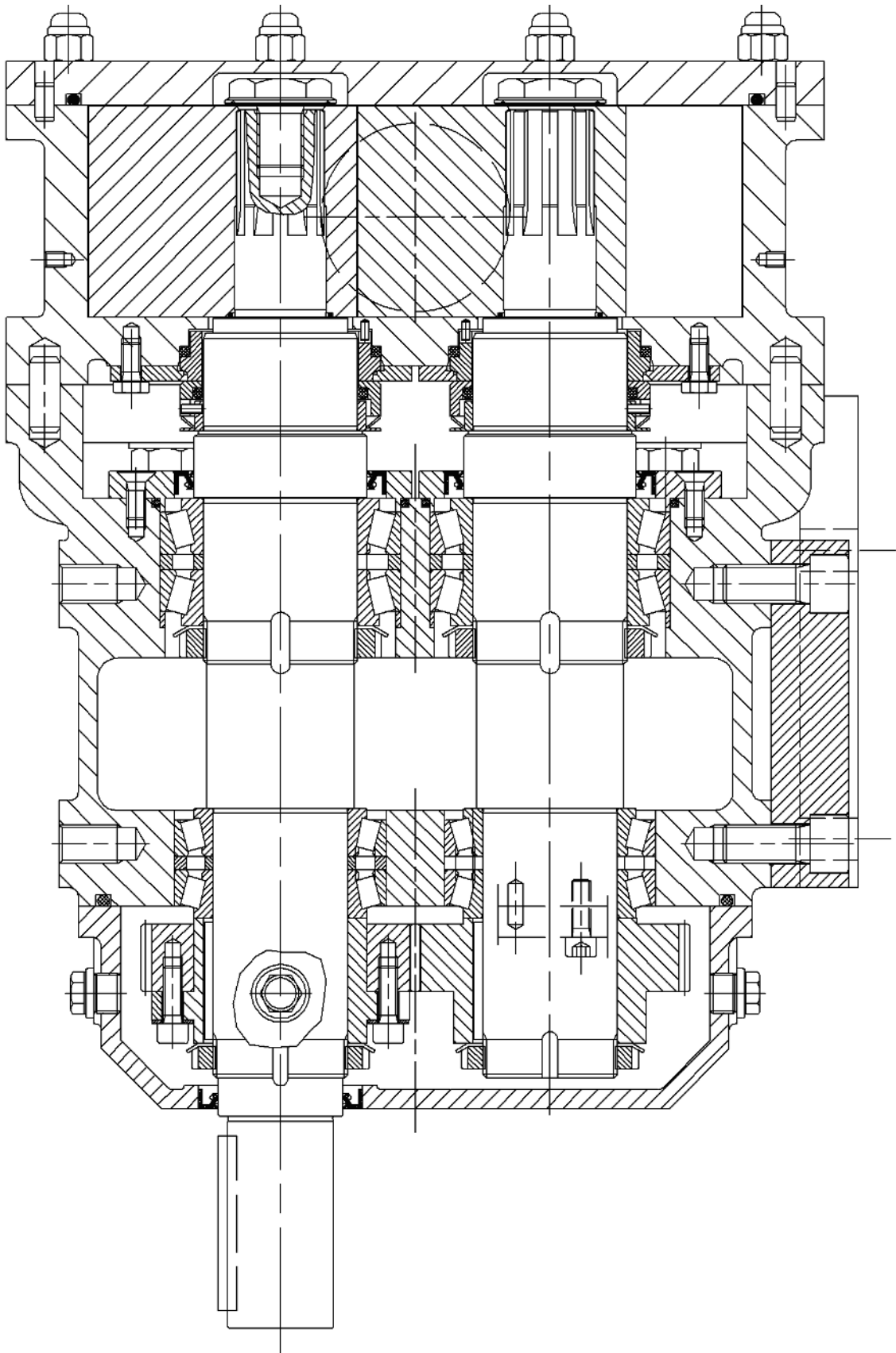

5.8.1 Disassembly of the pumping body

- 1** Remove the front nuts and exert leverage in the provided slots on cover
- 2** Unscrew anticlockwise the rotor nuts, interposing a non metal element between the rotors, making them stop rolling
- 3** Take care of the reference marked on rotors and shafts (1-2) so that you will set them rightly while reassembling
- 4** Extract the rotors, taking care you don't damage them by means of metal tools
- 5** Unscrew the back nuts and extract the rotor case
- 6** Extract the stationary part of the mechanical seal from rotor case
- 7** Untighten the socket head screws on mechanical seal
- 8** Extract the rotating part of the mechanical seal from the shaft

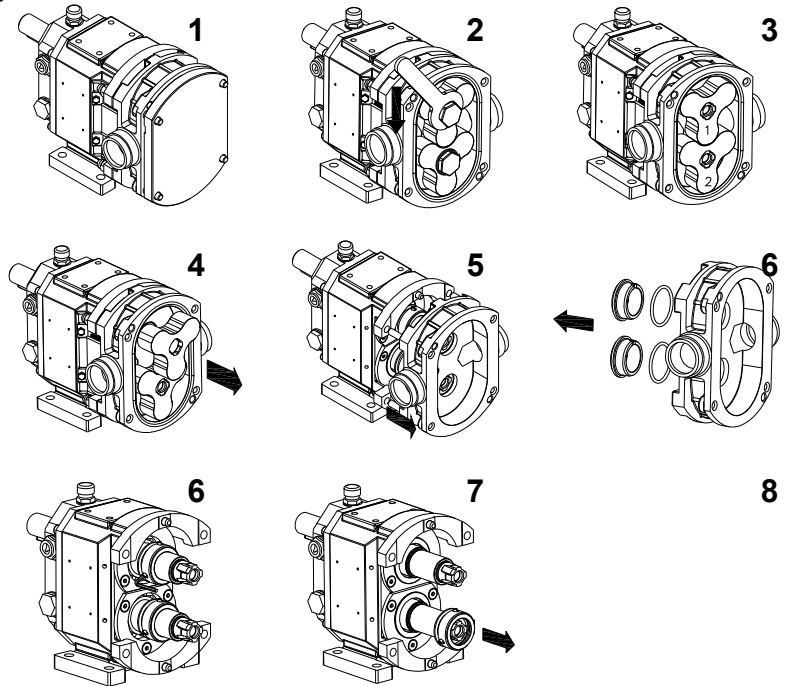

5.8.2 Assembly of the pumping body



ATTENTION

9 During the following operations, take care you don't damage the lapped seal surface; don't lay them on the bench and handle them with clean hands

- 10** Clean carefully the shafts. Lubricate lightly the O-ring and introduce the rotating part of the seal, possibly by means of a conical bush. Exert pressure only with hands; avoid using metal tools
- 11** Be sure the mechanical seals stand on the shaft shoulder and tighten step by step the socket head screws. We suggest you should use a thread locking adhesive in order to avoid their untightening on work
- 12** Assemble the stationary part of the seal on rotor case, taking care to align the slot with the retainer pin, already arranged on seat bottom

13 Clean carefully the seal slide surfaces and assemble the rotor case delicately in order not to damage the seals and be sure it is well set on plugs. Clamp the back nuts

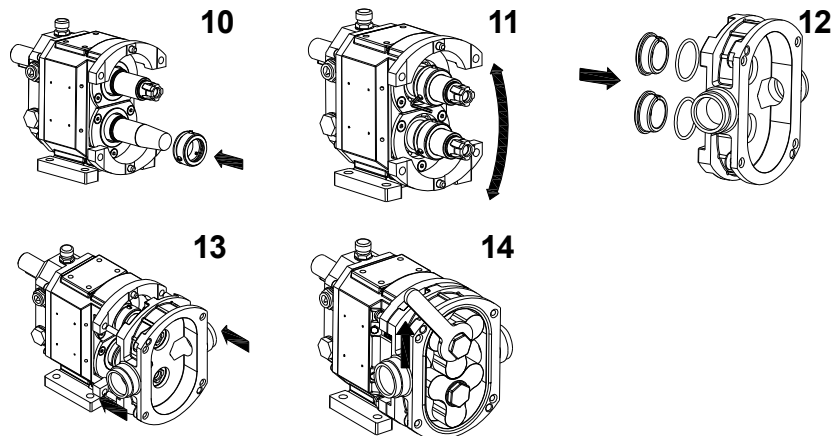

14 Assemble the rotors, setting them on pitch setting, according to reference marks (1-2). Clamp the rotor nuts (see cap.4.5). In order to stop turning, interpose a non metal element between rotors

5.8.3 Disassembly of the bearings box

15 After disassembling the rotor case, drain the oil and the remove drive key on shaft

16 Remove the gear cover and make a reference mark on gears in order to respect the right timing while reassembling

17 Disconnect the retainer keys on lock washers

18 Unscrew the gear ring nut, inserting a non metal wedge between gears in order to stop turning

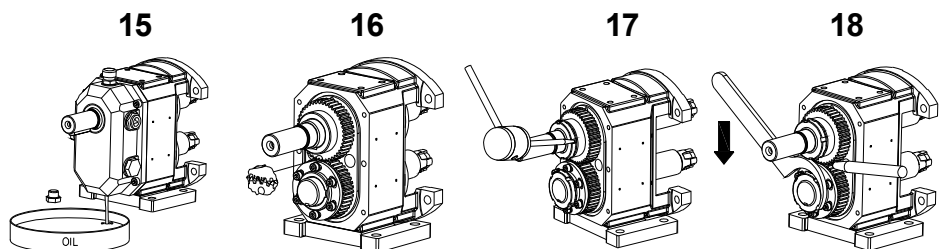

19 Extract the gears, exerting leverage between the bearing housing and the gears side, without damaging the toothing outline

20 On assembling and disassembling we suggest you should replace the gears with a spacer in order not to break down the pre-assembled bearing

21 Remove the bearing retainers

22 Extract the shafts by means of a non metal hammer

23 Mark the spacers for the axial shaft adjustment, then replace them rightly while re-assembling

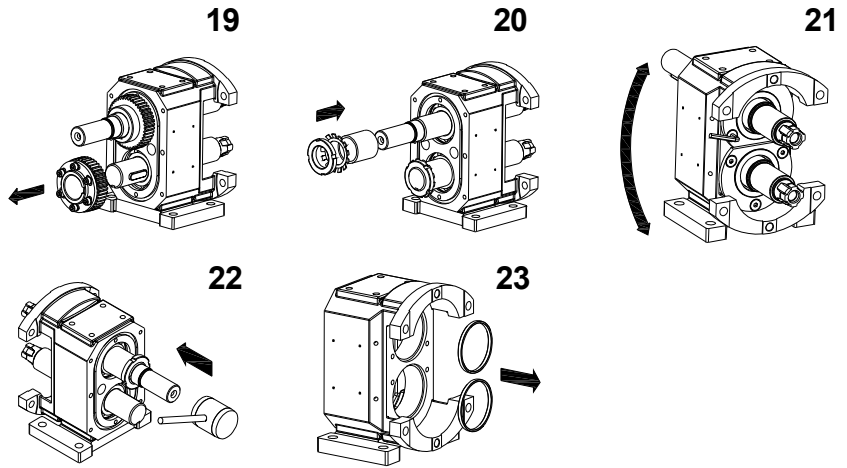

5.8.4 Assembly of the bearings box

24 *FRONT BEARING ASSEMBLING PHASE1*

If you replace bearings with others that are not supplied by OMAC, you must mark, with the electric pen, the internal ring of a bearing with the # symbol. Check with depth micrometer gauge the dimension "x" according to the table, take it without the inner spacer and the inner ring with roller set on the opposite side of #

25 PHASE 2

USE GLOVES. Heat the inner ring # up to ca 150° C and assemble it on the shaft. Wait for the temperature to drop to room temperature. Value of the measurement "X" (+/- 0.02)

26 PHASE 3

Assemble the bearing. Insert the inner spacer the first time just lapped with lapping machine. Consider the axial clearance between the rollers and carry out another lapping until you obtain a preloading on the bearings of about 0,05 mm. The best assembling is obtained when the bearings, tightened with the ring nut, roll freely and the outer spacer is slightly blocked but moves exerting a radial pressure with fingers. For tightening torques see chap. 1

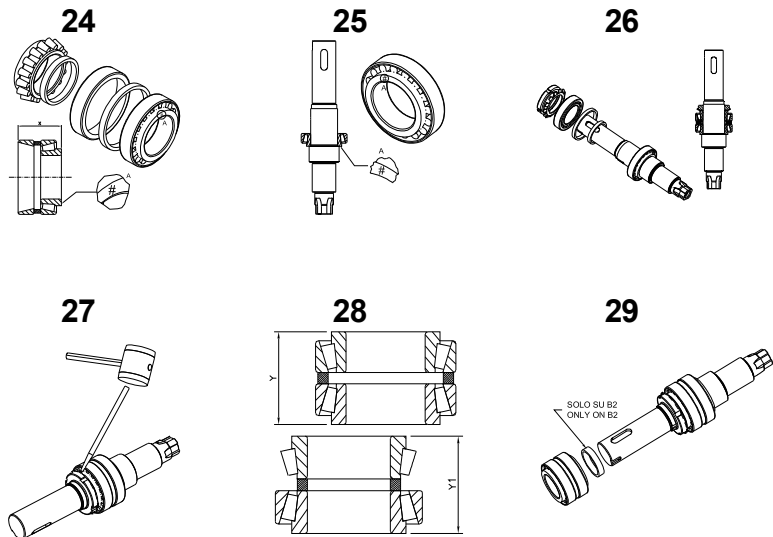

27 Assemble the pre-assembled front bearing, tighten firmly the ring nut and set the retainer key in the ring nut slot

IMPORTANT: Put all keys of the safety washer up to the ring nut in order to let the spacer pass for the axial adjustment

28 REAR BEARING ASSEMBLING PHASE1

Measurement of the "Y" dimension without the inner spacer

29 ATTENTION Bearing spacer (pos. n°10 fi g.12.2) has to be placed only on B2 size.

30 PHASE 2

Measurement of the "Y1" dimension without the outer spacer, without an outer ring and with the inner spacer, which must be inserted the first time just lapped, then the second time with the correct measure in such a way that: $Y1 = Y - \begin{matrix} -0.05 \\ -0.10 \end{matrix}$

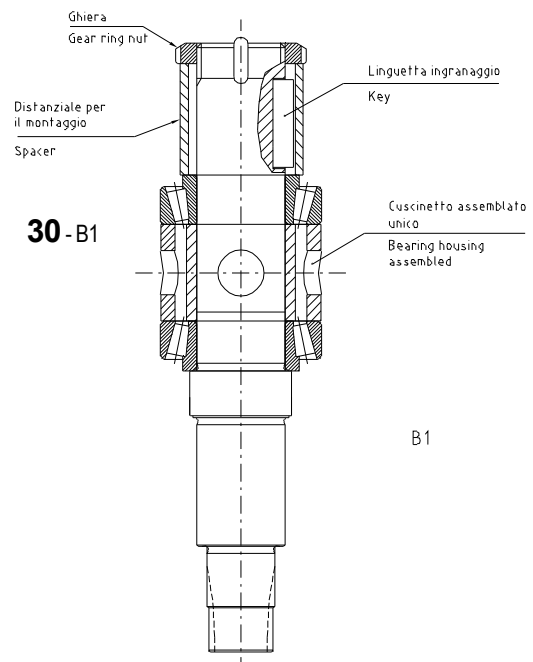

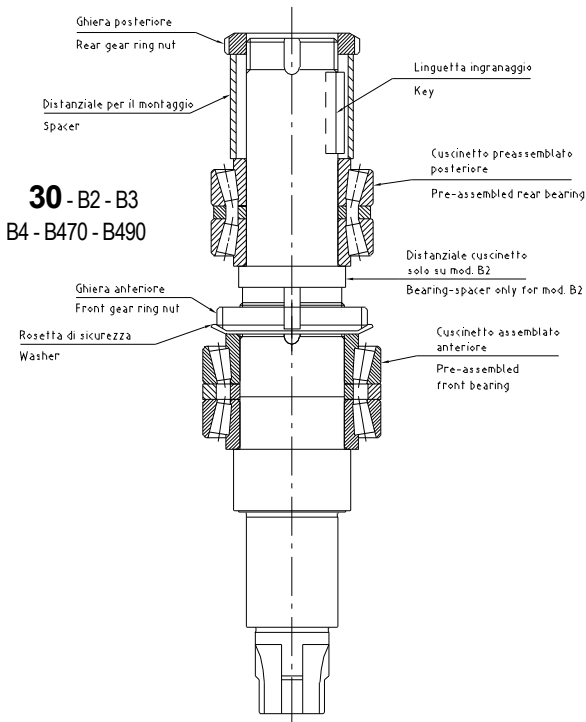

31 Assemble the pre-assembled rear bearing, tighten the ring nut inserting a spacer suitable for replacing the gear, in order to keep assembled the bearing during the assembling operations

32 Set the spacers for axial shaft adjustment and assemble the shafts with the already fixed bearings

33 Set the O-ring gasket in its seat and assemble the bearing retainers with oil lip seal already fixed. Assemble the rotor case and rotors as previously described and check the "Clearances" (see chap.1)

34 If rotor clearances are not included in tolerances as per chap. 1, disassemble rotors, the rotor case and adjust the spacer according to the requested dimension. N.B. A spacer set can be requested to the manufacturer company

35 Remove the spacers used for the assembly and insert the keys for gear drive in their seats with a lightly forced connection

36 The gear couple is composed by a fixed gear and an adjustable one. Assemble the fixed gear, then the adjustable one with untightened screws, taking care to a first approximate rotor timing

37 Tighten the retainer ring nuts with the corresponding safety washers and set rightly the suited retainer key. In order to avoid turning during operation insert a wedge in soft material among the gear teeth

38 Being the wedge inserted among the gears tighten the rotor nuts, taking care of the driving torque (see chap.1)

39 Time perfectly the rotors and tighten the screws of the adjustable gear gradually, checking the rotor timing
N.B. IN CASE OF RE-TIMING IT'S NECESSARY TO REPLACE THE PLANE WASHERS, CAVED BY PREVIOUS CLAMPING
Tighten completely the adjustable gear screws taking care of the driving torque (see chap.1)

40
Assemble the gear cover, taking care to set the O-ring gasket and insert the key on the shaft.
Put into bearing housing the oil quantity as per chap.1

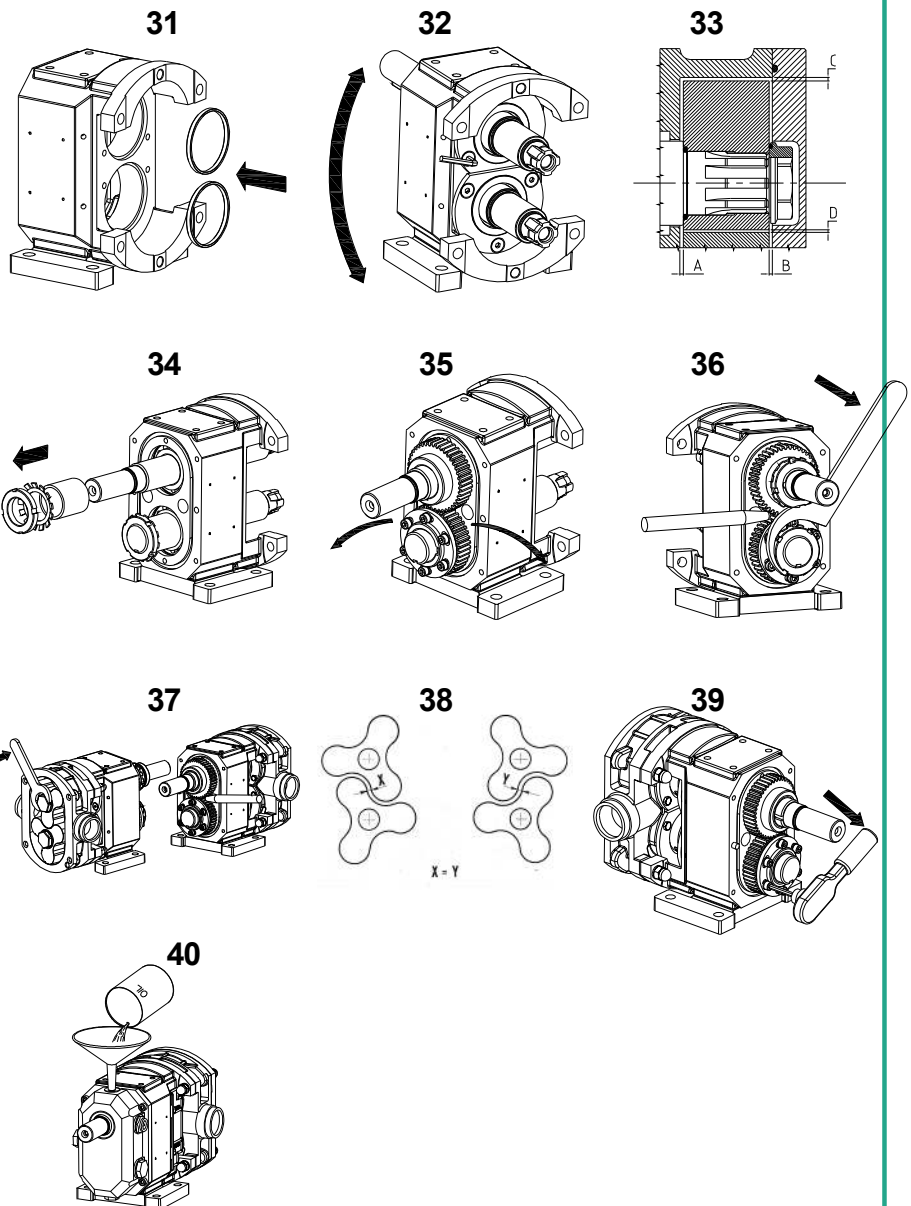

5.9 Disassembly and assembly operations of B550/B660/B680 size pump

This section lists the disassembly / assembly operations of the B550/B6 size lobe pump.

B550 Section

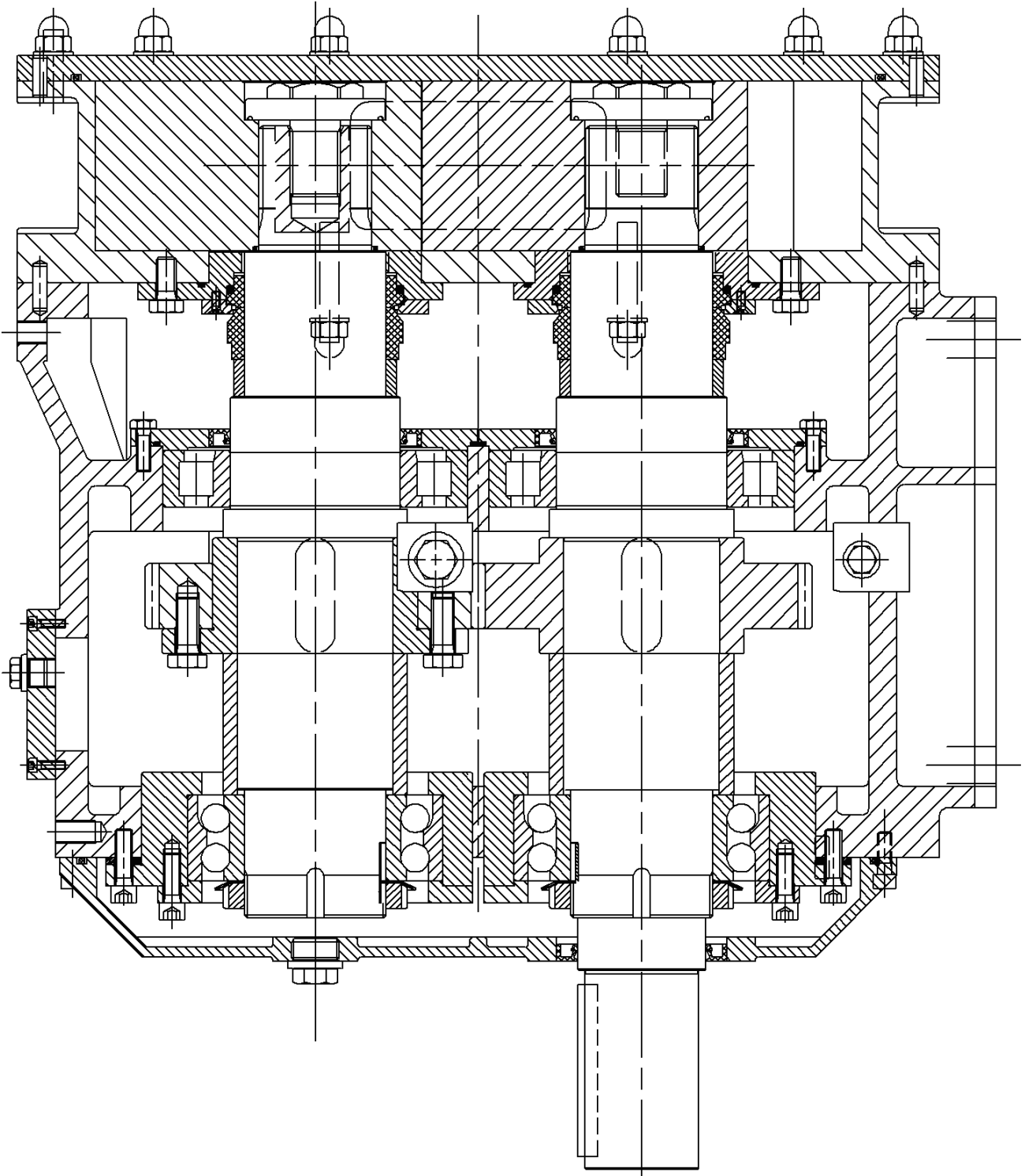

B660 B680 Section

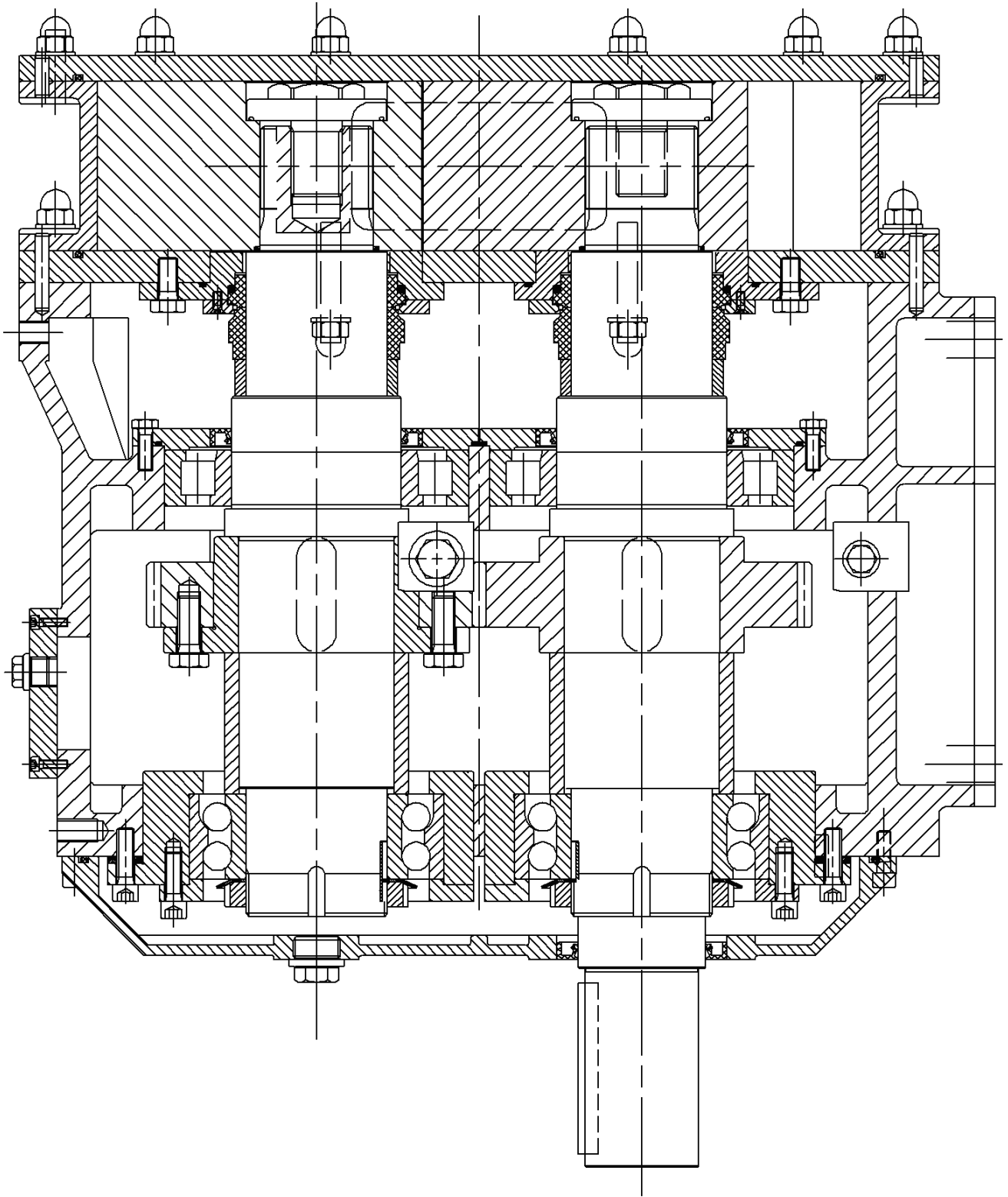

5.9.1 Disassembly of the B660/B680 pumping body

1 Remove the end cover and untighten the two locking nuts of the rotors

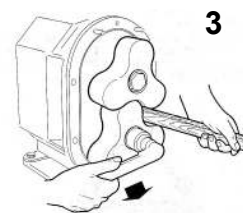
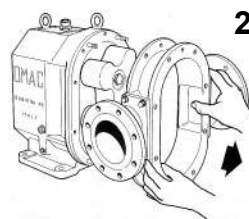
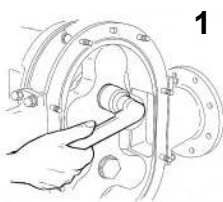

2 Untighten the back nuts and remove the rotor case

3 Unscrew anticlockwise the rotor nuts, interposing a non metal element between the rotors, making them stop rolling

4 Take care of the reference marked on rotors and shafts (1-2) so that you will set them rightly while re-assembling

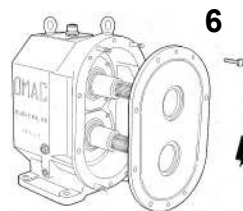
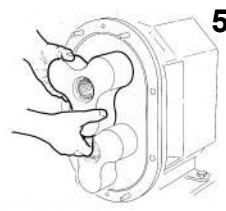
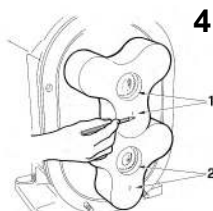

5 Extract the rotors, taking care you don't damage by means of metal tools

6 Untighten the two security screws and remove the seal flange

7 Extract the stationary part of the seal from the support fixed on seal flange

8 Untighten the socket head screws on mechanical seal

9 Extract the rotating part of the seal from the shaft

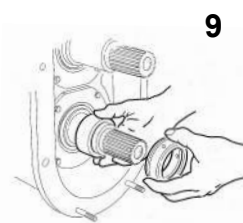
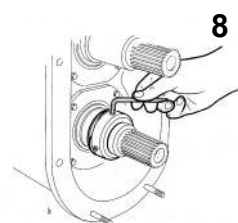
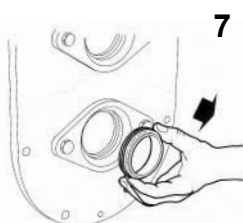

5.9.2 Assembly of the B660/B680 pumping body



DANGER

10 During the following operations, take care you don't damage the lapped seal surfaces; don't lay them on the bench and handle them with clean hands

11 Clean carefully the shafts. Be sure the spacers for the seals are set (295). Lubricate lightly the O-rings and insert the rotating part of the seals on the shafts.

Exert pressure only with hands; avoid using metal tools

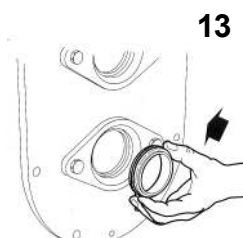
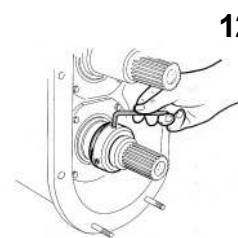
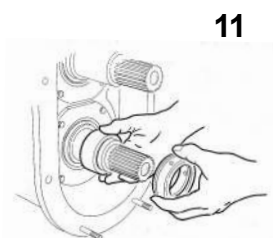

12 Be sure the mechanical seals stand on the shaft shoulder and tighten by degrees the socket head screws. We suggest you should use a thread locking adhesive in order to avoid their untightening on work

13 Assemble the stationary part of the seals on supports, taking care to align the slot with the retainer pin. Assemble these supports on seal flange, setting the O-ring

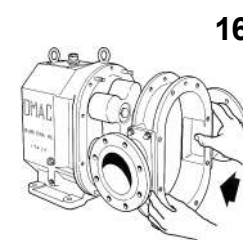
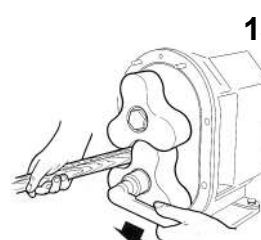
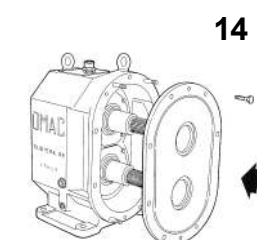

14 Clean carefully the seal slide surface and assemble the seal flange delicately in order not to damage the seals. Be sure the flange is set according to reference pins and tighten the suited screws

15 Assemble the rotors, setting them on pitch according to the reference marks (1-2). Clamp the rotor nuts (see tab. 14). In order to stop turning, interpose a non metal element between rotors. Tighten the rotor nuts (see chap.1)

16 Assemble the rotor case, setting the O-ring

5.9.3 Disassembly of the B550/B660/B680 gear box

17 After disassembling the rotor case remove the oil and the drive key on shaft

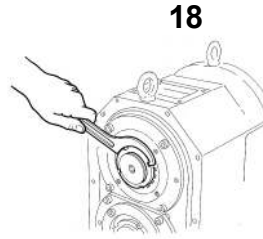

18 Remove the gear cover, disconnect the retainer keys of the lock washer and unscrew the ring nuts

19 Stand the pump upright and extract the two bearing supports, making use of the threaded holes for removal.

Doing so you will remove the spacers for axial adjustment too, which should be marked and separated for a right re-setting while assembling

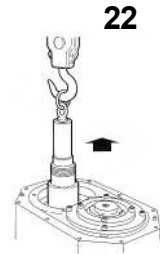
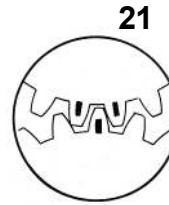
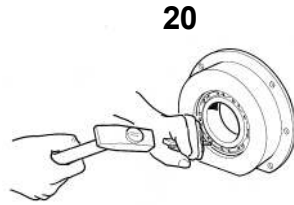

20 Remove the ball bearing from its support, taking away the bull ring

21 Mark the gears in order to set them rightly while reassembling

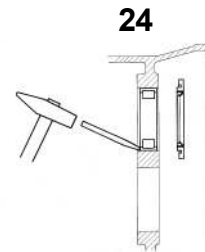
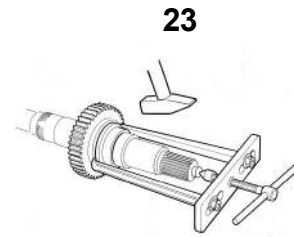

22 Withdraw the shafts, with the gears, still inserted. For this operation we suggest a mechanical lifting equipment, which can use the threaded holes arranged on shaft ends

23 Remove the inside ring of the roller bearing by means of an extractor. Remove the gear taking care not to damage the tothing outline

24 Remove the bearing retainer and extract the outer ring of the roller bearing from the bearing box

5.9.4 Assembly of the B550/B660/B680 gear box

25 Assemble the outer rings of the roller bearings on the bearing housing, using a bearing retainer to set them axially, because no counter-boring is arranged.

Assemble the bearing retainer without seal rings

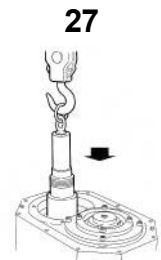
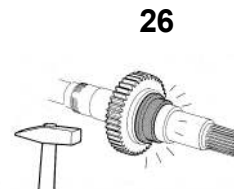
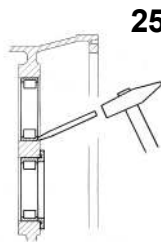

26 USE GLOVES. The inner ring of the roller bearing is assembled with a interference, therefore we suggest a shrink fitting, heating the ring in 90 °C oil bath, in order to avoid any seizure. Insert the gear keys in their seats with a lightly forced connection.

IMPORTANT: Assemble the adjustable gear on the shaft, which will be set up on the pump

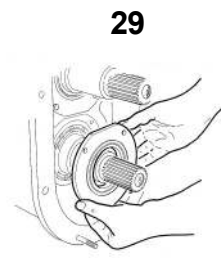
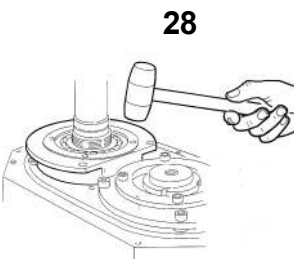

27 Assemble the shafts. If the gears haven't been removed from the shafts, respect the timing previously marked while re-assembling

28 Insert the spacers (10) on the shafts and assemble the supports (75) with the ball bearings already connected. Set the spacers for axial adjustment (11) and tighten the screws

29 Assemble the seal rings (18) on bearings retainers (9)

30 Assemble the rotor case as previously described; tighten the retainer ring nut with the corresponding lock washers and set rightly the retainer keys. In order to avoid turning during operation insert a non metal wedge between rotors

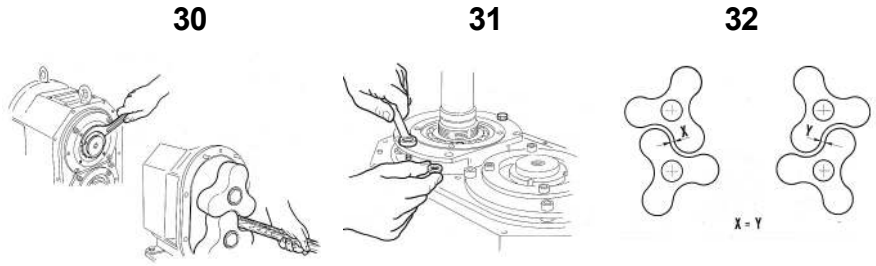

31 If clearance are not included in tolerances as per cap.4.3, untighten the screws which lock the back bearing supports, remove the spacers and adjust them according to the requested dimension.

N.B. a spacer set can be requested to the manufacturer company

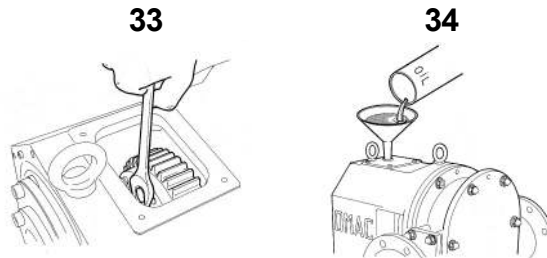

32 Time perfectly the rotors and tighten the screws of the adjustable gear gradually checking the rotor timing. You can reach the adjustable gear through a window arranged on the top of the bearing housing

33 Tighten completely the adjustable gear screws taking care of the driving torque as described in chap.4.5

N.B. IN CASE OF RE-TIMING IT'S NECESSARY TO REPLACE THE PLANE WASHERS, CAVED BY PREVIOUSLY CLAMPING

34 Assemble the gear cover, taking care to set the O-ring and insert the key on the shaft. Put into gear box the oil quantity as per chap. 1

B550-B660-B680 PUMPS DRIVE SHAFT POSITION INVERSION

1 To invert the position of the drive shaft, one must completely disassemble the shafts from the pump body, as per instructions above.

IMPORTANT!

Re operation n. 20: mark the B rotors, bearings supports (I%) and the adjustment spacers (11) to position them on the same shaft during assembly.

2 Remount the shafts in inverted positions, each with its details marked during disassembly. The gears must stay in the original position with the same tooth and opening in the previous position to keep the timing. When the assembly is complete, check that the clearances and the timing are within the tolerances under chapter 4.3. Introduce the amount of oil indicated in chapter 1.

5.10 POST MAINTENANCE CHECK

After maintenance activities, one must carry out tests to ensure the proper operation of the LDPU, before restarting the unit. To carry out these tests refer to the check-list of section 4.5.1 of this manual.

CHAPTER 6: B SERIES LDPU DECOMMISSIONING

Where provided, the contents of this chapter is specifically addressed to the internal company maintenance engineer. This person, named directly and formally by the Customer company management; has at least two years experience in this role and has the required technical abilities for operating in safety conditions and understand and interpret the technical indications contained in the above mentioned documentation properly.

During assembly and disassembly operations of the LDPU, as in occasion of its routine and extraordinary one must wear the personal protection equipment, according to the operation and risk connected to the activity performed by the appointed operator, as described in section 1.9.

6.1 Disconnection from the sources of energy



DANGER

Before disconnecting the LDPU from its energy supplies, make sure that the plant or part of it is contained in complies with the following conditions:

- absence of process fluid and eventually washing of parts in contact with process fluid;
- absence of residual pressure;
- temperature of contact surfaces not dangerous.

As already highlighted inside this use and maintenance manual, the LDPU must be disconnected from the energy sources:

- electric (motorisation);
- hydraulic (driving force, flushing and/or aseptic unit when present);
- pneumatic (driving force, pneumatic safety valve, when present).

Disconnection of the LDPU from the energy sources requires strict compliance with the indications below:

- with reference to Chapter 4, stop operation of the LDPU (of every component) and consequently stop operation of the plant;
- once operation of the LDPU has been stopped, put every main switch in the plant in position "0", so that every part of the line is insulated from the power network (electric, etc.);
- make sure that the various "presence of voltage" warning lights are switched off;
- if an aseptic system and/or flushing system are present, make sure that the auxiliary liquid supply hydraulic control unit is switched off;
- when the LDPU requires compressed air to operate (presence of pneumatic safety valve), move the compressed air supply/discharge tap lever in close/discharge position and wait for a few minutes. This way the machine is insulated from the pneumatic supply network and furthermore the residual energy present inside the pneumatic circuit is discharged;



DANGER

Before disconnecting the lobe pump from its energy supplies, make sure that the upstream energy supply has been interrupted, that the hydraulic supply has been interrupted, that the compressed air has been interrupted and there is no residual energy (i.e. for example: that the compressed air present in the pneumatic plant has been discharged). Also check that the compressed air supply tap of your plant is closed.

- in case of electric supply, making sure that you do not have any parts of your body near the damp areas, remove the plug from the electric system of the machine, from the electricity socket;
- if pneumatic supply is present, free the fixing of the pneumatic supply pipe;
- if hydraulic supply is present, free the fixing of the hydraulic supply pipe;
- pay utmost attention to possible leaks of remaining liquids. These leaks must be dried immediately in order to prevent slipping.

It is reminded that the operations needed to disconnect the LDPU from its energy supplies, for the complexity of the numerous checks / tests to be carried out, must be performed by skilled personnel only.

Please be reminded that to operate the LDPU may need electricity, hydraulics and compressed air; connections that need to be disconnected carefully, taking care to verify the absence of stored residual energy in addition to water leaks.



DANGER

if not formally authorised, do not attempt to disassemble parts of the LDPU.

O.M.A.C. S.r.l. is not liable for damages to things or persons during disassembly carried out by unauthorised personnel.

6.2 Disassembly

With reference to chapter 3, using PPE and the tools described herein, free the pump from its fixings, following the indications, in section 3.3 (installation), in reverse order



ATTENTION

- use the proper P.P.E.;
- use the adequate tools;
- follow the procedure described in section 3.3 in reverse order;
- first of all disassemble the any optional features present on the pump;
- unscrew the suction and delivery connections from the plant;
- remove the fixing screws from the base;
- extract the LDPU from its position, using hoisting equipment.



DANGER

Considering the mass of the lobe pump, the hoisting and transfer stages must only be carried out by skilled personnel and under the direct supervision of technical personnel headed by the respective manufacturers.

- using a clean cloth that does not leave any fluff, clean the external parts accurately (both externally and the easily accessible internal parts);



WARNING

For cleaning, only use a clean cloth that does not leave any fluff.

- free the LDPU from its anchoring;
- the unit is now free from its anchoring and ready to be handled, as defined in chapter 2 of this manual.

6.3 Storage after its use

After the disconnection and cleaning operations, put the LDPU in its original packaging, fixing it and trying to ensure good stability. Using appropriate hoisting means, put the packed LDPU in a dry sheltered place at room temperature.

6.4 Demolition and disposal

Following the indications of the European Community Directives in force at the time of demolition, the user must take care of the disposal of the materials that make up the machine.

It is good practice for the user, before demolishing the lobe pump, to communicate all the data carried on the nameplates and relating to the components that will be demolished to the relative manufacturers.

The LDPU is made with materials that are not subject to specific obligations for toxicity and / or harmfulness and therefore do not require particular disposal procedures, except for the oils present (with reference to section 5.6); substances that must be disposed of in compliance with the legislative obligations in force, as indicated in the relative safety sheet, with reference to sections 5.8, 5.9, 5.10.



WARNING

The LDPU presents some substances that must be disposed of in compliance with the legislative obligations in force.

DO NOT DISPOSE OF THESE MATERIALS IN THE ENVIRONMENT

In case of demolition, the user, in accordance with the local law regulations, must take special precautions regarding the disposal of significant materials from the environmental point of view, such as:

- plastic materials of pneumatic pipes (when present)
- coated electric cables (when present)
- any remaining toxic or corrosive substances
- Lubricant oil of the gear box.

CHAPTER 7: B SERIES LDPU SPARE PARTS

Throughout his life, the LDPU may require the replacement of consumed or worn parts. To simplify the recognition of its consumption elements, O.M.A.C. S.r.l. completes this manual with specifications defined for the identification of spare parts. They are mainly spare parts that, if required, must be replaced only by skilled technical personnel authorised by O.M.A.C.



WARNING

Only skilled personnel authorised by O.M.A.C. S.r.l. can carry out extraordinary maintenance replacement interventions, performing the replacement interventions of the components described below.

Do not try to replace parts without authorisation.

In case of replacing constructive mechanical parts that compose the LDPU, some of these need long manufacture time that can take a few months. It is advisable to have enough of the components described above in the amounts deemed necessary to limit machine down time.



DANGER

Only skilled personnel authorised by O.M.A.C. s.r.l. can carry out extraordinary maintenance interventions; do not try to replace parts of the machine if unauthorised. O.M.A.C. s.r.l. is not liable for damages to persons, animals or things deriving from unauthorised interventions.

7.1 List of spare parts and section drawings of the lobe displacement pump

Below the LDPU will be presented in its various sizes, complete with exploded view construction drawing and bill of materials table.

For each component, the tables below indicate the position in the exploded view drawing, the description, the needed amount and, depending on the model, the item code to order as spare part.

In the "amounts" column there may be one or more values present: where there are two amounts, the value marked with the asterisk only refers to the code marked with an asterisk, present on the same line, with reference to the pump model that one possesses.



AVVERTENZA

If, to replace spare parts, one needs to remove the front cover of the pump (pos. 44), it is essential to restore the pump hygiene level before putting it back into service. It is reminded that in case the "B series lobe pump" has been configured for the treatment of alimentary products, level 1 hygiene must be ensured.

7.1.1 B100: Spare parts list

7.1.1.1 B100: Pump exploded view drawing

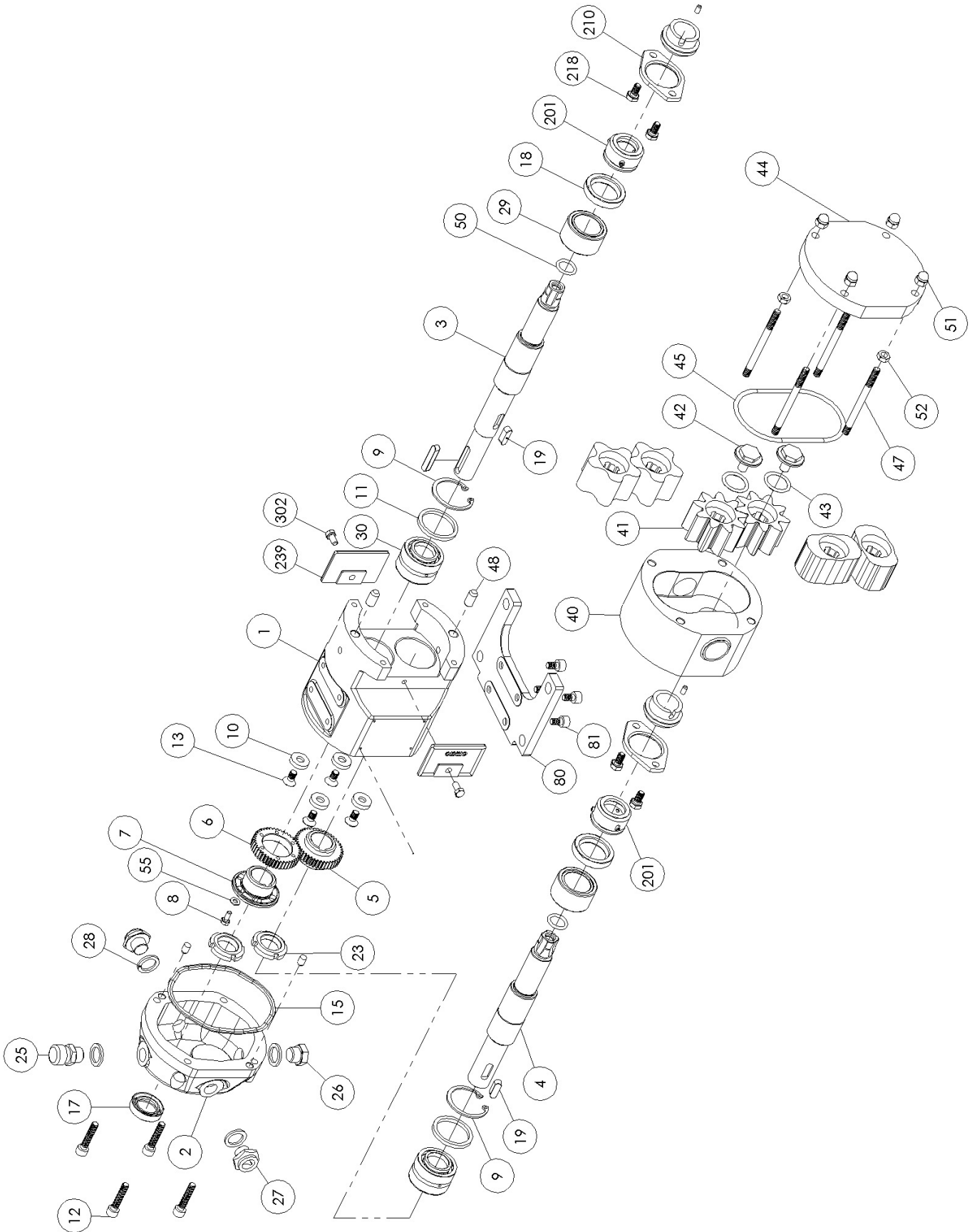

7.1.1.2 B100: Spare parts names and codes

POS.	DESCRIPTION	Q.TY	CODE	POS.	DESCRIPTION	Q.TY	CODE
1	BEARING BOX	1	2001G010	45	COVER O-RING	1	404T4337
2	GEAR COVER	1	2001L030	47	STUD	4	419A06X80
3	DRIVING SHAFT	1	2004B061	48	PIN	2	417A08X16
4	DRIVEN SHAFT	1	2004B062	50	O-RING	2	404T2050
5	FIXED GEAR	1	2008M013	51	CAP-NUT	4	414A06
6	ADJUSTABLE GEAR	1	2008M017	52	NUT	2	413A06
7	ADJUSTABLE GEAR BUSH	1	2008M038	55	PLANE WASHER	6	412F04
8	SCREW	6	410F04X10	56	BY-PASS SUPPORT	1	2013L019
9	SPLIT RING	2	421F37I	56/1	BUSH FOR SAFETY VALVE	1	2013B050
10	PLANE WASHER	4	412F06G17	57	PISTON FOR SAFETY VALVE	1	2013B057
11	AXIAL ADJUSTMENT SPACER	2	2014M030	58	COVER FOR SAFETY VALVE	1	2013L018
12	SCREW	4	411A06X30	59	ADJUSTMENT SCREW FOR SAFETY VALVE	1	2013B058
13	SCREW	4	411F06X12Z	60	THRUST WASHER	1	2013L017
15	GEAR COVER SEAL	1	404T3350	61	ADJUSTMENT RING NUT	1	2013A021
17	OIL SEAL RING	1	403Y18307D	62	BY PASS ADJUSTMENT RETAINER	1	2013L020
18	OIL SEAL RING	2	403Y25377D	63	SCREW	4	411A06X55
19	KEY	2	418F06X18	65	SCREW	2	420A05X06
20	KEY	1	418A06X30	66	SPLIT RING	1	421A025I
21	PIN	2	417A06X10	67	SPLIT RING	1	421A10E
23	GEAR RING NUT	2	415F20AUT	68	O-RING	1	404T4118
25	OIL VENT CAP	1	407L14S	69	O-RING	1	404T4150
26	OIL VENT CAP	1	407L14T	70	LOCK FOR SAFETY VALVE	1	411A05X05
27	OIL LEVEL	2	407L14L	71	SPRING	1	vedi par. 7.1.6
28	PLANE WASHER	4	407L14R	72	COVER FOR SAFETY VALVE	1	2006B025
29	FRONT BEARING	2	2019M020	80	HORIZONTAL FOOT	1	2001G100
30	REAR BEARING	2	406FNATB5904	81	SCREW FOR FOOT	4	411A06X10
40	ROTOR CASE	1	see par. 7.1.5	111	HEATED COVER	1	2006B058
41	316 S.S. GEAR ROTOR ST	2	2005B086	113	COVER JACKET	1	2006B167
41	316 S.S. 2-LOBE ST	2	2005B089	114	SCREW	4	411A06X16
41	RUBBER COATED 316 S.S. 5-LOBE	2	2005B098	115	O-RING	1	404T176
41	S.S. ANTI-SEIZURE ALLOY GEAR ROTOR	2	2005&086	239	SEAL PROTECTION	2	4034Y005
41	S.S. ANTI-SEIZURE ALLOY 2-LOBE	2	2005&089	302	SCREW	2	410A05X10
42	LOCKING NUT FOR ROTOR	2	2004B107	304	NAME PLATE	1	4034A100
43	O-RING	2	404T3075	305	RIVET	4	44301027
44	FRONT COVER	1	2006B007				

7.1.1.3 B100: Seals section drawings

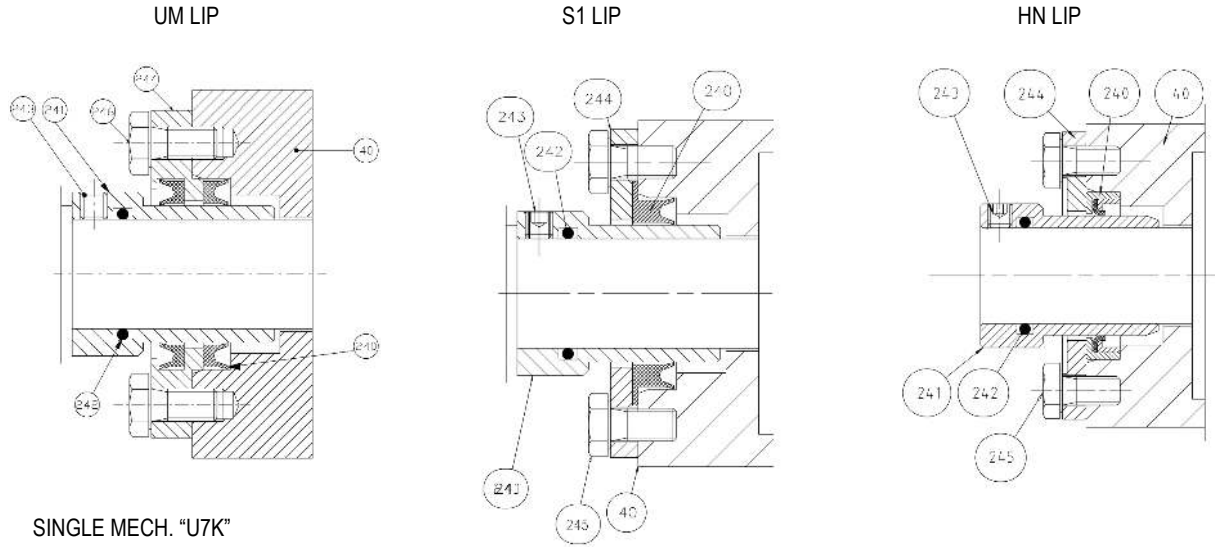

SINGLE MECH. "U7K"

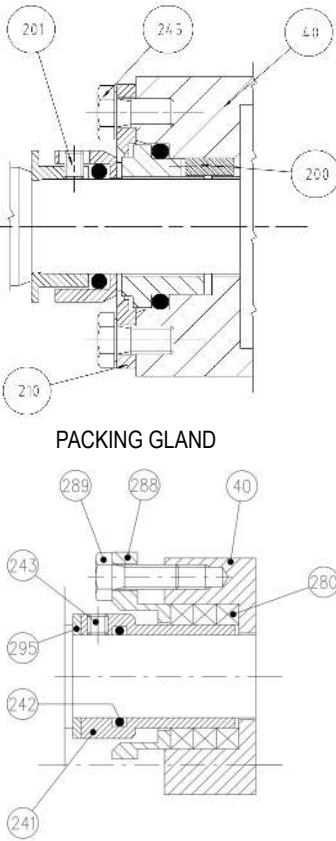

PACKING GLAND

POS.	DESCRIPTION	Q.TY	CODE	POS.	DESCRIPTION	Q.TY	CODE
200	SEAL STOP PIN	2	2014B200	240	SEAL RING UM °VITON(F.K.M.)	2	402V35255
201	MECHANICAL SEAL AISI 316 L/CARBON/EPDM	2	4U020U7KXZ7	240	SEAL RING HN ELRING	2	402HN25357
201	MECH. SEAL AISI 316 L /CARBON/F.K.M.	2	4U020U7KXZY	240	SEAL RING HN ELRING HEAT-SEALED	2	402HN25357SPE
201	MECH. SEAL 7K-XFXZ5-HX	2	4U020U7KXZ5	241	SEAL RING BUSH	2	2004B170
201	MECH. SEAL 7K-X73Z7-HX	2	4U020U7K3Z7	242	BUSH O-RING	2	404T3081
201	MECH. SEAL 7K-XY3ZY-HX	2	4U020U7K3ZY	243	SECURITY DOWEL	6	420A05X05
201	MECH. SEAL 7K-XF3Z5-HX	2	4U020U7K3Z5	244	S1 SEAL RING SUPPORT	2	2014B058
201	MECH. SEAL 7K-X7337-HX	2	4U020U7K337	245	SCREW	4	410A06X12
201	MECH. SEAL 7K-XY33Y-HX	2	4U020U7K33Y	246	SCREW	4	410A06X14
201	MECH. SEAL 7K-XF335-HX	2	4U020U7K335	280	PTFE PACKING GLAND RING KIT	1	205P25355
201	MECH. SEAL 7K-XYDKKY-HX	2	4U020U7KKKY	288	PACKING GLAND	2	2014B108
210	BALANCING RING	2	2014B015	289	SCREW	4	410A06X16
218	BALANCING RING SCREW	4	410A06X12	295	SPACER	2	2014B045

7.1.1.4 B100: Gasket or ring codes for mechanical seals

MECHANICAL SEAL MATERIALS B100 DIAMETER 20	AISI 316 L CARBON	TUNGSTEN CARBIDE CARBON	TUNGSTEN CARBIDE TUNGSTEN CARBIDE	CERAMIC CARBON	SILICON CARBIDE CARBON	CERAMIC RULON	SILICON CARBIDE SILICON CARBIDE	SILICON CARBIDE TUNGSTEN CARBIDE
U7K ROTATING RING O-RING	404U4081							
U7K STATIONARY RING O-RING	404U4112							

7.1.2 B105 B110 B115: Spare parts list

7.1.2.1 B105 B110 B115: Pump exploded view drawing

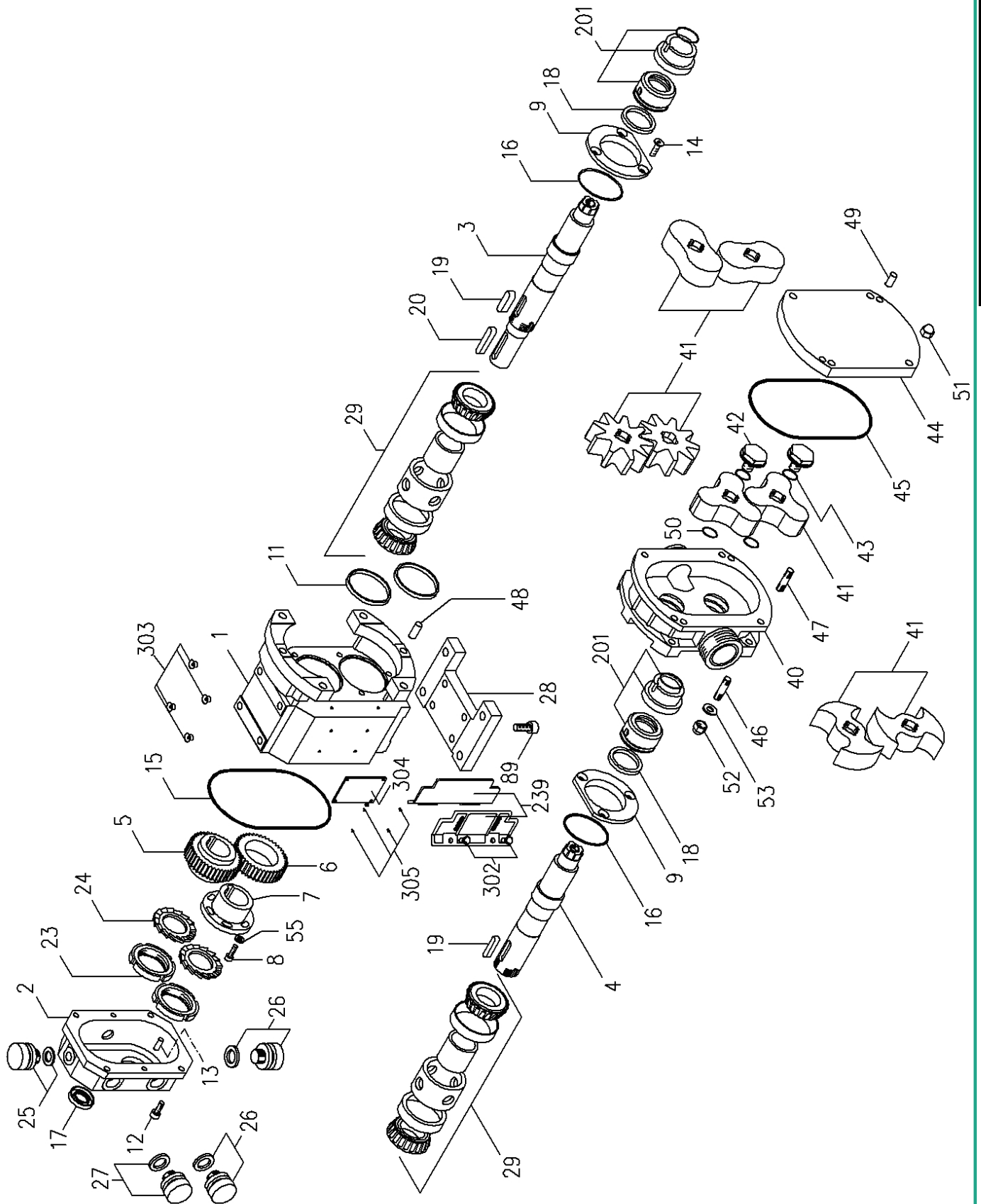

B105 B110 B115

7.1.2.2 B105 B110 B115: Spare parts names and codes

POS.	DESCRIPTION	Q.TY	B105	B110	B115
1	BEARING BOX	1		2001G001	
2	GEAR COVER	1		2001L031	
3	AISI 316 L DRIVING SHAFT	1	2004B001		2004B002
3	DUPLEX DRIVING SHAFT	1	2004D001		2004D002
3	AISI 316 L DOUBLE MECH. SEAL DRIVING SHAFT	1	2004D015		2004D016
4	AISI 316 L DRIVEN SHAFT	1	2004B029		2004B030
4	DUPLEX DRIVEN SHAFT	1	2004D029		2004D030
4	AISI 316 L DOUBLE MECH. SEAL DRIVING SHAFT	1	2004D045		2004D046
5	FIXED GEAR	1		2008M001	
6	ADJUSTABLE GEAR	1		2008M007	
7	ADJUSTABLE GEAR BUSH	1		2008M031	
8	SCREW	6		411F05X14	
9	SPLIT RING	2		2001C051	
11	AXIAL ADJUSTMENT SPACER	2		2014M024	
12	SCREW	4		411A06X16	
13	PIN	2		417A06X15	
14	SCREW	6		411A06X16S	
15	GEAR COVER O-RING	1		404T4437	
16	BEARING RETAINER O-RING	2		404T3218	
17	OIL SEAL RING	1		403Y26377D	
18	OIL SEAL RING	2		403Y35527D	
19	KEY	2		418F08X30M	
20	KEY	1		418F08X40	
23	GEAR RING NUT	2		415F30	
24	WASHER	2		416F30	
25	OIL VENT CAP	1		407L14S+407L14R	
26	OIL CAP	1		407L14T+407L14R	
26/1	OIL CAP	1		407L38T+407L38R	
27	OIL LEVEL	1		407L38L	
28	HORIZONTAL FOOT	1		2001G101	
29	FRONT BEARING (ASSEMBLED)	2		2019M001	
31	VERTICAL FOOT	2		2001A301	
32	SCREW FOR VERTICAL FOOT	8		411A08X20	
33	COUNTERFLANGE FOR ENLARGED INLET PORT	1	-	-	2006B045
34	O-RING	1	-	-	404T3281
40	PUMPING CASE	1		see par. 7.1.5	
41	3-LOBE ROTOR S.S.AISI 316 L VERSION ST	1	-	2005B002	2005B003
41	2-LOBE ROTOR S.S.AISI 316 L VERSION ST	2	-	2005B026	2005B027
41	3-LOBE ROTOR S.S.AISI 316 L VERSION SM	2	-	2005B014	2005B015
41	2-LOBE ROTOR S.S. AISI 316 L VERSION SM	2	-	2005B038	2005B039
41	RUBBER COATED 3-LOBE (5-LOBE FOR B105) BUNA-N.B.R.	2	2005B099	-	-
41	RUBBER COATED 3-LOBE (5-LOBE FOR B105) E.P.D.M.	2	-	2005B050	2005B051
41	RUBBER COATED 2-LOBE ROTOR BUNA-N.B.R.	2	-	-	-
41	RUBBER COATED 2-LOBE E.P.D.M.	2	-	-	-
41	3-LOBE ROTOR CY5SnBIM (ANTISEIZURE) VERSION ST	2	-	2005&002	2005&003
41	DUAL WING CY5SnBIM (ANTISEIZURE) VERSION ST	2	2005&087	2005&074	2005&075
41	GEAR ROTOR S.S.AISI 316 L VERSION ST	2	2005B001	-	-
41	GEAR ROTOR CY5SnBIM (ANTISEIZURE) VERSION ST	2	2005&001	-	-
42	LOCKING NUT FOR STANDARD ROTOR	2		2004B101	
43	LOCKING NUT O-RING	2		404T3100	
44	FRONT COVER	2	2006B009		2006B001

POS.	DESCRIPTION	Q.TY	B105	B110	B115
45	COVER O-RING	2		404T4525	
46	BACK STUD	4		419A08X33	
47	FRONT STUD	4		419A08X33	
48	BACK PIN	2		417A08X20	
49	FRONT PIN	2		417A08X16	
50	ROTOR O-RING	2		404T2087	
51	CAP NUT	4		414A08	
52	CAP NUT	4		414A08	
53	PLANE WASHER	4		412A08	
55	PLANE WASHER	1		412F05	
-	COMPLETE SAFETY VALVE	1		2013B001	
56	SAFETY VALVE SUPPORT	1		2013L021	
56/1	BUSH SAFETY VALVE SUPPORT	1		2013B040	
57	SAFETY VALVE PISTON	1		2013B025	
58	SAFETY VALVE COVER	1		2013L029	
59	SAFETY VALVE ADJUSTMENT SCREW	1		2013B031	
60	THRUST WASHER	1		2013L032	
61	ADJUSTMEN RING NUT	1		2013A034	
62	SAFETY VALVE ADJUSTMENT RETAINER	1		2013L036	
63	SAFETY VALVE SCREW	4		411A06X20	
64	SAFETY VALVE COVER SCREW	4		411A06X55	
65	SCREW	2		420A06X06	
66	SPLIT RING (SEEGER)	1		421A38I	
67	SPLIT RING (SEEGER)	1		421A16E	
68	SAFETY VALVE PISTON O-RING	1		404T4200	
69	SAFETY VALVE SUPPORT O-RING	1		404T3250	
70	SAFETY VALVE LOCK	1		411A06X10	
71	SPRING	1		see par 1.11.6	
72	END COVER FOR SAFETY VALVE	1		2006B031	
89	FOOT SCREW	4		411A08X20	
91	SAFETY VALVE SUPPORT	1		2013B039	
92	SCREW	4		411A06X35	
93	SUPPORT O-RING	1		404T3250	
94	PISTONE VALVOLA DI SICUREZZA PNEUMATICA	1		2013B029	
95	KEY	1		418A14X30	
96	SAFETY VALVE O-RING	1		404T4200	
97	ADJUSTMENT RING NUT	1		2013A034	
98	SCREW	2		420A05X06	
99	PNEUMATIC SAFETY VALVE COVER	1		2013A032	
100	PNEUMATIC SAFETY VALVE COVER BACK O-RING	1		404T4275	
101	PNEUMATIC SAFETY VALVE COVER FRONT O-RING	1		404T4312	
102	PISTON COVER O-RING	1		404T134	
103	PNEUMATIC SAFETY VALVE JACKET	1		2013A035	
104	SCREW	4		411A06X110	
105	THRUST RING	1		2013L024	
106	PISTON ROD THRUST O-RING	1		404T119	
107	THRUST JACKET O-RING	1		404T6300	
108	RING NUT	2		415F20AUT	
111	END COVER FOR HEATING VERSION	1	2006B059		2006B051
112	END COVER FOR ASEPTIC VERSION	1		2006B101	
113	END COVER FOR JACKET	1		2006B161	
114	SCREW	4	411A06X116		411A06X20

POS.	DESCRIPTION	Q.TY	B105	B110	B115
115	END COVER JACKET O-RING	1		404T4375	
116	ASEPTIC INTERNAL COVER O-RING	1		404V3500	
117	ASEPTIC EXTERNAL COVER O-RING	1		404V3550	
118	COUNTERFLANGE FOR ASEPTIC VERSION PUMPING CASE	2		2006B181	
119	INTERNAL O-RING FOR ASEPTIC VERSION	2		404V3168	
120	EXTERNAL O-RING FOR ASEPTIC VERSION	2		404V3231	
121	SCREW	8		411A06X20	
239	SEAL PROTECTION	2		4034Y001	
302	SEAL PROTECTION SCREW	4		410A05X10	
303	PLUG	4		44301020	
304	NAME PLATE	1		4034A100	
305	RIVET	4		44301027	

7.1.2.3 B105 B110 B115: Seals section drawings

UM LIP

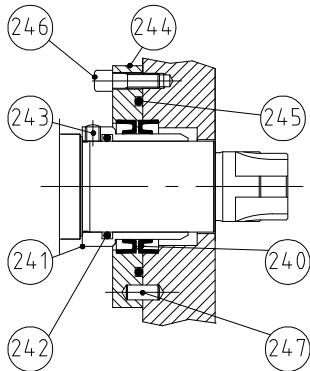

S1 LIP

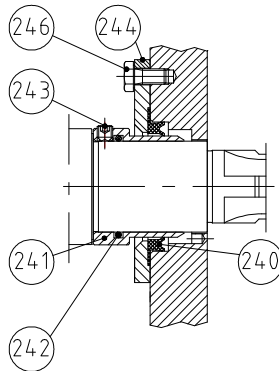

PACKING GLAND

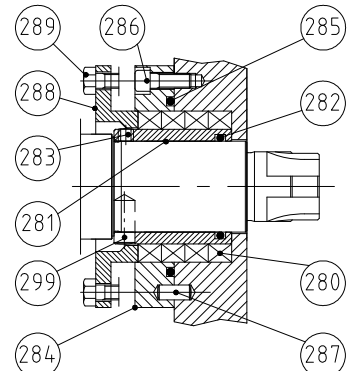

PACKING GLAND WITH LIQUID BARRIER

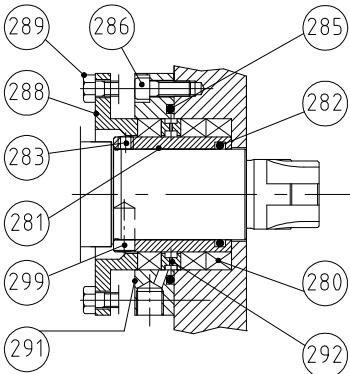

SINGLE MECHANICAL SEAL

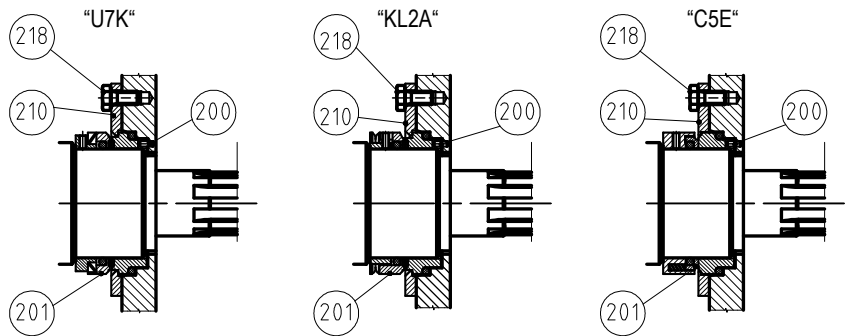

HN DOUBLE LIP

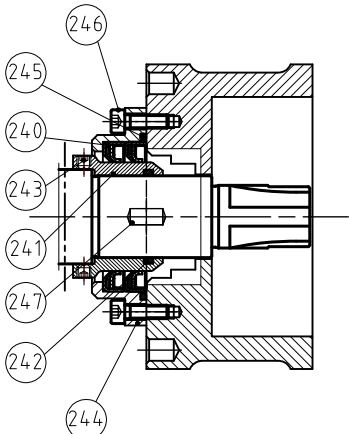

SINGLE FLUSHED MECHANICAL SEAL

"KL2A", "U7K", "C5E"

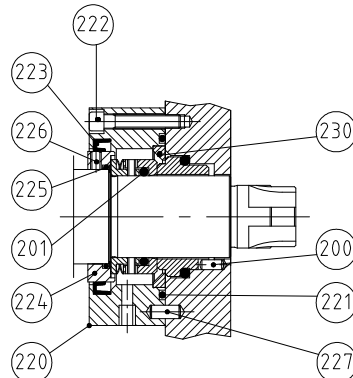

DOUBLE MECHANICAL SEAL

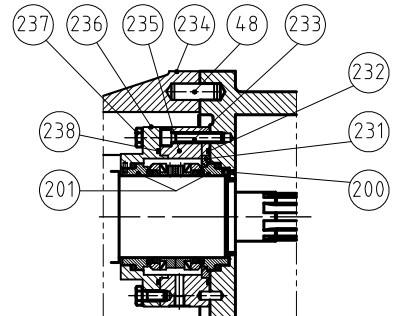

POS.	DESCRIPTION	Q.TY	B105 B110 B115	POS.	DESCRIPTION	Q.TY	B105 B110 B115
200	SEAL STOP PIN	2	2014B200	246	SCREW FOR HN LIP SEAL FLANGE	6	411A05X16
201	SINGLE MECHANICAL SEAL	2	see par. 7.1.2.6	247	PIN FOR HN LIP SEAL FLANGE	4	417A06X10
210	BALANCING RING	2	see par. 7.1.2.5	247	FOR UM LIP SEAL FLANGE	4	-
218	SCREW	6	410A05X10	280	KIT PACKING GLAND IN P.T.F.E.	1	205P38506
220	FLUSHING SEAL BOX	2	2014B141	281	STUFFING BOX SEAL SUPPORT	2	2004B161
221	O-RING	2	404T3218	282	ROTATING BUSH O-RING	2	404T3118
222	SCREW	6	411A05X30	283	SCREW	6	420A05X05
223	SEAL RING UM	2	402V57486	284	STUFFING BOX SEAL SUPPORT	2	2014B071
224	ROTATING RING	2	2004B151	285	FLANGE SUPPORT O-RING	2	404T3218
225	BUSH O-RING	6	404T2137	286	SCREW	3	411A05X14
226	GRANO DI FISSAGGIO ANELLO ROTANTE	6	420A04X05	287	PIN	4	417A06X10
227	SPINA	4	417A06X10	288	PACKING GLAND ADJUSTER	2	2014B101
230	BALANCING RING U7K (SINGLE MECH. SEAL)	2	see par. 7.1.2.5	289	SCREW	2	410A05X16
231	BALANCING RING U7K (DOUBLE MECH. SEAL)	2	see par. 7.1.2.5	290	KIT PACKING GLAND IN P.T.F.E. WITH LIQUID BARRIER	1	201P38506
232	O-RING	2	404T3218	291	FLUSHED STUFFING BOX SEAL SUPPORT	2	2014B077
233	SCREW	6	411A05X40	292	HYDRAULIC RING	2	2014B121
234	BEARING BOX FOR DOUBLE SEALS	1	2001G161	295	SPACER	2	-
235	FLUSHING BOX FOR DOUBLE SEAL	2	2014B147	296	MECHANICAL SEAL SUPPORT	2	-
236	COVER	2	2014B153	297	SUPPORT O-RING	2	-
237	SCREW	4	410A05X16	298	SCREW	4	-
238	O-RING	2	404T3218	299	PIN	2	430A05X10
239	SEAL PROTECTION	2	4034Y001	243	UM / S1 PIN	6	420A05X05
240	UM LIP SEAL IN °VITON (F.K.M.)	4	402V45356	243	HN PIN	6	420A05X05
240	UM LIP SEAL IN E.P.D.M.	4	402U45356	244	UM SUPPORT	2	2014B051
240	S1 LIP SEAL	2	402Q45357	244	S1 SUPPORT	2	2014B061
240	DOUBLE HN LIP SEAL	4	402HN40558	244	HN SUPPORT	2	2014B111
240	DOUBLE HN HEAT-SEALED	4	402HN40558SPE	245	UM O-RING SUPPORT	2	404T3218
241	ROTATING BUSH FOR UM / S1 LIP SEAL	2	2004B156	245	HN O-RING SUPPORT	2	404T3218
241	ROTATING BUSH FOR HN SEAL	2	2004B191	246	UM SUPPORTSCREW	6	411A05X14
242	BUSH O-RING FOR UM / S1 LIP SEAL	2	404T3118	246	S1 SUPPORT SCREW	6	411A05X10
242	BUSH O-RING FOR HN LIP SEAL	2	404T3118				

7.1.2.4 B105 B110 B115: Gasket or ring codes for mechanical seals

MECHANICAL SEAL MATERIALS B105 110 B115 DIAMETER 30	S.S.AISI 316 L CARBON	TUNGST. CARB. CARBON	TUNGST. CARB. TUNGST. CARB.	CERAMIC CARBON	SILICON CARB. CARBON	CERAMIC RULON	SILICON CARB. SILICON CARB.	CARB. SILICIO TUNGST. CARB.
ROTATING O-RING U7K - KL2A - C5E	404U4118	404U4118	404U4118	404U4118 (1)	-	404U4118 (2)	404U4118 (3)	404U4118 (3)
STATIONARY O-RING U7K - KL2A - C5E	404U4150	404U4150	404U4150	404U4150 (1)	-	404U4150 (2)	404U4150 (3)	404U4150 (3)

(1)ONLY KL2A, C5E (2)ONLY C5E (3)ONLY KL2A

7.1.2.5 B105 B110 B115: Balancing ring codes for single and flushed mechanical seals

MECHANICAL SEAL MATERIALS	MATERIAL CODE	STATIONARY RING	RING MODEL	B105 B110 B115	
				SINGLE SEAL	FLUSHED SEAL
S.S. AISI 316 L CARBON	3	CARBON	U7K	2014B001	2014B007
		S.S. AISI 316 L	KL2A	2014B221	2014B231
			C5E		
TUNGSTEN CARBIDE CARBON	4	CARBON	U7K	2014B001	2014B007
		TUNGSTEN CARBIDE	KL2A		
		TUNGSTEN CARBIDE	C5E	2014B215	2014B241
TUNGSTEN CARBIDE TUNGSTEN CARBIDE	5	TUNGSTEN CARBIDE	U7K	2014B001	2014B007
			KL2A		
		TUNGSTEN CARBIDE	C5E	2014B215	2014B241
CERAMIC CARBON	6	CERAMIC	KL2A	2014B221	2014B231
			C5E		
SILICON CARBIDE CARBON	A	SILICON CARBIDE	KL2A	-	-
CERAMIC RULON	7	CERAMIC	C5E	2014B221	2014B231
SILICON CARBIDE SILICON CARBIDE	8	SILICON CARBIDE	KL2A	2014B221	2014B231
SILICON CARBIDE TUNGSTEN CARBIDE	9	TUNGSTEN CARBIDE	KL2A	2014B001	2014B007

7.1.2.6 B105 B110 B115: Single and double mechanical seals codes

COD.	SEAL MATERIAL	SEAL MODEL	B105 B110 B115	COD.	SEAL MATERIAL	SEAL MODEL	B105 B110 B115	
3 Q3	S.S. AISI 316 L CARBON O-RING IN EPDM	U7K	4U030U7KXZ7	6	CERAMIC - CARBON O-RING IN E.P.D.M.	KL2A	4U030KL2AZCE	
		KL2A	4U030KL2AZYE			C5E	4U030C5EBVE	
		C5E	4U030C5EBGE		CERAMIC - CARBON O-RING IN °VITON	KL2A	4U030KL2AZCV	
	S.S. AISI 316 L CARBON O-RING IN °VITON	U7K	4U030U7KXZY			C5E	4U030C5EBVV	
		KL2A	4U030KL2AZYV		CERAMIC - CARBON O-RING IN P.T.F.E.	KL2A	4U030KL2AZCP	
		C5E	4U030C5EBGV			C5E	4U030C5EBVP	
	S.S. AISI 316 L CARBON O-RING IN P.T.F.E.	U7K	4U030U7KXZP		SILICON CARBIDE - CARBON O-RING IN E.P.D.M.	KL2A	-	
		KL2A	4U030KL2AZYP			SILICON CARBIDE - CARBON O-RING IN °VITON	KL2A	-
		C5E	4U030C5EBGP				SILICON CARBIDE - CARBON O-RING IN P.T.F.E.	KL2A
4	TUNGSTEN CARB. CARBON O-RING IN E.P.D.M.	U7K	4U030U7K3Z7	7	CERAMIC - RULON O-RING IN E.P.D.M.	C5E	4U030C5EYVE	
		KL2A	4U030KL2AKZE			CERAMIC - RULON O-RING IN °VITON	C5E	4U030C5EYVV
		C5E	4U030C5EBUE		CERAMIC - RULON O-RING IN P.T.F.E.		C5E	4U030C5EYVP
	TUNGSTEN CARB. CARBON O-RING IN °VITON	U7K	4U030U7K3ZY	8	SILICON CARBIDE SILICON CARBIDE O-RING IN E.P.D.M.	KL2A	4U030KL2AUUE	
		KL2A	4U030KL2AKZV			SILICON CARBIDE SILICON CARBIDE O-RING IN °VITON	KL2A	4U030KL2AUUV
		C5E	4U030C5EBUV				SILICON CARBIDE SILICON CARBIDE O-RING IN P.T.F.E.	KL2A
TUNGSTEN CARB. CARBON O-RING IN P.T.F.E.	U7K	4U030U7K3ZP	9		SILICON CARBIDE TUNGSTEN CARBIDE O-RING IN E.P.D.M.	KL2A	4U030KL2AUKE	
	KL2A	4U030KL2AKZP				SILICON CARBIDE TUNGSTEN CARBIDE O-RING IN °VITON	KL2A	4U030KL2AUKV
	C5E	4U030C5EBUP			SILICON CARBIDE TUNGSTEN CARBIDE O-RING IN P.T.F.E.		KL2A	4U030KL2AUKP
5 Q5	TUNGSTEN CARB. TUNGSTEN CARB. O-RING IN E.P.D.M.	U7K	4U030U7K337	9	SILICON CARBIDE TUNGSTEN CARBIDE O-RING IN E.P.D.M.	KL2A	4U030KL2AUKV	
		KL2A	4U030KL2AKKE			SILICON CARBIDE TUNGSTEN CARBIDE O-RING IN °VITON	KL2A	4U030KL2AUKP
		C5E	4U030C5EUUE				SILICON CARBIDE TUNGSTEN CARBIDE O-RING IN P.T.F.E.	KL2A
	TUNGSTEN CARB. TUNGSTEN CARB. O-RING IN °VITON	U7K	4U030U7K33Y		SILICON CARBIDE TUNGSTEN CARBIDE O-RING IN E.P.D.M.	KL2A		4U030KL2AUKV
		KL2A	4U030KL2AKKV			SILICON CARBIDE TUNGSTEN CARBIDE O-RING IN °VITON		KL2A
		C5E	4U030C5EUUV		SILICON CARBIDE TUNGSTEN CARBIDE O-RING IN P.T.F.E.		KL2A	4U030KL2AUKP
	TUNGSTEN CARB. TUNGSTEN CARB. O-RING IN P.T.F.E.	U7K	4U030U7K33P		9	SILICON CARBIDE TUNGSTEN CARBIDE O-RING IN P.T.F.E.	KL2A	4U030KL2AUKP
		KL2A	4U030KL2AKKP				KL2A	4U030KL2AUKP
		C5E	4U030C5EUUP				KL2A	4U030KL2AUKP

7.1.3 B215 B220 B325 B330 B390 B430 B440 B470 B490: Spare parts list

7.1.3.1 B215 B220 B325 B330 B390 B430 B440 B470 B490: Pump exploded view drawing

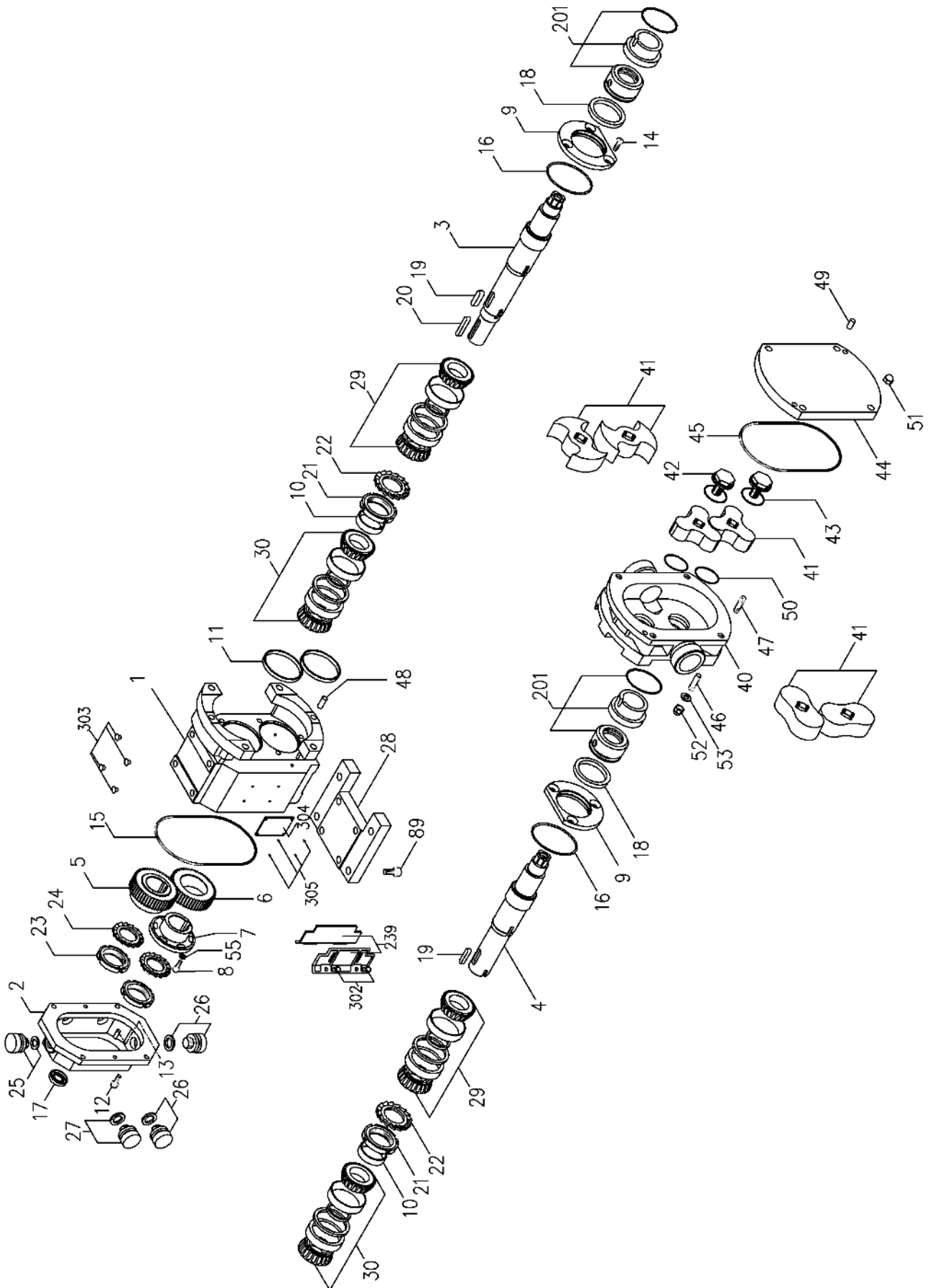

B2 B3 B4 B470 B490

7.1.3.2 B215 B220 B325 B330 B390 B430 B440 B470 B490: Spare parts names and codes

POS	DESCRIPTION	Q.TY	B215	B220	B325	B330	B390	B430	B440	B470	B490
1	BEARING BOX	1	2001G002			2001G003		2001G004		2001G008	
2	GEAR COVER	1	2001L032			2001L033		2001L034		2001L038	
3	SAI 316 L DRIVING SHAFT	1	2004B003	2004B004	2004B005	2004B006		2004B007	2004B008	2004B063	2004B065
3	DUPLEX DRIVING SHAFT	1	2004D003	2004D004	2004D005	2004D006		2004D007	2004D008	2004D009	2004D010
3	SAI 316 L DOUBLE MECH. SEAL DRIVING SHAFT	1	2004D017	2004D018	2004D019		-	2004D021	2004D022	2004D023	2004D024
4	SAI 316 L DRIVEN SHAFT	1	2004B031	2004B032	2004B033	2004B034		2004B035	2004B036	2004B064	2004B066
4	DUPLEX DRIVEN SHAFT	1	2004D031	2004D032	2004D033	2004D034		2004D035	2004D036	2004D037	2004D038
4	SAI 316 L DOUBLE MECH. SEAL DRIVING SHAFT	1	2004D047	2004D048	2004D049		-	2004D051	2004D052	2004D053	2004D054
5	FIXED GEAR	1	2008M002			2008M003		2008M004		2004M014	
6	ADJUSTABLE GEAR	1	2008M008			2008M009		2008M010		2008M015	
7	ADJUSTABLE GEAR BUSH	1	2008M032			2008M033		2008M034		2008M037	
8	SCREW	6	411A06X16			411A08X20		411A10X25		411A10X30	
9	SPLIT RING	2	2001C052			2001C053		2001C054		2001C057	
10	REAR AXIAL ADJUSTMENT SPACER	2	2014M021								
11	FRONT AXIAL ADJUSTMENT SPACER	2	2014M025			2014M026		2014M027		2014M044	
12	SCREW	4	411A08X20			411A08X25		411A10X30		411A10X30	
13	PIN	2	417A06X14			417A06X16		417A06X16		417A08X16	
14	SCREW	6	411A08X20S			411A08X20S		411A10X25S		411A10X25S	
15	GEAR COVER O-RING	1	404T4562			404T4675		404T4900		404T81050	
16	BEARING RETAINER O-RING	2	404T3268			404T4312		404T4437		404T4500	
17	OIL SEAL RING	1	403Y32457			403Y37528		403Y557210D		403Y658510D	
18	OIL SEAL RING	2	403Y45608D			403Y60758D		403Y801008D		403Y9011012D	
19	KEY	2	418F10X30M			418F12X40M		418F18X50M		418F20X60M	
20	KEY	1	418F08X40			418F10X50		418F14X70		418F16X90	
21	BEARING RING NUT	2	415F40			415F50		415F70		415F80	
22	WASHER	2	416F40			416F50		416F70		416F80	
23	GEAR RING NUT	2	415F35			415F40		415F60		415F70	
24	WASHER	2	416F35			416F40		416F60		416F70	
25	OIL VENT CAP	1	407L12S			407L12S		407L12S		407L12S	
26	OIL CAP	1	407L12T			407L12T		407L12T		407L12T	
27	OIL LEVEL	1	407L12L			407L12L		407L12L		407L12L	
28	HORIZONTAL FOOT	1	2001G102			2001G103		2001G104		2001G105	
29	FRONT BEARING (ASSEMBLED)	2	2019M002			2019M003		2019M004		2019M008	
30	REAR BEARING (ASSEMBLED)	2	2019M005			2019M002		2019M007		2019M004	

POS	DESCRIPTION	Q.TY	B215	B220	B325	B330	B390	B430	B440	B470	B490
31	VERTICAL FOOT	2	2001A302			2001A303		2001A304		2001A305	
32	SCREW FOR VERTICAL FOOT	8	411A10X20			411A12X25		411A14X30		411A20X40	
33	COUNTERFLANGE FOR ENLARGED INLET PORT	1	-	2006B046	-	2006B047	-	-	2006B048	-	2006B049
34	O-RING	1	-	404T4350	-	404T4500	-	-	404T4650	-	404T4725
40	PUMPING CASE	1	23....04	23....05	23....06	23....07	23....17	23....08	23....09	23....15	23....16
41	3-LOBE ROTOR S.S. AISI 316 L VERSIONE ST	1	2005B004	2005B005	2005B006	2005B007	2005B0096	2005B008	2005B009	2005B090	2005B092
41	2-LOBE S.S. AISI 316 L VERSION ST	2	2005B028	2005B029	2005B030	2005B031	-	2005B032	2005B033	2005B094	2005B095
41	3-LOBE ROTOR S.S. AISI 316 L VERSIONE SM	2	2005B016	2005B017	2005B018	2005B019	-	2005B020	2005B021	2005B046	2005B047
41	2-LOBE S.S. AISI 316 L VERSION SM	2	2005B040	2005B041	2005B042	2005B043	-	2005B044	2005B045	2005B048	2005B049
41	3-LOBE ROTOR (5-LOBE FOR B105) RUBBER COATED N.B.R.	2	2005B052	2005B053	2005B054	2005B055	-	2005B056	2005B057	-	-
41	3-LOBE ROTOR (5-LOBE FOR B105) RUBBER COATED E.P.D.M.	2	-	-	-	-	-	-	-	-	-
41	2-LOBE ROTOR RUBBER COATED N.B.R.	2	2005B064	2005B065	2005B066	2005B067	-	2005B068	2005B069	2005B096	2005B097
41	2-LOBE ROTOR RUBBER COATED E.P.D.M.	2	-	-	-	-	-	-	-	-	-
41	DUAL WING CY6SnBiM (antiscizzure) VERSION ST	2	2005&076	2005&77	2005&078	2005&079	-	2005&080	2005&081	2005&082	2005&083
41	3-LOBE ROTOR CY6SnBiM (antiscizzure) VERSION ST	2	2005&004	2005&005	2005&006	2005&007	-	2005&008	2005&009	-	-
42	LOCKING NUT FOR STANDARD ROTOR	2	2004B102		2004B103		2004B125	2004B104		2004B104	
43	LOCKING NUT O-RING	2	404T3118		404T3162		404T3162	404T3200		404T3200	
44	FRONT COVER	2	2006B002			2006B003		2006B004		2006B008	
45	COVER O-RING	2	404T4625			404T4750		404T81025		404T81175	
46	BACK STUD	4	419A10X41			419A12X46		419A16X55		419A20X70	
47	FRONT STUD	4(*)-8	419A10X41(*)			419A10X41		419A12X46		419A14X55	
48	BACK PIN	2	417A10X20			417A12X25		417A12X25		417A16X40	
49	FRONT PIN	2	417A08X16			417A08X16		417A08X16		417A10X20	
50	ROTOR O-RING	2	404T2106			404T3143		4043187		407T3187	
51	CAP NUT	4(*)-8	414A10(*)			414A10		414A12		414A14	
52	CAP NUT	4	414A10			414A12		414A16		414A20	
53	PLANE WASHER	4	412A10			412A12		412A16		412A20	
55	PLANE WASHER	12	412F06			412F08		412F10		412F10	
-	COMPLETE SAFETY VALVE	6	2013B002			2013B003		2013B004		2013B021	
56	SAFETY VALVE SUPPORT	1	2013L021			2013L022		2013L023		2013B047	
56/1	BUSH SAFETY VALVE SUPPORT	1	2013B040			2013B041		2013B042		2013B042	
57	SAFETY VALVE PISTON	1	2013B026			2013B027		2013B028		2013B048	

B2 B3 B4 B470 B490

POS	DESCRIPTION	Q.TY	B215	B220	B325	B330	B390	B430	B440	B470	B490
58	SAFETY VALVE COVER	1	2013L029			2013L029		2013L030		2013A027	
59	SAFETY VALVE ADJUSTMENT SCREW	1	2013B031			2013B031		2013B031		2013A028	
60	THRUST WASHER	1	2013L032			2013L032		2013L033		2013A026	
61	ADJUSTMEN RING NUT	1	2013A034			2013A034		2013A035		2013A038	
62	SAFETY VALVE ADJUSTMENT RETAINER	1	2013L036			2013L036		2013L036		2013A025	
63	SAFETY VALVE SCREW	1	411A06X20			411A08X35		411A10X40		411A08X50	
64	SAFETY VALVE COVER SCREW	4	411A06X55			411A06X55		411A08X60		411A08X70	
65	SCREW	4	420A06X06			420A06X06		420A06X06		420A06X06	
66	SPLIT RING (SEEGER)	2	421A381			421A381		421A521		421A631	
67	SPLIT RING (SEEGER)	1	421A16E			421A16E		421A16E		421A34E	
68	SAFETY VALVE PISTON O-RING	1	404T4200			404T6275		404T189		404T208	
69	SAFETY VALVE SUPPORT O-RING	1	404T3250			404T4337		404T4462		404T4600	
70	SAFETY VALVE LOCK	1	41106X10			411A06X10		411A06X10		418A20X56	
71	SPRING	1				see par. 7.1.6					
72	END COVER FOR SAFETY VALVE	1	2006B032			2006B033		2006B034		2006B029	
89	FOOT SCREW	4	411A10X25			411A12X35		411A14X35		411A20X50	
91	SAFETY VALVE SUPPORT	1	2013B039			2013B032		2013B036		2013B043	
92	SCREW	4	411A06X35			411A08X40		411A10X40		411A08X40	
93	SUPPORT O-RING	1	404T3250			404T4337		404T4462		404T4600	
94	PISTONE VALVOLA DI SICUREZZA PNEUMATICA	1	2013B030			2013B035		2013B038		2013B045	
95	KEY	1	418A14X30			418A14X30		418A14X30		418A18X50	
96	SAFETY VALVE O-RING	1	404T4200			404T6275		404T189		404T208	
97	ADJUSTMENT RING NUT	1	2013A034			2013A034		2013A034		2013A038	
98	SCREW	2	420A05X06			420A05X06		420A05X06		420A06X08	
99	PNEUMATIC SAFETY VALVE COVER	1	2013A032			2013A030		2013A031		2013A029	
100	PNEUMATIC SAFETY VALVE COVER BACK O-RING	1	404T4275			404T4275		404T4312		404T4425	
101	PNEUM. SAFETY VALVE COVER FRONT O-RING	1	404T4312			404T4312		404T4475		404T4600	
102	PISTON COVER O-RING	1	404T134			404T134		404T134		404T4131	
103	PNEUMATIC SAFETY VALVE JACKET	1	2013A035			2013A036		2013A037		2013A039	
104	SCREW	4-6(*)	411A06X110			411A08X130		411A10X130		411A08X130(*)	
105	THRUST RING	1	2013L024			2013L024		2013L025		2013L026	
106	PISTON ROD THRUST O-RING	1	404T119			404T119		404T119		404T4075	
107	THRUST JACKET O-RING	1	404T6300			404T6300		404T8450		404T8562	
108	RING NUT	2	415F20AUT			415F20AUT		415F20AUT		415F25AUT	

POS	DESCRIPTION	Q.TY	B215	B220	B325	B330	B390	B430	B440	B470	B490
111	END COVER FOR HEATING VERSION	1	2006B052			2006B053		2006B054		2006B057	
112	END COVER FOR ASEPTIC VERSION	1	2006B102			2006B103		2006B104		2006B105	
113	END COVER FOR JACKET	1	2006B162			2006B162		2006B164		2006B168	
114	SCREW	4-8(*)	411A06X20			411A06X20		411A06X20 (*)		411A08X25(**)	
115	END COVER JACKET O-RING	1	404T4500			404T4500		404T4750		404T4875	
116	ASEPTIC INTERNAL COVER O-RING	1	404V4625			404V4750		404V009		404T81150	
117	ASEPTIC EXTERNAL COVER O-RING	1	404V4675			404V4825		404V010		404T81250	
118	COUNTERFLANGE FOR ASEPTIC VERSION PUMPING CASE	2	2006B181	2006B182	2006B183		2006B184	2006B184	2006B185	2006B185	
119	INTERNAL O-RING FOR ASEPTIC VERSION	2	404V3168	404V3212	404V174		404V4325	404V4325	404V4426	404V4426	
120	EXTERNAL O-RING FOR ASEPTIC VERSION	2	404V3231	404V3275	404V4350		404V4412	404V4412	404V4525	404V4525	
121	SCREW	8 12(*) 16(**)	411A06X20		411A06X20(*)		411A08X25(*)	411A08X25(*)	411A08X35(**)	411A10X35(**)	
239	SEAL PROTECTION	2	4034Y002			4034Y003		4034Y004		4034Y007	
302	SEAL PROTECTION SCREW	4	410A05X10			410A05X10		410A05X10		410A05X10	
303	PLUG	4	44301022			44301023		44301024		44301025	
304	NAME PLATE	1	4034A100			4034A100		4034A100		4034A100	
305	RIVET	4	44301027			44301027		44301027		44301027	
306	EYEBOLT	2	-	-	-	-	-	-	-	-	-

7.1.3.3 B215 B220 B325 B330 B390 B430 B440 B470 B490: Seals section drawings

UM Lip Seal

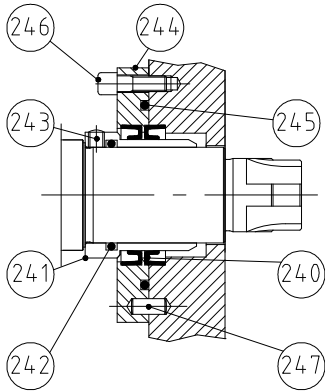

S1 Lip Seal

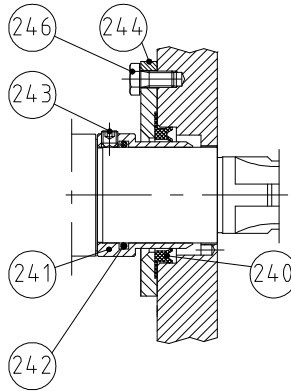

Packing Gland

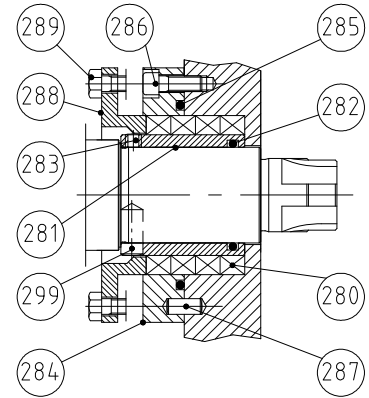

Packing Gland with liquid barrier

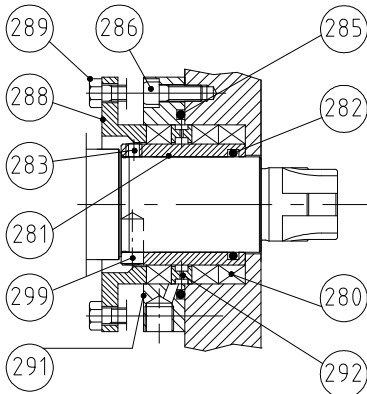

Single Mechanical Seal "U7K"

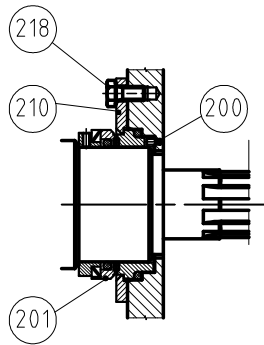

"KL2A"

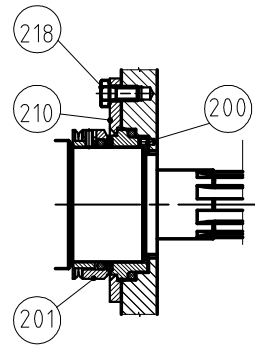

"C5E"

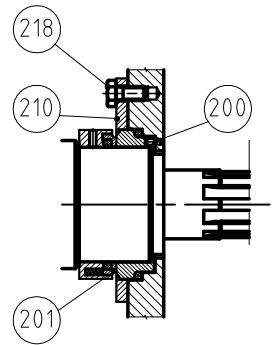

Double HN Lip Seal

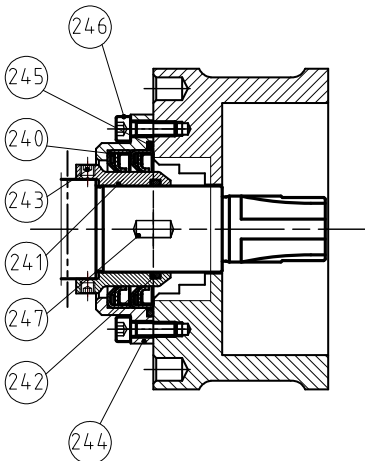

Single Flushed Mechanical Seal FLUSSATA "U7K", "KL2A", "C5E"

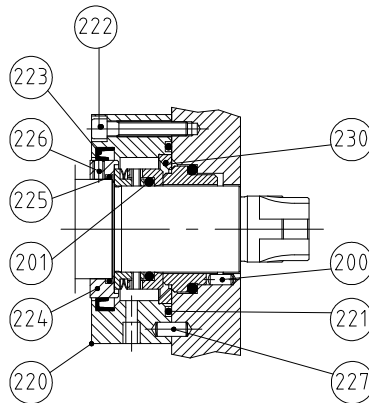

Double Mechanical Seal

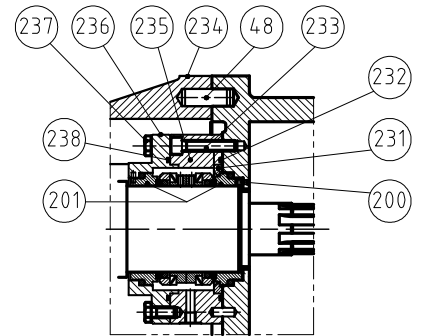

POS.	DESCRIPTION	Q.TY	B215 B220	B325 B330 B390	B430 B440	B470 B490
200	SEAL STOP PIN	2	2014B200	2014B200	2014B200	2014B200
201	SINGLE MECHANICAL SEAL	2	see par. 7.1.3.6			
210	BALANCING RING	2	see par. 7.1.3.5			
218	SCREW	6 - 8(*)	410A06X12	410A06X14	410A10X20	410A10X20(*)
220	FLUSHING SEAL BOX	2	2014B142	2014B143	2014B144	2014B159
221	O-RING	2	404T168	404T4312	404T4437	404T4500
222	SCREW	6 - 8(*)	411A06X35	411A06X40	411A10X40	411A10X50(*)
223	SEAL RING UM	2	402V705510	402V857010	402V1109510	402V13511012

B2 B3 B4 B470 B490

POS.	DESCRIPTION	Q.TY	B215 B220	B325 B330 B390	B430 B440	B470 B490
224	ROTATING RING	2	2004B152	2004B153	2004B154	2004B167
225	BUSH O-RING	6	404T3181	404T4237	404T4312	404T4350
226	GRANO DI FISSAGGIO ANELLO ROTANTE	6	420A05X05	420A05X05	420A06X06	420A06X08
227	SPINA	4	417A06X12	417A06X12	417A08X15	417A08X15
230	BALANCING RING U7K (SINGLE MECH. SEAL)	2	see par. 7.1.3.6			
231	BALANCING RING U7K (DOUBLE MECH. SEAL)	2	see par. 7.1.3.5			
232	O-RING	2	404T168	404T4312	404T4437	-
233	SCREW	6-8(*)	411A06X40	411A06X50	411A10X45	411A10X55
234	BEARING BOX FOR DOUBLE SEALS	1	2001G162	2001G163	2001G164	2001G165
235	FLUSHING BOX FOR DOUBLE SEAL	2	2014B148	2014B149	2014B150	2014B151
236	COVER	2	2014B154	2014B155	2014B156	2014B157
237	SCREW	4	410A06X18	410A06X16	410A10X20	410A10X20
238	O-RING	2	404T165	404T4312	404T4412	404T4500
239	SEAL PROTECTION	2	4034Y002	4034Y003	4034Y004	4034A007
240	UM LIP SEAL IN °VITON (F.K.M.)	4	402V48405	402V705510	402V857010	402V1058510
240	UM LIP SEAL IN E.P.D.M.	4	402U48405	402U705510	402U857010	402U1058510
240	S1 LIP SEAL	2	402Q48406	402Q70558	402Q857010	402Q1158510
240	DOUBLE HN LIP SEAL	4	402HN42608	402HN55728	402HN8010010	402HN85X110X10
241	ROTATING BUSH FOR UM / S1 LIP SEAL	2	2004B157	2004B158	2004B159	2004B168
241	ROTATING BUSH FOR HN SEAL	2	2004B192	2004B193	2004B194	2004B198
242	BUSH O-RING FOR UM / S1 LIP SEAL	2	404T3137	404T4200	404T168	404T181
242	BUSH O-RING FOR HN LIP SEAL	2	404T149	404T4237	404T168	404T181
243	UM / S1 PIN	6	420A06X06	420A06X06	420A06X06	420A08X10
243	HN PIN	6	420A05X05	420A05X05	420A06X06	420A08X10
244	UM SUPPORT	2	2014B052	2014B053	2014B054	2014B057
244	S1 SUPPORT	2	2014B062	2014B063	2014B064	2014B066
244	HN SUPPORT	2	2014B112	2014B113	2014B114	2014B116
245	UM O-RING SUPPORT	2	404T168	404T4312	404T4437	404T4500
245	HN O-RING SUPPORT	2	404T168	404T4312	404T4437	404T4500
246	UM SUPPORTSCREW	6	410A06X12	41006X25	410A10X25	410A10X30
246	S1 SUPPORT SCREW	6	410A06X12	410A06X14	410A10X25	410A10X16
246	SCREW FOR HN LIP SEAL FLANGE	6	410A06X20	410A06X20	410A10X25	410A10X25
247	PIN FOR HN LIP SEAL FLANGE	4	417A06X12	417A06X16	417A08X16	417A08X16
247	FOR UM LIP SEAL FLANGE	4	-	417A06X16	417A08X15	417A08X16
280	KIT PACKING GLAND IN P.T.F.E.	1	205P45576	205P60768	205P80968	205P10012010
281	STUFFING BOX SEAL SUPPORT	2	2004B162	2004B163	2004B164	2004B169
282	ROTATING BUSH O-RING	2	404T4137	404T4200	404T168	404T181
283	SCREW	6	420A06X05	420A06X06	420A06X06	420A08X08
284	STUFFING BOX SEAL SUPPORT	2	2014B072	2014B073	2014B074	2014B083
285	FLANGE SUPPORT O-RING	2	404T168	404T4312	404T4437	404T4500
286	SCREW	3	411A06X16	411A06X20	411A10X16	411A10X25
287	PIN	4	417A06X12	417A06X12	417A08X16	417A08X16
288	PACKING GLAND ADJUSTER	2	2014B102	2014B103	2014B104	2014B107
289	SCREW	2	410A06X20	410A08X20	410A10X25	410A10X25
290	KIT PACKING GLAND IN P.T.F.E. WITH LIQUID BARRIER	1	201P45576	201P60768	201P80968	201P10012010
291	FLUSHED STUFFING BOX SEAL SUPPORT	2	2014B078	2014B079	2014B080	2014B084
292	HYDRAULIC RING	2	2014B122	2014B123	2014B124	2014B126
295	SPACER	2	-	-	-	-
296	MECHANICAL SEAL SUPPORT	2	-	-	-	-
297	SUPPORT O-RING	2	-	-	-	-
298	SCREW	4	-	-	-	-
299	PIN	2	430A05X10	430A06X12	430A08X18	430A08X20

B2 B3 B4 B470 B490

7.1.3.4 B215 B220 B325 B330 B390 B430 B470 B490: Gasket or ring codes for mechanical seals

MECHANICAL SEAL MATERIALS	RING TYPE	RING MODEL	B215 B220 DIAMETER 35	B325 B330 B390 DIAMETER 50	B430 B440 DIAMETER 65	B470 B490 DIAMETER 80
S.S. AISI 316 L CARBON	ROTANTING	U7K	404U4137	404U4200	404U6262	404U181
		KL2A			404U65X4.5	404U80X4.5
		C5E			404U168	404U181
	STATIONARY	U7K	404U147	404U6237	404U6300	404U92X7
		KL2A			404U61X4.65	404U76X4.65
		C5E				404U94X6
TUNGSTEN CARBIDE CARBON	ROTANTING	U7K	404U4137	404U4200	404U6262	404U181
		KL2A			404U65X4.5	404U80X4.5
		C5E			404U168	-
	STATIONARY	U7K	404U147	404U6237	404U6300	404U92X7
		KL2A			404U61X4.65	404U76X4.65
		C5E				-
TUNGSTEN CARBIDE TUNGSTEN CARBIDE	ROTANTING	U7K	404U4137	404U4200	404U6262	404U181
		KL2A			404U65X4.5	404U93X6
		C5E			404U168	-
	STATIONARY	U7K	404U147	404U6237	404U6300	404U92X7
		KL2A			404U61X4.65	404U76X4.65
		C5E				-
CERAMIC CARBON	ROTANTING	KL2A	404U4137	404U4200	-	-
		C5E			404U168	404U181
	STATIONARY	KL2A	404U147	404U61X4.65	-	-
		C5E			404U76X4.65	404U94X6
SILICON CARBIDE CARBON	ROTANTING	KL2A	-	-	404U65X4.5	404U80X4.5
	STATIONARY		-	-	404U76X4.65	404U93X6
CERAMIC RULON	ROTANTING	C5E	404U4137	404U4200	404U168	404U181
	STATIONARY		404U147	404U61X4.65	404U76X4.65	404U94X6
SILICON CARBIDE SILICON CARBIDE	ROTANTING	KL2A	404U4137	404U4200	404U65X4.5	404U80X4.5
	STATIONARY		404U147	404U61X4.65	404U76X4.65	404U93X6
SILICON CARBIDE TUNGSTEN CARBIDE	ROTANTING	KL2A	404U4137	404U4200	404U65X4.5	404U80X4.5
	STATIONARY		404U147	404U6237	404U6300	404U93X6

7.1.3.5 B215 B220 B325 B330 B390 B430 B470 B490: Balancing ring codes for single and flushed mechanical seals

MECHANICAL SEAL MATERIAL	MATERIAL CODE	STATIONARY RING	RING MODEL	B215 B220		B325 B330 B390		B430 B440		B470 B490	
				SINGLE SEAL	FLUSHED SEAL	SINGLE SEAL	FLUSHED SEAL	SINGLE SEAL	FLUSHED SEAL	SINGLE SEAL	FLUSHED SEAL
S.S. AISI 316 L CARBON	3	CARBON	U7K	2014B002	2014B008	2014B003	2014B009	2014B004	2014B010	2014B018	2014B019
		SS.AISI316L	KL2A	2014B222	2014B232	2014B223	2014B233	2014B224	2014B234	2014B236	2014B237
		SS.AISI316L	C5E								
TUNGST. CARB. CARBON	4	CARBON	U7K	2014B002	2014B008	2014B003	2014B009	2014B004	2014B010	2014B018	2014B019
		TUNGST.CARBIDE	KL2A								
		TUNGST.CARBIDE	C5E	2014B216	2014B242	2014B217	2014B243	2014B218	2014B244	-	-
TUNGST. CARB. TUNGST. CARB.	5	TUNGST.CARBIDE	U7K	2014B002	2014B008	2014B003	2014B009	2014B004	2014B010	2014B018	2014B019
		TUNGST.CARBIDE	KL2A								
		TUNGST.CARBIDE	C5E	2014B216	2014B242	2014B217	2014B243	2014B218	2014B244	-	-
CERAMIC CARBON	6	CERAMIC	KL2A	2014B222	2014B232	2014B223	2014B233	-	-	-	-
			C5E					2014B224	2014B234	2014B236	2014B237
SILICON CARB. CARBON	A	SILICON CARBID	KL2A	-	-	-	-	2014B224	2014B234	2014B236	2014B237
CERAMIC RULON	7	CERAMICA	C5E	2014B222	2014B232	2014B223	2014B233	2014B224	2014B234	-	-
SILICON CARB. SILICON CARB.	8	SILICON CARBID	KL2A	2014B222	2014B232	2014B223	2014B233	2014B224	2014B234	2014B236	2014B237
SILICON CARB. TUNGST. CARB.	9	TUNGST.CARBIDE	KL2A	2014B002	2014B008	2014B003	2014B009	2014B004	2014B010	2014B018	2014B019

7.1.3.6 B215 B220 B325 B330 B390 B430 B440 B470 B490: Single and double mechanical seals codes

COD.	SEAL MATERIAL	SEAL MODEL	B215 B220	B325 B330 B390	B430 B440	B470 B490
3 Q3	S.S. AISI 316 L / CARBON O-RING IN EPDM	U7K	4U035U7KXZ7	4U050U7KXZ7	4U065U7KXZ7	4U080U7KXZ7
		KL2A	4U035KL2AXZY	4U050KL2AXZY	4U065KL2AXZY	4U080KL2AXZY
		C5E	4U035C5EBGE	4U050C5EBGE	4U065C5EBGE	4U080C5EBGE
	S.S. AISI 316 L / CARBON O-RING IN °VITON	U7K	4U035U7KXZY	4U050U7KXZY	4U065U7KXZY	4U080U7KXZY
		KL2A	4U035KL2AZYV	4U050KL2AZYV	4U065KL2AZYV	4U080KL2AZYV
		C5E	4U035C5EBGV	4U050C5EBGV	4U065C5EBGV	4U080C5EBGV
	S.S. AISI 316 L / CARBON O-RING IN P.T.F.E.	U7K	4U035U7KXZP	4U050U7KXZP	4U065U7KXZP	4U080U7KXZP
		KL2A	4U035KL2AZYP	4U050KL2AZYP	4U065KL2AZYP	4U080KL2AZYP
		C5E	4U035C5EBGP	4U050C5EBGP	4U065C5EBGP	4U080C5EBGP
4	TUNGSTEN CARBIDE / CARBON O-RING IN E.P.D.M.	U7K	4U035U7K3Z7	4U050U7K3Z7	4U065U7K3Z7	4U080U7K3Z7
		KL2A	4U035KL2AKZE	4U050KL2AKZE	4U065KL2AKZE	4U080KL2AKZE
		C5E	4U035C5EBUE	4U050C5EBUE	4U065C5EBUE	-
	TUNGSTEN CARBIDE / CARBON O-RING IN °VITON	U7K	4U035U7K3ZY	4U050U7K3ZY	4U065U7K3ZY	4U080U7K3ZY
		KL2A	4U035KL2AKZV	4U050KL2AKZV	4U065KL2AKZV	4U080KL2AKZV
		C5E	4U035C5EBUV	4U050C5EBUV	4U065C5EBUV	-
	TUNGSTEN CARBIDE / CARBON O-RING IN P.T.F.E.	U7K	4U035U7K3ZP	4U050U7K3ZP	4U065U7K3ZP	4U080U7K3ZP
		KL2A	4U035KL2AKZP	4U050KL2AKZP	4U065KL2AKZP	4U080KL2AKZP
		C5E	4U035C5EBUP	4U050C5EBUP	4U065C5EBUP	-
5 Q5	TUNGSTEN CARBIDE / TUNGSTEN CARBIDE O-RING IN E.P.D.M.	U7K	4U035U7K337	4U050U7K337	4U065U7K337	4U080U7K337
		KL2A	4U035KL2AKKE	4U050KL2AKKE	4U065KL2AKKE	4U080KL2AKKE
		C5E	4U035C5EUUE	4U050C5EUUE	4U065C5EUUE	-
	TUNGSTEN CARBIDE / TUNGSTEN CARBIDE O-RING IN °VITON	U7K	4U035U7K33Y	4U050U7K33Y	4U065U7K33Y	4U080U7K33Y
		KL2A	4U035KL2AKKV	4U050KL2AKKV	4U065KL2AKKV	4U080KL2AKKV
		C5E	4U035C5EUUV	4U050C5EUUV	4U065C5EUUV	-
	TUNGSTEN CARBIDE / TUNGSTEN CARBIDE O-RING IN P.T.F.E.	U7K	4U035U7K33P	4U050U7K33P	4U065U7K33P	4U080U7K33P
		KL2A	4U035KL2AKKP	4U050KL2AKKP	4U065KL2AKKP	4U080KL2AKKP
		C5E	4U035C5EUUP	4U050C5EUUP	4U065C5EUUP	-
6	CERAMIC / CARBON O-RING IN E.P.D.M.	KL2A	4U035KL2AZCE	4U050KL2AZCE	-	-
		C5E	4U035C5EBVE	4U050C5EBVE	4U065C5EBVE	4U080C5EBVE
	CERAMIC CARBON O-RING IN °VITON	KL2A	4U035KL2AZCV	4U050KL2AZCV	-	-
		C5E	4U035C5EBVV	4U050C5EBVV	4U065C5EBVV	4U080C5EBVV
	CERAMICA CARBON O-RING IN P.T.F.E.	KL2A	4U035KL2AZCP	4U050KL2AZCP	-	-
		C5E	4U035C5EBVP	4U050C5EBVP	4U065C5EBVP	4U080C5EBVP
	SILICON CARBIDE / CARBON O-RING IN E.P.D.M.	KL2A	-	-	4U065KL2AZUE	4U080KL2AZUE
SILICON CARBIDE / CARBON O-RING IN °VITON	KL2A	-	-	4U065KL2AZUV	4U080KL2AZUV	
SILICON CARBIDE / CARBON O-RING IN P.T.F.E.	KL2A	-	-	4U065KL2AZUP	4U080KL2AZUP	
7	CERAMIC / RULON O-RING IN E.P.D.M.	C5E	4U035C5EYVE	4U050C5EYVE	4U065C5EYVE	-
	CERAMIC / RULON O-RING IN °VITON	C5E	4U035C5EYVV	4U050C5EYVV	4U065C5EYVV	-
	CERAMIC / RULON O-RING IN P.T.F.E.	C5E	4U035C5EYVP	4U050C5EYVP	4U065C5EYVP	-
8	SILICON CARBIDE / SILICON CARBIDE O-RING IN E.P.D.M.	KL2A	4U035KL2AUUE	4U050KL2AUUE	4U065KL2AUUE	4U080KL2AUUE
	SILICON CARBIDE / SILICON CARBIDE O-RING IN °VITON	KL2A	4U035KL2AUUV	4U050KL2AUUV	4U065KL2AUUV	4U080KL2AUUV
	SILICON CARBIDE / SILICON CARBIDE O-RING IN P.T.F.E.	KL2A	4U035KL2AUUP	4U050KL2AUUP	4U065KL2AUUP	4U080KL2AUUP
9	SILICON CARBIDE / TUNGSTEN CARBIDE O-RING IN E.P.D.M.	KL2A	4U035KL2AUKE	4U050KL2AUKE	4U065KL2AUKE	4U080KL2AUKE
	SILICON CARBIDE / TUNGSTEN CARBIDE O-RING IN °VITON	KL2A	4U035KL2AUKV	4U050KL2AUKV	4U065KL2AUKV	4U080KL2AUKV
	SILICON CARBIDE / TUNGSTEN CARBIDE O-RING IN P.T.F.E.	KL2A	4U035KL2AUKP	4U050KL2AUKP	4U065KL2AUKP	4U080KL2AUKP

7.1.4 B550 B660 B680: Spare parts list

7.1.4.1 B550 B660 B680: Pump exploded view drawing

B550 Exploded view drawing

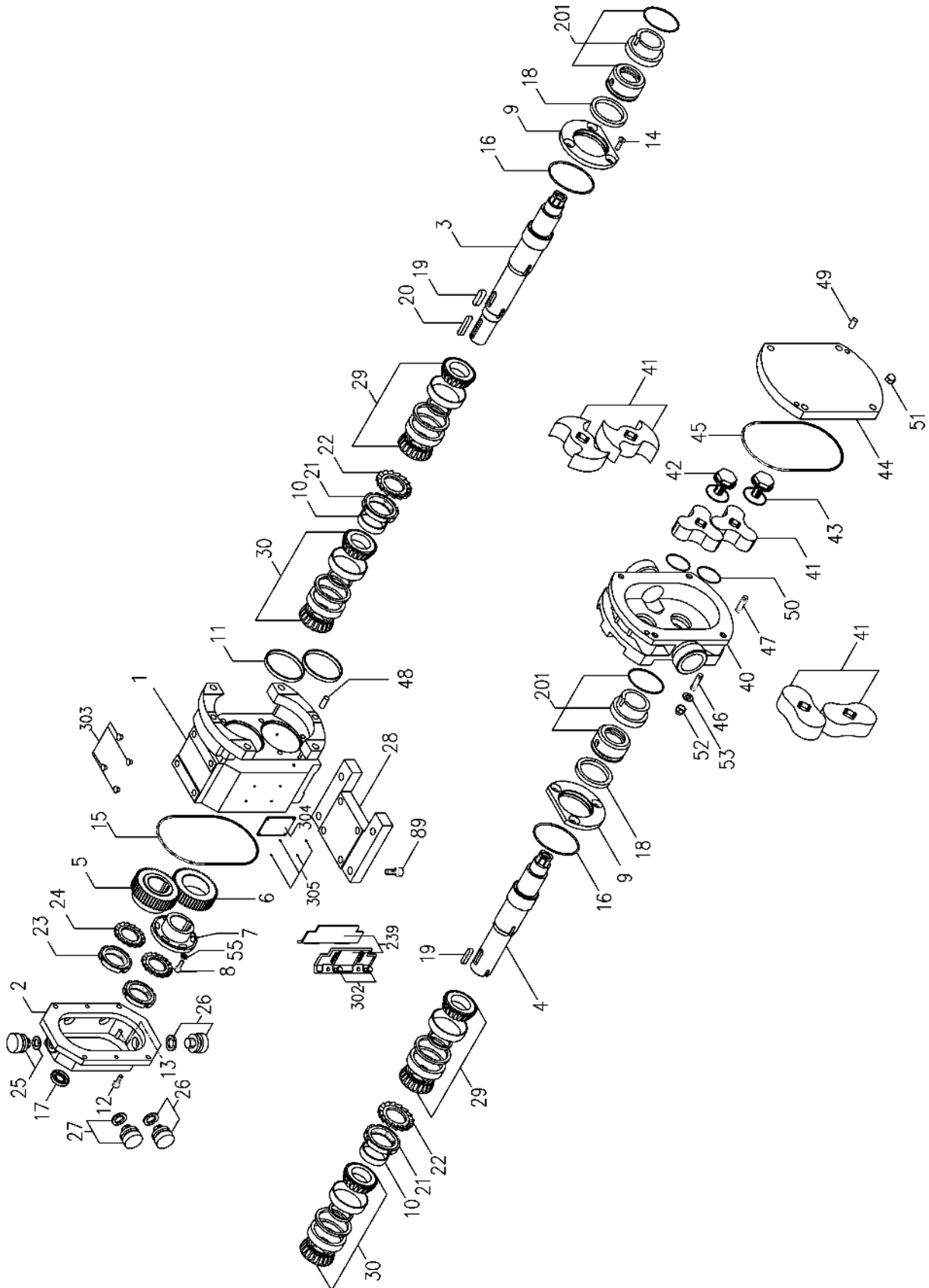

B660 B680 Exploded view drawing

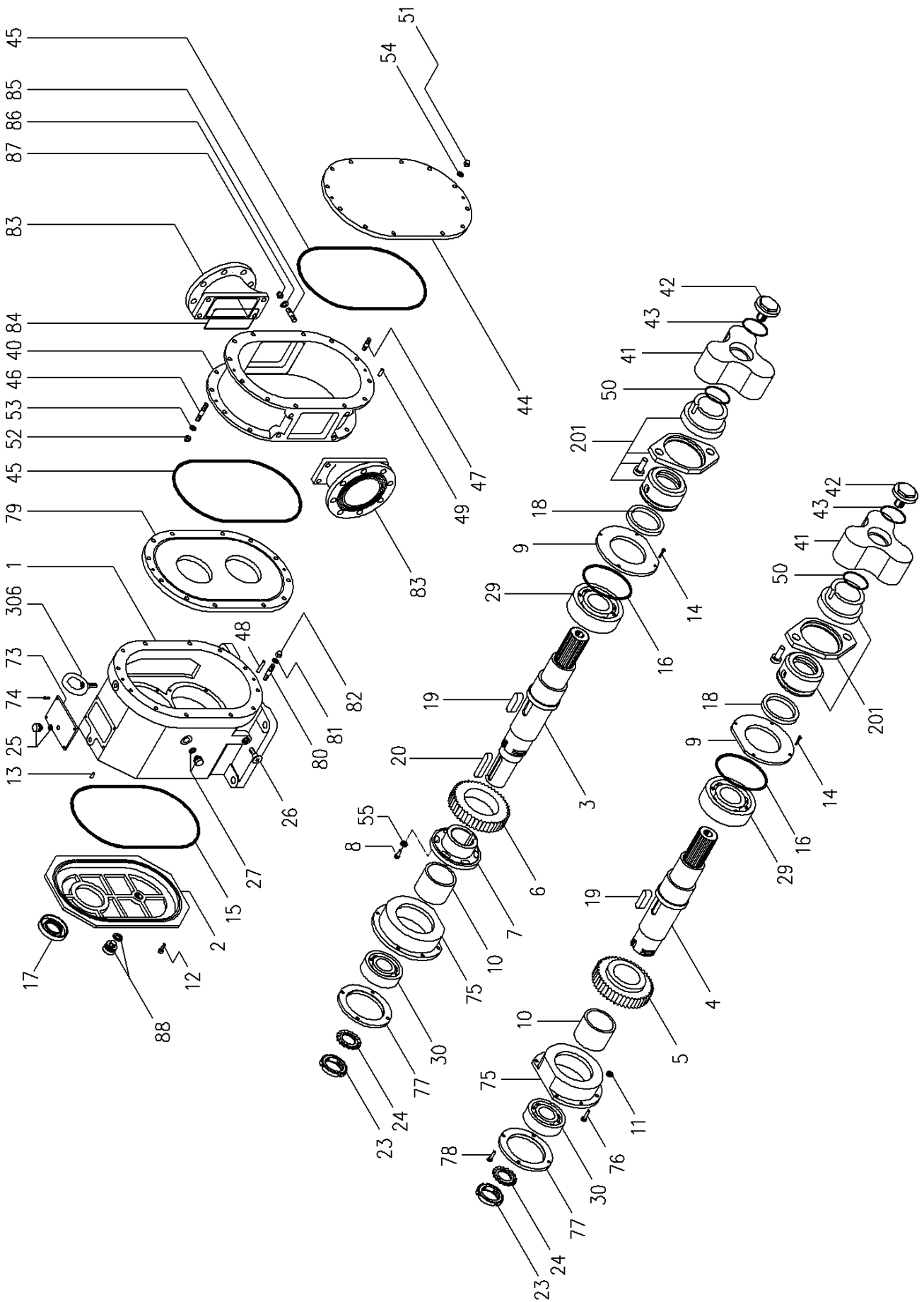

B550 B660 B680

7.1.4.2 B550 B660 B680: Spare parts names and codes

POS	DESCRIPTION	Q.TY	B550	B660	B680
1	BEARING BOX	1	2001G005	2001G006	
2	GEAR COVER	1	2001G035	2001G036	
3	AISI 316 L DRIVING SHAFT	1	2004B010	2004B011	2004B012
3	DUPLEX DRIVING SHAFT	1	-	2004D011	-
4	AISI 316 L DRIVEN SHAFT	1	2004B038	2004B039	2004B040
4	DUPLEX DRIVEN SHAFT	1	-	2004D039	
5	FIXED GEAR	1	2008M005	2008M006	
6	ADJUSTABLE GEAR	1	2008M011	2008M012	
7	ADJUSTABLE GEAR BUSH	1	2008035	2008M036	
8	SCREW	6	410A12X35	410A16X45	
9	SPLIT RING	2	2001C055	2001C056	
10		2	2014M022	2014M023	
11	AXIAL ADJUSTMENT SPACER	8	2014M028	2014M029	
12	SCREW	4	411A08X20	411A10X30	
13	PIN	2	417A08X16	417A10X30	
14	SCREW	6	411A08X20	411A10X30	
15	GEAR COVER O-RING	1	404T001	404T002	
16	BEARING RETAINER O-RING	2	404T4562	404T4875	
17	OIL SEAL RING	1	403Y609010	403Y9012012	
18	OIL SEAL RING	2	403Y8011010D	403Y12015012D	
19	KEY	2	418F20X60M	418F28X80M	
20	KEY	1	418F16X90	418F22X120	
23	GEAR RING NUT	2	415F70	415F100	
24	WASHER	2	416F70	416F100	
25	OIL VENT CAP	1	407L12S	407L12S	
26	OIL CAP	1	407L38T	407L12T	
27	OIL LEVEL	1	407L34L	407L1L	
29	FRONT BEARING (ASSEMBLED)	2	406FNJ2216E	406FNJ224	
30	REAR BEARING (ASSEMBLED)	2	406F3214	406F3220	
40	PUMPING CASE	1	23....11	23....12	23....13
41	3-LOBE ROTOR S.S.AISI 316 L VERSION ST	2	2005B011	2005B012	2005B013
41	2-LOBE ROTOR S.S.AISI 316 L VERSION ST	2	2005B035	2005B036	2005B037
41	3-LOBE ROTOR S.S.AISI 316 L VERSION SM	2	2005B023	2005B024	2005B025
41	2-LOBE ROTOR S.S. AISI 316 L VERSION SM	2	2005B102	2005B048	2005B049
41	RUBBER COATED 3-LOBE ROTOR BUNA-N.B.R.	2	2005B059	2005B060	2005B061
41	RUBBER COATED 3-LOBE ROTOR E.P.D.M.	2	2005B071	2005B072	2005B073
41	RUBBER COATED 2-LOBE ROTOR BUNA-N.B.R.	2	-	-	-
41	RUBBER COATED 2-LOBE ROTOR E.P.D.M.	2	-	-	-
41	DUAL WING CY5SnBIM (ANTISEIZURE) VERSION ST	2	2005&084	2005&085	-
41	3-LOBE ROTOR CY5SnBIM (ANTISEIZURE) VERSION ST	2	2005&011	2005&012	2005&013
41	3-LOBE ROTOR CY5SnBIM VERSIONE ST	2	2005B011	2005B012	2005B013
41	2-LOBE ROTOR CY5SnBIM VERSIONE ST	2	2005B035	2005B036	2005B037
41	3-LOBE ROTOR CY5SnBIM VERSIONE SM	2	2005B023	2005B024	2005B025
41	2-LOBE ROTOR CY5SnBIM VERSIONE SM	2	2005B102	2005B048	2005B049

POS	DESCRIPTION	Q.TY	B550	B660	B680
42	LOCKING NUT FOR STANDARD ROTOR	2	2004B105	2004B106	
43	LOCKING NUT O-RING	2	404T3225	404T4350	
44	FRONT COVER	1	2006B005	2006B006	
45	COVER O-RING	1	404T003	404T61900	
46	BACK STUD	4	419A14X53	419A14X85	
47	FRONT STUD	8 12(*)	419A21X46	419A14X52	
48	BACK PIN	2	417A14X30	417A10X55	
49	FRONT PIN	2	417A14X30	417A10X30	
50	ROTOR O-RING	2	404T3200	404T4312	
51	CAP NUT	8 12(*)	414A12	414A14	
52	CAP NUT	4	414A14	414A14	
53	PLANE WASHER	4	412A14	412A14	
54	PLANE WASHER	12	412A12	412A14	
55	PLANE WASHER	6	412F12	412F16	
73	INSPECTION COVER	1	2001L221	2001L222	
74	SCREW	4	411A06X16	411A06X16	
75	BEARING SUPPORT	2	2001G150	2001G151	
76	SCREW	8	411A10X30	411A12X40	
77	BACKBULL RING	2	2001F201	2001F202	
78	SCREW	8	411A10X30	411A12X35	
79	SEAL FLANGE	1	-	2006B132	
80	STUD	8	-	419A14X75	
81	PLANE WASHER	8	-	412A14	
82	CAP NUT	8	-	414A14	
83	FLANGED PORT	2	-	2006B152	2006B153
84	PORT O-RING	2	-	404T005	404T8850
85	SCREW	8	-	419A16X60	
86	PLANE WASHER	8	-	412A16	
87	CAP NUT	8	-	414A16	
88	OIL CLOSE CAP	1	407L34T	407L1T	
111	END COVER FOR HEATING VERSION	1	2006B055	2006B056	
113	END COVER FOR JACKET	1	2006B168	2006B166	
114	SCREW	4	411A08X25	411A08X25	
115	END COVER JACKET	1	4004T8975	404T81400	
302	SCREW	4	410A06X16	410A06X16	
304	NAME PLATE	1	4034A100	4034A100	
305	RIVET	4	44301027	44301027	
306	EYEBOLT	2	432F12	432F16	

7.1.4.3 B550 B660 B680: Seals section drawings

Seals section drawing B550

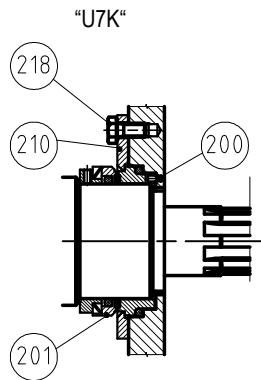
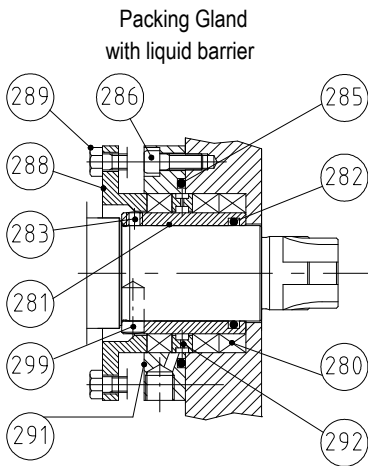
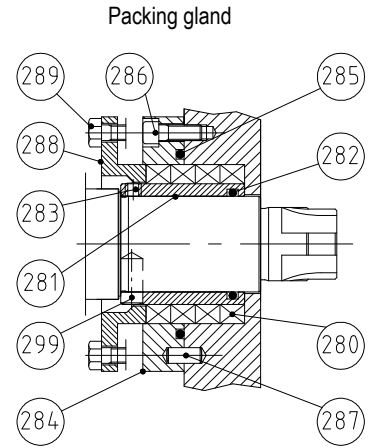
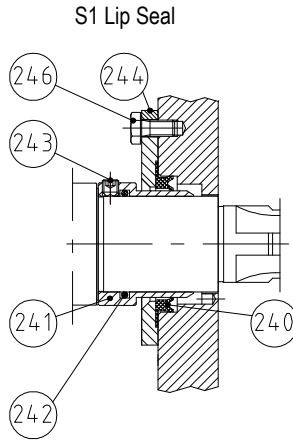
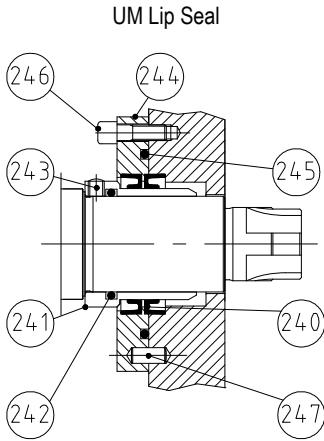

Single Mechanical Seal

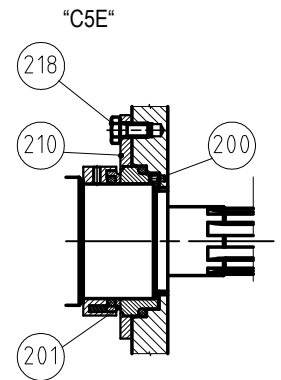
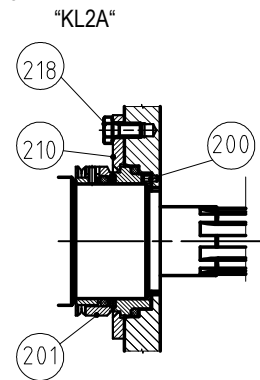

Double HN Lip Seal
"KL2A", "U7K", "C5E"

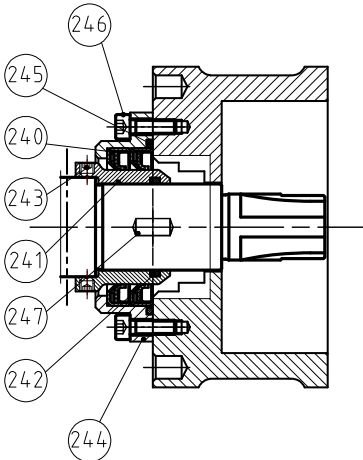

Single Mechanical
Flushed "KL2A", "U7K", "C5E"

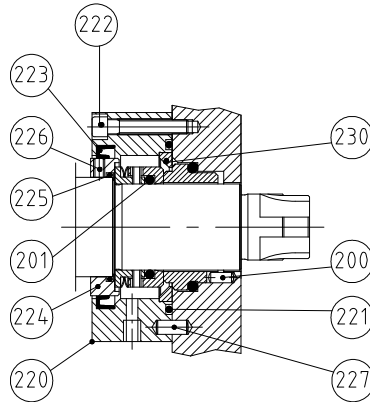

Double Mechanical Seal

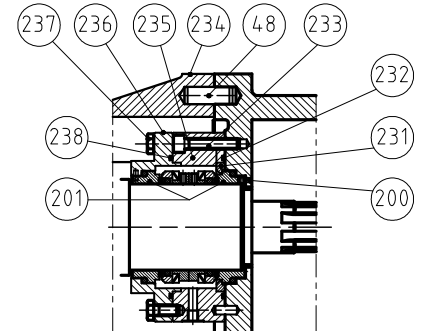

Seals section drawing B660 B680

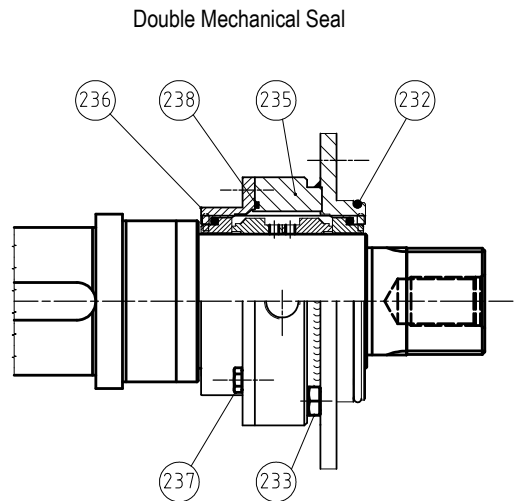
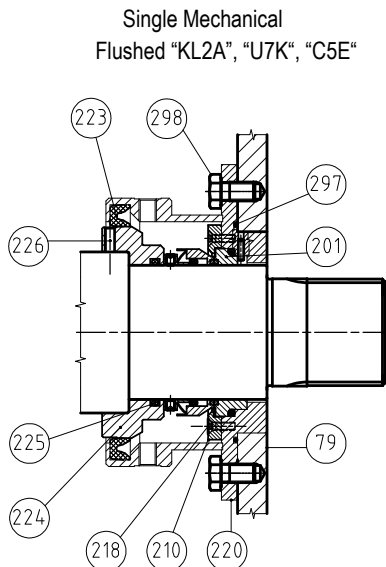
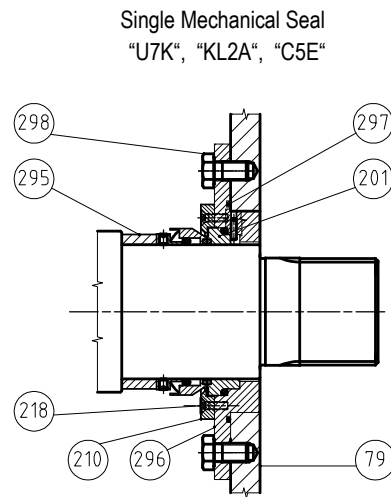
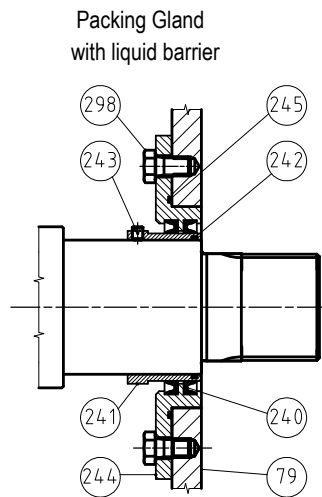
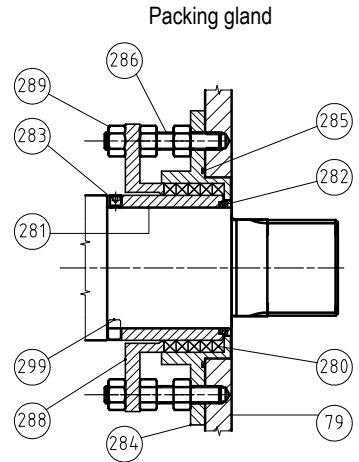
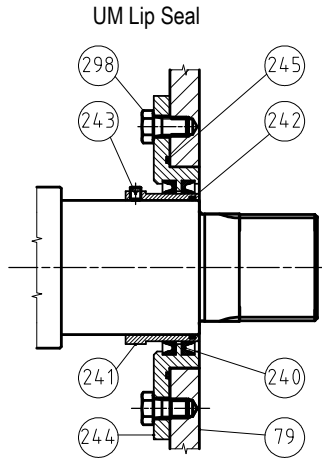

B550 B660 B680

POS.	DESCRIPTION	Q.TY	B550	B660	B680
200	SEAL STOP PIN	2	2014B200	-	-
201	SINGLE MECHANICAL SEAL	2	see par. 7.1.4.6		
210	BALANCING RING	2	see par. 7.1.4.5		
218	SCREW	12	410A10X20	411A06X20S	
220	FLUSHING SEAL BOX	2	2014B144	2014B164	
221	O-RING	2	404T4437	404T4625	
222	SCREW	12	411A10X40	-	
223	SEAL RING UM	2	402V1109510	402U19016015	
224	ROTATING RING	2	2004B166	2004B155	
225	BUSH O-RING	6	404T4312	404T4475	
226	GRANO DI FISSAGGIO ANELLO ROTANTE	6	420A08X06	420A08X12	
227	SPINA	4	417A08X15	-	
230	BALANCING RING U7K (SINGLE MECH. SEAL)	2	see par. 7.1.4.5		
231	BALANCING RING U7K (DOUBLE MECH. SEAL)	2	see par. 7.1.4.5		
232	O-RING	2	404T4437	404T215	
233	SCREW	6	-	410A14X30	
234	BEARING BOX FOR DOUBLE SEALS	1	-	-	
235	FLUSHING BOX FOR DOUBLE SEAL	2	2014B160	2014B152	
236	COVER	2	2014B162	2014B158	
237	SCREW	4	410A10X20	410A10X20	
238	O-RING	2	404T4437	404T4562	
239	SEAL PROTECTION	2	4034A008	4034A006	
240	UM LIP SEAL IN °VITON (F.K.M.)	4	402V857010	402V13011010	
240	UM LIP SEAL IN E.P.D.M.	4	402U857010	402U13011010	
240	S1 LIP SEAL	2	402Q857010	402Q13011010	
240	DOUBLE HN LIP SEAL	4	-	-	
241	ROTATING BUSH FOR UM / S1 LIP SEAL	2	2004B159	2004B160	
241	ROTATING BUSH FOR HN SEAL	2	-	-	
242	BUSH O-RING FOR UM / S1 LIP SEAL	2	404T168	404T4400	
242	BUSH O-RING FOR HN LIP SEAL	2	-	-	
243	UM / S1 PIN	6	420A06X06	420A08X10	
243	HN PIN	6	-	-	
244	UM SUPPORT	2	2014B054	2014B056	
244	S1 SUPPORT	2	2014B064	-	
244	HN SUPPORT	2	404T4437	-	
245	UM O-RING SUPPORT	2	410A10X25	404T4625	
245	HN O-RING SUPPORT	2	410A10X25	-	
246	UM SUPPORTSCREW	6	-	410A14X20	
246	S1 SUPPORT SCREW	6	-	-	
246	SCREW FOR HN LIP SEAL FLANGE	6	-	-	
247	PIN FOR HN LIP SEAL FLANGE	4	417A08X15	-	
247	FOR UM LIP SEAL FLANGE	4	-	-	
280	KIT PACKING GLAND IN P.T.F.E.	1	205P80968	205P11013412	
281	STUFFING BOX SEAL SUPPORT	2	2004B164	2004B165	
282	ROTATING BUSH O-RING	2	404T168	404T4400	
283	SCREW	6	420A06X06	420A08X10	
284	STUFFING BOX SEAL SUPPORT	2	2014B074	2014B076	
285	FLANGE SUPPORT O-RING	2	404T4437	404T4625	
286	SCREW	3	411A10X16	419A14X110	
287	PIN	4	417A08X16	-	
288	PACKING GLAND ADJUSTER	2	2014B104	2014B106	
289	SCREW	2	410A10X25	413A14	

POS.	DESCRIPTION	Q.TY	B550	B660	B680
290	KIT PACKING GLAND IN P.T.F.E. WITH LIQUID BARRIER	1	201P80968	201P11013412	
291	FLUSHED STUFFING BOX SEAL SUPPORT	2	2014B080	2014B082	
292	HYDRAULIC RING	2	2014B124	2014B125	
295	SPACER	2	2014B131	2014B132	
296	MECHANICAL SEAL SUPPORT	2	-	2014B092	
297	SUPPORT O-RING	2	-	404T4625	
298	SCREW	4	-	410A14X20	
299	PIN	2	430A08X18	430A08X18	

7.1.4.4 B550 B660 B680: Gasket or ring codes for mechanical seals

MECHANICAL SEAL MATERIAL	RING TYPE	RING MODEL	B550 DIAMETER 65	B660 B680 DIAMETER 100
S.S. AISI 316 L CARBON	ROTATING	U7K	404U6262	404U189
		KL2A	404U65X4.5	
		C5E	404U168	
	STATIONARY	U7K	404U6300	404U8450
		KL2A	404U76X4.65	404U6450
		C5E		-
TUNGSTEN CARBIDE CARBON	ROTATING	U7K	404U6262	-
		KL2A	404U65X4.5	404U189
		C5E	404U168	-
	STATIONARY	U7K	404U6300	-
		KL2A		404U6450
		C5E	404U76X4.65	-
TUNGSTEN CARBIDE TUNGSTEN CARBIDE	ROTATING	U7K	404U6262	404U189
		KL2A	404U65X4.5	
		C5E	404U168	
	STATIONARY	U7K	404U6300	404U8450
		KL2A		404U6450
		C5E	404U76X4.65	-
CERAMIC CARBON	ROTATING	KL2A	-	-
		C5E	404U168	-
	STATIONARY	KL2A	-	-
		C5E	404U76X4.65	-
SILICON CARBIDE CARBON	ROTATING	KL2A	404U65X4.5	404U189
	STATIONARY		404U76X4.65	404U6450
CERAMIC RULON	ROTATING	C5E	404U168	-
	STATIONARY		404U76X4.65	-
SILICON CARBIDE SILICON CARBIDE	ROTATING	KL2A	404U65X4.5	404U189
	STATIONARY		404U76X4.65	404U6450
SILICON CARBIDE TUNGSTEN CARBIDE	ROTATING	KL2A	404U65X4.5	404U189
	STATIONARY		404U6300	404U6450

7.1.4.5 B550 B660 B680: Balancing ring codes for single and flushed mechanical seals

MECHANICAL SEAL MATERIAL	MATERIAL CODE	STATIONARY RING	RING MODEL	B550		B660 B680	
				SINGLE SEAL	FLUSHED SEAL	SINGLE SEAL	FLUSHED SEAL
S.S. AISI 316 L CARBON	3	CARBON	U7K	2014B004	2014B010	2014B006	2014B006
		SS.AISI316L	KL2A	2014B224	2014B234	2014011	2014B011
		SS.AISI316L	C5E			-	-
TUNGSTEN CARB. CARBON	4	CARBON	U7K	2014B004	2014B010	-	-
		TUNGSTEN CARBIDE	KL2A			2014B006	2014B006
		TUNGSTEN CARBIDE	C5E	2014B218	2014B244	-	-
TUNGSTEN CARB. TUNGSTEN CARB.	5	TUNGSTEN CARBIDE	U7K	2014B004	2014B010	2014B021	2014B021
		TUNGSTEN CARBIDE	KL2A			-	-
		TUNGSTEN CARBIDE	C5E	2014B218	2014B244	-	-
CERAMIC CARBON	6	CERAMIC	KL2A	-	-	-	-
			C5E	2014B224	2014B234	-	-
SILICON CARBIDE CARBON	A	SILICON CARBIDE	KL2A	2014B224	2014B234	2014B011	2014B011
CERAMIC RULON	7	CERAMIC	C5E	2014B224	2014B234	-	-
SILICON CARBIDE SILICON CARBIDE	8	SILICON CARBIDE	KL2A	2014B224	2014B234	2014B011	2014B011
SILICON CARBIDE TUNGSTEN CARB.	9	TUNGSTEN CARBIDE	KL2A	2014B004	2014B010	2014B011	2014B011

7.1.4.6 B550 B660 B680: Single and double mechanical seals codes

COD.	SEAL MATERIAL	SEAL MODEL	B550	B660 B680
3 Q3	S.S. AISI 316 L / CARBON O-RING IN EPDM	U7K	4U065U7KXZ7	-
		KL2A	4U065KL2AXZY	4U100KL2AXZY
		C5E	4U065C5EBGE	-
	S.S. AISI 316 L / CARBON O-RING IN "VITON	U7K	4U065U7KXZY	-
		KL2A	4U065KL2AZYV	4U100KL2AZYV
		C5E	4U065C5EBGV	-
	S.S. AISI 316 L / CARBON O-RING IN P.T.F.E.	U7K	4U065U7KXZP	-
		KL2A	4U065KL2AZYP	4U100KL2AZYP
		C5E	4U065C5EBGP	-
4	TUNGSTEN CARBIDE / CARBON O-RING IN E.P.D.M.	U7K	4U065U7K3Z7	-
		KL2A	4U065KL2AKZE	4U100KL2AKZE
		C5E	4U065C5EBUE	-
	TUNGSTEN CARBIDE / CARBON O-RING IN "VITON	U7K	4U065U7K3ZY	-
		KL2A	4U065KL2AKZV	4U100KL2AKZV
		C5E	4U065C5EBUV	-
	TUNGSTEN CARBIDE / CARBON O-RING IN P.T.F.E.	U7K	4U065U7K3ZP	-
		KL2A	4U065KL2AKZP	4U100KL2AKZP
		C5E	4U065C5EBUP	-
5 Q5	TUNGSTEN CARBIDE / TUNGSTEN CARBIDE O-RING IN E.P.D.M.	U7K	4U065U7K337	4U100U7K337
		KL2A	4U065KL2AKKE	4U100KL2AKKE
		C5E	4U065C5EUUE	-
	TUNGSTEN CARBIDE / TUNGSTEN CARBIDE O-RING IN "VITON	U7K	4U065U7K33Y	4U100U7K33Y
		KL2A	4U065KL2AKKV	4U100KL2AKKV
		C5E	4U065C5EUUV	-
	TUNGSTEN CARBIDE / TUNGSTEN CARBIDE O-RING IN P.T.F.E.	U7K	4U065U7K33P	-
		KL2A	4U065KL2AKKP	4U100KL2AKKP
		C5E	4U065C5EUUP	-

COD.	SEAL MATERIAL	SEAL MODEL	B550	B660 B680
6	CERAMIC / CARBON O-RING IN E.P.D.M.	KL2A	-	-
		C5E	4U065C5EBVE	-
	CERAMIC / CARBON O-RING IN °VITON	KL2A	-	-
		C5E	4U065C5EBVV	-
	CERAMIC / CARBON O-RING IN P.T.F.E.	KL2A	-	-
		C5E	4U065C5EBVP	-
	SILICON CARBIDE / CARBON O-RING IN E.P.D.M.	KL2A	4U065KL2AZUE	4U100KL2AZUE
SILICON CARBIDE / CARBON O-RING IN °VITON	KL2A	4U065KL2AZUV	4U100KL2AZUV	
SILICON CARBIDE / CARBON O-RING IN P.T.F.E.	KL2A	4U065KL2AZUP	4U100KL2AZUP	
7	CERAMIC / RULON O-RING IN E.P.D.M.	C5E	4U065C5EYVE	-
	CERAMIC / RULON O-RING IN °VITON	C5E	4U065C5EYVV	-
	CERAMIC / RULON O-RING IN P.T.F.E.	C5E	4U065C5EYVP	-
8	SILICON CARBIDE / SILICON CARBIDE O-RING IN E.P.D.M.	KL2A	4U065KL2AUUE	4U100KL2AUUE
	SILICON CARBIDE / SILICON CARBIDE O-RING IN °VITON	KL2A	4U065KL2AUUV	4U100KL2AUUV
	SILICON CARBIDE / SILICON CARBIDE O-RING IN P.T.F.E.	KL2A	4U065KL2AUUP	4U100KL2AUUP
9	SILICON CARBIDE / TUNGSTEN CARBIDE O-RING IN E.P.D.M.	KL2A	4U065KL2AUKE	4U100KL2AUKE
	SILICON CARBIDE / TUNGSTEN CARBIDE O-RING IN °VITON	KL2A	4U065KL2AUKV	4U100KL2AUKV
	SILICON CARBIDE / TUNGSTEN CARBIDE O-RING IN P.T.F.E.	KL2A	4U065KL2AUKP	4U100KL2AUKP

7.1.5 Name and codes of pumping bodies

This naming refers to position n. 40 (pumping body) of the construction exploded view drawings in sections 7.1.1.1, 7.1.2.1, 7.1.3.1, 7.1.4.1 and identifies the item code to order as a spare part.

Example: code 23102B07

2	3	1	0	2	B	0	7
A	B	C	D	E	F	G	G

Code 23102B07 identifies the finished body, with heated chamber, for mechanical seals, for DIN11851 openings, made of AISI 316 L material, for the size of the LDPU.

The code of the pump bodies is made up as follows:

A	B	C	D	E	F	G	G
---	---	---	---	---	---	---	---

A	CODIFY	2 = FINISHED PART	5 = SEMIFINISHED PART	6 = CAST PART
---	--------	-------------------	-----------------------	---------------

B	FAMIGLIA	3 = FAMILY MEMBERSHIP		
---	----------	-----------------------	--	--

C	VERSION	0 = STANDARD	1 = HEATED PUMP BODY	2 = ASEPTIC	3 = HEATED ASEPTIC
		4 = HIGH PRESSURE	5 = HIGH PRESSURE + HEATED PUMP BODY	6 = ENLARGED INLET PORT	7 = ENLARGED INLET PORT + HEATED PUMP BODY

D	HOUSING TYPE SEALS	0 = MECHANICAL AND LIP SEAL	1 = PACKING GLAND SEAL	9 = SPECIAL
---	-----------------------	-----------------------------	------------------------	-------------

E	CONNECTIONS	0 = THREAD GAS-BSP	1 = FLANGE PN 16 UNI2278	2 = DIN11851	3 = SMS	4 = RJT
		5 = IDF-ISS	6 = TRI-CLAMP	7 = GAS	8 = ENOLOGIC	9 = SPECIAL

F	MATERIAL	B	H	I	J	R
---	----------	---	---	---	---	---

G-G	Numerical order in relation to the size					
-----	---	--	--	--	--	--

7.1.6 Codes of the springs used in the mechanical safety valve

The table below lists the identification codes of the springs used in the mechanical safety valves (see ref. section 3.3.3), codes that can be used to order any spare parts.

PUMP	SPRING CODE		
	B100	(0 ÷ 5 bar) code 422F015	(6 ÷ 10 bar) code 422F016
B105 B110 B115	(0 ÷ 13 bar) code 422F001	(14 ÷ 17 bar) code 422F011	(18 ÷ 20 bar) code 422F002
B215 B220	(0 ÷ 13 bar) code 422F001	(14 ÷ 17 bar) code 422F011	(18 ÷ 20 bar) code 422F002
B325 B330 B390	(0 ÷ 7 bar) code 422F003	(8 ÷ 13 bar) code 422F011	(14 ÷ 17 bar) code 422F005
B430 B440	(0 ÷ 7 bar) code 422F017	(8 ÷ 11 bar) code 422F004	(12 ÷ 17 bar) code 422F008
B470 B490	(0 ÷ 7 bar) code 422F013	(8 ÷ 15 bar) code 422F014	-

7.1.7 Codes of the springs used in the external bridge mechanical safety valve

The table below lists the kinds of springs used in the external bridge mechanical safety valves (see ref. section 3.3.3): depending on the adjustment pressure and valve diameter one can recognise the spring identification letter: "A", "B", "C", "D", "E".

VALVE DIMENSION	PRESSURE (BAR)				
	SPRING "A"	SPRING "B"	SPRING "C"	SPRING "D"	SPRING "E"
DN 25	0.5 ÷ 2 bar	1 ÷ 3.5 bar	1 ÷ 6.5 bar	1 ÷ 9 bar	1 ÷ 10 bar
DN 32	0.5 ÷ 2 bar	1 ÷ 3.5 bar	1 ÷ 6.5 bar	1 ÷ 9 bar	1 ÷ 10 bar
DN 40	0.5 ÷ 2 bar	1 ÷ 3.5 bar	1 ÷ 6.5 bar	1 ÷ 9 bar	1 ÷ 10 bar
DN 50		0.5 ÷ 2 bar	1 ÷ 3.7 bar	1 ÷ 6 bar	1 ÷ 10 bar
DN 65			0.5 ÷ 2 bar	0.5 ÷ 3.3 bar	1 ÷ 7.7 bar
DN 80			0.5 ÷ 1.7 bar	0.5 ÷ 2.3 bar	1 ÷ 5 bar
DN 100				0.5 ÷ 1.3 bar	0.5 ÷ 4 bar

7.2 Recommended spare parts

It is advisable for the Customer, in order to ensure the shortest plant down time, to stock up on spare parts relating to sealing parts complete with gaskets.

The codes relating to these components can be found in sections 7.1.1.3 - 7.1.1.4 - 7.1.2.3 - 7.1.2.4 - 7.1.2.6 - 7.1.3.3 - 7.1.3.4 - 7.1.3.6 - 7.1.4.3 - 7.1.4.4 - 7.1.4.6, depending on the size of the B Series lobe displacement pump, part of the LDPU.

7.3 How to order spare parts

With reference to the previous sections, the single parts that compose the LDPU are marked with an internal O.M.A.C. code.

This code is of vital importance when communicating with our spare parts department.

In order to have the spare parts delivered quickly you must communicate the following data to us, even via a purchase order:

- machine model (*)
- serial number (*)
- component description
- component reference code (refer to the attachments of the manual)
- desired amount.

(*) information that can be found on the machine, on the nameplate

Contacts:

- Tel.: 0522/629371 or 0522/629923 and ask for the "spare parts" department
- Fax: 0522/628980
- E-mail: info@omacpompe.com

CHAPTER 8: ASSISTANCE

O.M.A.C. S.r.l. has a customer after-sales assistance service that can solve any problem in relation to the LDPU.
In the case there are anomalies in the lobe pumps used, contact our after-sales assistance service which will see to solve the problem.

Contacts:

- Tel.: 0522/629371 or 0522/629923 and ask for the "assistance" department
- Fax: 0522/628980
- E-mail: info@omacpompe.com

Only O.M.A.C. S.r.l. technical personnel is qualified to carry out extraordinary maintenance activities that the LDPU requires.





CHAPTER 9: WARRANTY

O.M.A.C. S.r.l. grants a warranty for twenty-four months from the date of delivery for new LDPU's that have been subjected to normal work of eight hours a day, while if they will be subjected to a double or triple work shift, during the day, the warranty term will be respectively reduced by half (in the case of a double work shift) or by a third (in the case of a triple work shift).

Unless otherwise agreed, the warranty is only for new LDPU's manufactured by the seller and used as described in the attached technical sheet, thus excluding LDPU's used in unintended manners, overhauled LDPU's and those parts of LDPU's built by other companies for which the warranties of the respective manufacturers apply (electrical panel, bridge By-Pass, etc.).

The warranty consists in repairing or replacing all pieces that are possibly defective in terms of materials or processing, returned free port to the headquarters of OMAC s.r.l.

The warranty does not extend to failures resulting from improper installation, inexperience in the running the LDPU, from poor maintenance, negligence, when changes have been made to the LDPU or non-original spare parts have been used, without the written consent of OMAC s.r.l. .

Electrical components are always excluded from the warranty.

Under no circumstances can the manufacturer be charged for damages due to non-compliance with our requirements, or manipulations carried out by untrained personnel. Under no circumstances can we replace for free those pieces whose failure or breakage depends on normal wear and tear, misuse, or in inappropriate use conditions or use of the LDPU other than what was agreed in the sale contract.

Any assistance required during the warranty period must be carried out solely by OMAC s.r.l. skilled technicians. In the case this LDPU is used for abrasive/corrosive products, this warranty is reduced to 2 months.

If the LDPU is tampered with by unauthorised personnel the warranty is voided.

All repairs or replacements of pieces for failures not attributable to manufacture defects or poor quality of the material will be charged in full to the Customer.



AVVERTENZA:

An installation other than that indicated in chapter, a use other than that indicated in chapter 4, the possible seizure of rotors, caused by foreign bodies, such as pipe process scraps, welding cinders, dust, etc. will void the warranty.



OMAC



O.M.A.C. S.R.L.
Via G. Falcone nr. 8 – 42048 RUBIERA (RE) – ITALY (UE)
Tel. 0522/629371 – 629923 / Fax. 0522/628980
WebSite: www.omacpompe.com E-mail: info@omacpompe.com

