

Operation and Maintenance Manual

BA and BB Series

size 100 105 110 115 215 220 325 330 390 430 440 470 490

BF Series

size 100 105 110 115 215 220 325 330

Lobe Positive Displacement Group Pump Unit

Translation from the Original Instructions

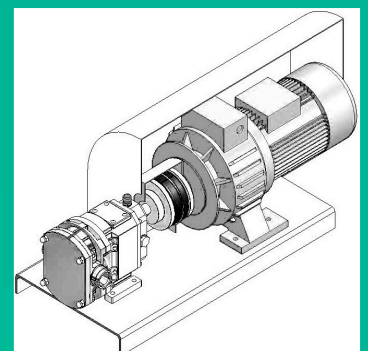



© Copyright by
O.M.A.C. s.r.l.
Via Giovanni Falcone, 8
42048 RUBIERA (RE) – ITALY
Printed directly by the company
Revision 1 - January 2011



SUMMARY

<i>INTENDED USE</i>	VII
<i>EC DECLARATION OF CONFORMITY (EXAMPLE)</i>	IX
<i>HOW TO CONSULT AND KEEP THIS DOCUMENTATION</i>	XI
<i>SYMBOLS USED</i>	XI
<i>KEEPING THE MANUAL</i>	XI
<i>LABLES APPLIED</i>	XII
<i>TERMS AND DEFINITIONS</i>	XII

CHAPTER 1: MACHINE AND PUMPED FLUID SPECIFICATIONS

1.1 Envisioned duration	Chap.1-pag.1
1.2 Technical description of the machine	Chap.1-pag.1
1.2.1 Operation principle of the LPDP	Chap.1-pag.1
1.2.2 BA BB BF Series lobe positive displacement pump coding	Chap.1-pag.2
1.3 Technical features	Chap.1-pag.4
1.3.1 Technical features of the LPDPG	Chap.1-pag.5
1.3.2 Variation of maximum operating pressure according to temperature	Chap.1-pag.5
1.3.3 Motorization and transmission coupling technical features	Chap.1-pag.6
1.3.4 Rotors clearances	Chap.1-pag.6
1.3.5 Rotors geometry	Chap.1-pag.6
1.3.6 Tightening torque	Chap.1-pag.7
1.3.7 Mechanical seals overall dimensions	Chap.1-pag.7
1.3.8 Weights and dimensions table of the LPDPG	Chap.1-pag.8
1.3.9 Dimensions of the heating/cooling rotorcase connections and of the flushing seals connections	Chap.1-pag.10
1.3.10 Suction inlet dimensions in "widened rectangular inlet" version of the LPDP	Chap.1-pag.10
1.3.11 Bearings	Chap.1-pag.11
1.3.12 Lubricants used and quantities	Chap.1-pag.11
1.4 Intended use	Chap.1-pag.11
1.4.1 Recommended use guidelines for the transfer of some types of processed fluid	Chap.1-pag.12
1.5 Material specifications	Chap.1-pag.14
1.6 Occupied workplaces	Chap.1-pag.14
1.7 Indication of the safety systems	Chap.1-pag.14
1.7.1 Flexible transmission coupling protection	Chap.1-pag.15
1.7.2 Emergency stop	Chap.1-pag.15
1.7.3 Seals protections	Chap.1-pag.15
1.7.4 Optional features: full fairing	Chap.1-pag.15
1.7.5 Optional features: Electric safety devices and pressure limiters	Chap.1-pag.15
1.8 Noise and vibrations emitted	Chap.1-pag.16
1.10 Personnel training	Chap.1-pag.16
1.11 LPDP optional features	Chap.1-pag.16
1.11.1 LPDP in aseptic version	Chap.1-pag.16
1.11.2 LPDP with widened rectangular inlet	Chap.1-pag.17
1.11.3 LPDP with rotorcase cavity and rotorcase cover cavity	Chap.1-pag.17
1.11.4 LPDP with mechanical safety valve on rotorcase cover	Chap.1-pag.17
1.11.5 LPDP with pneumatic safety valve on the rotorcase cover	Chap.1-pag.18
1.11.6 LPDP with external mechanical bridge safety valve	Chap.1-pag.18
1.12 LPDPG optional features	Chap.1-pag.18
1.12.1 Motorized LPDPG on fixed base	Chap.1-pag.18
1.12.2 Motorized LPDPG on trolley base	Chap.1-pag.18

CHAPTER 2: TRANSPORTATION

2.1 Hoisting and transportation	Chap.2-pag.1
2.2 Delivery and unpacking	Chap.2-pag.2
2.3 Conditions for storage or extended interruptions of service	Chap.2-pag.2
2.4 Packaging composition for future handling	Chap.2-pag.3

CHAPTER 3: INSTALLATION

3.1 Destination an intended environments	Chap.3-pag.1
3.2 Environmental conditions	Chap.3-pag.1
3.2.1 Room lighting	Chap.3-pag.1
3.3 Installation and assembly	Chap.3-pag.1

SUMMARY

3.3.1 Notes for the installer	Chap.3-pag.2
3.3.2 Preliminary checks	Chap.3-pag.2
3.3.3 Installation	Chap.3-pag.2
3.3.4 Accessories fitting	Chap.3-pag.5
3.4 Cleaning and hygiene of the LPDPG	Chap.3-pag.9
3.4.1 LDPU for alimentary use	Chap.3-pag.9
3.4.1.1 External cleaning instructions	Chap.3-pag.10
3.4.1.2 Internal cleaning instructions	Chap.3-pag.10
3.4.1.2.1 Internal cleaning: CIP (Cleaning In Place)/SIP (Sterilising In Place)	Chap.3-pag.10
3.4.1.2.2 Internal cleaning: manual cleaning	Chap.3-pag.11
3.4.2 LPDPG for chemical use	Chap.3-pag.11
3.4.2.1 External cleaning instructions	Chap.3-pag.12
3.4.2.2 Internal cleaning instructions	Chap.3-pag.12
3.4.2.2.1 Internal cleaning: CIP (Cleaning In Place)	Chap.3-pag.13
3.4.2.2.2 Internal cleaning: manual cleaning	Chap.3-pag.13
3.5 Connection to energy sources	Chap.3-pag.14
3.5.1 Connection to the electrical system	Chap.3-pag.14
3.5.2 Connection to the hydraulic system	Chap.3-pag.14
3.5.3 Connection to the pneumatic system	Chap.3-pag.15
3.6 Use of lubricants	Chap.3-pag.16
3.7 Installation and pre-start check: operation test	Chap.3-pag.16
CHAPTER 4: USE	Chap.4-pag.1
4.1 Intended use	Chap.4-pag.1
4.2 Controls	Chap.4-pag.2
4.3 LDPU volumetric capacity adjustment methods	Chap.4-pag.3
4.3.1 Adjustment of the volumetric capacity with the inverter	Chap.4-pag.3
4.3.2 Adjustment of volumetric capacity via mechanical speed controller	Chap.4-pag.3
4.4 Work cycle description	Chap.4-pag.4
4.5 Cycle start instructions	Chap.4-pag.4
4.5.1 Preliminary operations: check list	Chap.4-pag.4
4.5.2 First start-up	Chap.4-pag.5
4.6 Stopping instructions	Chap.4-pag.5
4.7 Instructions for restarting after a stop	Chap.4-pag.5
4.8 Switch-off	Chap.4-pag.5
4.9 Emptying	Chap.4-pag.5
4.10 Residual risks	Chap.4-pag.6
4.11 Dangers generated by use	Chap.4-pag.6
4.12 Prohibited use	Chap.4-pag.6
4.13 Management of emergency situations	Chap.4-pag.6
CHAPTER 5: MAINTENANCE	Chap.5-pag.1
5.1 Troubleshooting and solving problems	Chap.5-pag.1
5.2 Instruction for carrying out checks	Chap.5-pag.4
5.2.1 Daily checks	Chap.5-pag.4
5.2.2 Weekly checks	Chap.5-pag.5
5.2.3 Six monthly checks	Chap.5-pag.5
5.3 Periodic checks of the safety and emergency devices	Chap.5-pag.5
5.4 Indication of dangerous temperature	Chap.5-pag.5
5.5 Oils present	Chap.5-pag.5
5.6 Tests and checks	Chap.5-pag.5
5.6.1 Lubrication	Chap.5-pag.5
5.6.2 Single mechanical seals	Chap.5-pag.5
5.6.3 Mechanical seals with flushing	Chap.5-pag.5
5.6.4 Mechanical seals balancing	Chap.5-pag.6
5.7 Disassembly and assembly operations of BA BB BF100 size pump	Chap.5-pag.7
5.7.1 Disassembly of the pumping body	Chap.5-pag.8
5.7.2 Assembly of the pumping body	Chap.5-pag.8



SUMMARY

5.7.3 Disassembly of the bearing box	Chap.5-pag.9
5.7.4 Assembly of the bearing box	Chap.5-pag.9
5.8 Disassembly and assembly operations of BA BB BF 1 / BA BB BF 2 / BA BB BF 3 / BA BB / BA BB 470 / BA BB 490 size pump	Chap.5-pag.11
5.8.1 Disassembly of the rotorcase	Chap.5-pag.13
5.8.2 Assembly of the rotorcase	Chap.5-pag.13
5.8.3 Disassembly of the bearings box	Chap.5-pag.13
5.8.4 Assembly of the bearings box	Chap.5-pag.14
5.9 Post maintenance check	Chap.5-pag.16
CHAPTER 6: DECOMMISSIONING	Chap.6-pag.1
6.1 Disconnection from the sources of energy	Chap.6-pag.1
6.2 Disassembly	Chap.6-pag.2
6.3 Storage after its use	Chap.6-pag.2
6.4 Demolition and disposal	Chap.6-pag.2
CHAPTER 7: SPARE PARTS	Chap.7-pag.1
7.1 List of spare parts and section drawings of the lobe displacement pump	Chap.7-pag.1
7.1.1 BA BB BF Size 100: Spare parts list	Chap.7-pag.2
7.1.1.1 Pump exploded view drawing	Chap.7-pag.2
7.1.1.2 Spare parts names and codes	Chap.7-pag.3
7.1.1.3 Seals section drawings and spare parts	Chap.7-pag.4
7.1.2 BA BB BF Size 105 B110 B115: Spare parts list	Chap.7-pag.5
7.1.2.1 Pump exploded view drawing	Chap.7-pag.5
7.1.2.2 Spare parts names and codes	Chap.7-pag.6
7.1.2.3 Seals section drawings and spare parts	Chap.7-pag.10
7.1.3 BA BB BF Size 215 - 220: Spare parts list	Chap.7-pag.11
7.1.3.1 Pump exploded view drawing	Chap.7-pag.11
7.1.3.2 Spare parts names and codes	Chap.7-pag.12
7.1.3.3 Seals section drawings and spare parts	Chap.7-pag.15
7.1.4 BA BB BF Size 325 - 330 - 390: Spare parts list	Chap.7-pag.16
7.1.4.1 Pump exploded view drawing	Chap.7-pag.16
7.1.4.2 Spare parts names and codes	Chap.7-pag.17
7.1.4.3 Seals section drawings and spare parts	Chap.7-pag.21
7.1.5 BA BB Size 430 - 440: Spare parts list	Chap.7-pag.22
7.1.5.1 Pump exploded view drawing	Chap.7-pag.22
7.1.5.2 Spare parts names and codes	Chap.7-pag.23
7.1.5.3 Seals section drawings and spare parts	Chap.7-pag.25
7.1.6 BA BB Size 470 - 490: Spare parts list	Chap.7-pag.26
7.1.6.1 Pump exploded view drawing	Chap.7-pag.26
7.1.6.2 Spare parts names and codes	Chap.7-pag.27
7.1.6.3 Seals section drawings and spare parts	Chap.7-pag.29
7.2 Name and codes of pumping bodies	Chap.7-pag.30
7.3 Codes of the springs used in the mechanical safety valve	Chap.7-pag.30
7.4 Codes of the springs used in the external bridge mechanical safety valve	Chap.7-pag.31
7.5 Recommended spare parts	Chap.7-pag.31
7.6 How to order spare parts	Chap.7-pag.31
CHAPTER 8: ASSISTANCE	Chap.8-pag.1
CHAPTER 9: WARRANTY	Chap.9-pag.1





INTENDED USE

The BA BB BF Series Lobe Positive Displacement Pump Group, manufactured and marketed by O.M.A.C. s.r.l., which in this documentation will be indicated with the abbreviation LPDPG, has been designed and made to be assembled in industrial plants owned by third parties, to transfer volumes of fluids, compatible with the materials used during the construction of this machine: section 1.4.1 lists the recommended operational features of the LPDP, depending on the processed fluid.

The LPDPG requires compliance with all technical indications in this operation and maintenance manual, which in this documentation will be indicated with the abbreviation OMM, for its proper installation.

In general, the processed fluids must meet the following specifications:

Fluid properties and range of use:

- 1) TEMPERATURE: from **-35°C to +180°C**
- 2) VISCOSITY: Maximum **200'000cPs** with forced feeding
- 3) HARD PARTICLE SIZE: Maximum **80% of clearance between rotors** (see sect.1.3.4)

The LPDPG has been designed and made for two types of use:

- △ alimentary use;
- △ chemical use.



WARNING

The LPDPG, for alimentary use, has been made to ensure a hygienic standard equal to **LEVEL 3**, on the basis of **UNI EN 13951**.

The LPDPG for alimentary use and for chemical use has been designed to transfer volumes of fluids without altering the organoleptic properties nor the physical properties.



WARNING

The LPDP is **E.H.E.D.G.** certified, with **Certificate nr. 13/2008** of **TUM Technische Universität München** of Freising, Weihenstephan - Germany



WARNING

During its normal use, the LPDPG for alimentary use and chemical use does not alter the organoleptic characteristics or the physical characteristics of the processed fluid.

Every LPDPG comes with a technical sheet indicating the operational features in relation to the processed fluid that must be handled (name of the fluid, viscosity range, capacity range, speed range, temperature range), as declared at the time of purchase by the Customer.

Section 1.3 shows a facsimile of the LPDPG technical sheet.

Every modification to what is indicated in the specific technical sheet or variation of the machine operating parameters must be authorised in writing by O.M.A.C. s.r.l.; the absence of such authorisation is deemed "improper use" and will void any warranty or liability under way between Manufacturer and Customer.



DANGER

Any use of the LPDPG in conditions other than those indicated in "Fluid properties and range of use" and in conditions other than those indicated in the machine technical sheet is forbidden, without explicit written authorisation, issued by O.M.A.C. s.r.l.

The LPDPG for alimentary use and for chemical use has NOT been designed nor built to handle pharmaceutical, explosive, etc. fluids, and in general fluids that do not comply with the indications of the specific technical sheet.

In addition, the LPDPG for alimentary use and chemical use has NOT been designed nor built to handle what is indicated in Regulation (EC) No. 1005/2009 of the European Parliament and the Council of 16 September, 2009, on substances that deplete the ozone layer.



ATTENTION

It is forbidden to use the LPDPG for alimentary use and chemical use to transfer the substances listed in Annex I of Regulation No. 1005/2009.

The pumping part of the LPDP is made up of the pump body, in which two rotors are housed (sect. 1.3.5 lists the types of rotors used), which rotate synchronised in the opposite direction to each other.

The rotorcase receives the process fluid from the suction inlet, originating from the plant of the Customer. During the operation of the LPDP, the cavities between the lobes of the rotors are filled with fluid and the counter-rotation of the rotors transfers the fluid to the delivery outlet of the pump body, channelling it in the plant where the LPDPG is installed.





(Declaration of conformity to be attached)

EC DECLARATION OF CONFORMITY

EC Declaration of conformity (Machinery Directive 2006/42/EC)

We, O.M.A.C. s.r.l., with registered office in Via Falcone n.8 - 42048 Rubiera (RE) – Italy, Tel. 0522/629371 - Fax. 0522/628980
E-mail: info@omacpompe.com Website: www.omacpompe.com

hereby declare under our exclusive responsibility that:

Mrs Paola Zavaroni, Via Falcone, 8 - 42048 Rubiera (RE) Italy, is authorised to establish and keep the technical documentation relative to the machine called

“MOTORIZED BA BB BF SERIES LOBE POSITIVE DISPLACEMENT PUMP GROUP”
or “MOTORIZED BA BB BF SERIES LOBE POSITIVE DISPLACEMENT PUMP GROUP WITH ELECTRIC PANEL”
or “BA BB BF SERIES LOBE POSITIVE DISPLACEMENT PUMP GROUP complete with “TRANSMISSION DEVICE”

Model: _____ Serial No: _____ Specifications: _____

Date of issue: _____

designed and built for pumping, in a third party plant, a medium (alimentary fluid / chemical fluid) to which this declaration refers to.

The machine is compliant with the safety requirements provided by Directive 2006/42/EC

with Regulation EC No.1935/2004 

and with Directives: 2006/95/EC – 2004/108/EC – 94/9/EC
and in accordance with the provisions of the following harmonised standards:

*** REFERENCE STANDARDS***

This machine is equipped with:

Gear Unit/Speed Controller/Gear motor: _____ Supplier: _____ Specifications: _____
Electric motor/Hydraulic motor: _____ Supplier: _____ Specifications: _____
Flexible transmission coupling: _____ Supplier: _____

NOTE: any modifications to the machine, to which this declaration refers to, to the processing fluid and conditions of use of the process fluid, specified in the relative technical sheet, will make this declaration null and void. O.M.A.C. s.r.l. does not assume any liability arising from the incompatibility between the process fluid and materials which make up the machine, subject of this declaration, if the customer does not specify the particulars of the process fluid and its physical characteristics.

RUBIERA (RE)

The Legal Representative

Date _____

Signature _____



HOW TO CONSULT AND KEEP THIS DOCUMENTATION

This OMM is a document written by O.M.A.C. s.r.l. and is relative to the installation, safe use and management (maintenance) of the LPDPG, in this sense, this documentation, complete with the use and maintenance manuals supplied by the manufacturers of the single components, is an integral part of the LPDPG.

The purpose of all the documentation mentioned above is to put the users of the LPDPG in the conditions to operate safely, thus putting in place clear rules of use; this documentation must be carefully read and understood by the users.

Please note that the specifications carried on all the use and maintenance manuals, with reference to this machine, are designed to ensure safety and health of the users and therefore they must carefully read, understand and apply the indications/procedures.

The compliance with these indications enables the safe use of the machine, as well as the implementation of appropriate interventions.

As indicated above, the declaration of conformity and all use and maintenance technical manuals concerning the LPDPG will accompany it in the event it is sold to other users.

This documentation must be kept with care until the final demolition of the same LPDPG and must be made available to the personnel appointed to operate.

It is good practice not to damage the manual and keep it properly, do not tear pages, dirty them or get them greasy, never expose them to sources of heat and always maintain the proper layout. This documentation and relative annexes must also be made available to the personnel authorised to operate on the LPDPG, in such a way that it can be consulted easily, to clear any doubts about its safe operation and/or about the execution of use and maintenance procedures.

What is contained in the technical manuals reflects the state of the art at the time of construction of the machine in question. The technical manuals cannot be considered inadequate, as a result of technological improvements of the LPDPG.

The technical documentation and relative annexes are completely confidential: reserves all rights related to this use and maintenance manual and with the object presented therein. The receiving party recognises these rights to O.M.A.C. s.r.l., in the person of its Legal Representative, Mrs Paola ZAVARONI, and undertakes, in the absence of an explicit written consent, not to make it accessible to others, either in whole or in part and, not to use it outside the purpose for which it was created. Violators will be prosecuted according to law.

SYMBOLS USED

Important information, regarding the technical reliability and safe use, are highlighted in this manual in the following way (these symbols always precede the text they refer to):



DANGER

The DANGER symbol draws attention to a procedure, practice or similar measure which, if not performed correctly, can result in injury. Do not proceed beyond a DANGER symbol until you have fully understood and satisfied the conditions specified.



WARNING

The WARNING symbol draws attention to an operating procedure, practice or other similar measure that is potentially dangerous, which may involve risk of serious injury, if the instructions are not followed scrupulously.



ATTENTION

The ATTENTION symbol draws attention to an operating procedure, practice or other similar measure, which if not correctly performed or observed, can damage or completely destroy the product. Do not proceed beyond an ATTENTION symbol until you have fully understood and satisfied the conditions specified.



NOTE

Refers to technical aspects for which the user of the equipment must pay particular attention.

KEEPING THE MANUAL

The technical manuals relating to the LPDPG is part of the same unit; therefore all the above mentioned technical documentation must accompany this machine even if it is sold.



WARNING

For the proper management of safety during use and maintenance of the LPDPG, all the technical documentation must accompany it even if it is sold.



DANGER

The technical manuals contain the information / procedures concerning the use and management of safe maintenance of the LPDPG, it must be kept in the vicinity of the place in which the machine operates, to which this documentation refers, in a place easily accessible by the operator responsible for its operation. The operator responsible for its operation and the maintenance engineer must be able to find and consult this documentation at all times.



DANGER

All the technical documentation that refers to the LPDPG must be kept in an easily accessible place so that it can be consulted quickly. In addition, the personnel responsible for its use and maintenance must be informed where this documentation is kept.

LABELS APPLIED

Throughout the LPDPG there are nameplates of the various components of the same unit. The nameplate applied on the left side of the LPDP (left side of the pump looking at the rotors) carries the LPDPG serial number (the serial number starts with the letter "L" and is followed by six numbers), to which the item code of the LPDPG is uniquely associated to. The coding rule of the LPDPG item code is explained in section 1.2.2.

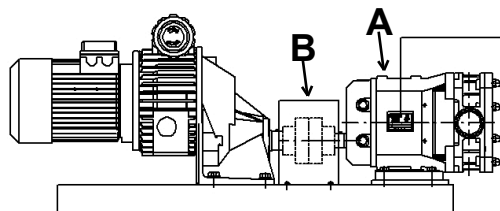

OMAC	
O.M.A.C. s.r.l. - Rubiera (RE) ITALY Tel. 0522-629371 - Fax 0522-628980	
ITEM _____	
Matr. _____	Anno _____
Mod. _____	
○ Lubrificare con olio ISO VG 68 ○	

On the surfaces of the various components of the LPDPG, there are plates with the prohibition to operate the LPDP dry (plate A), placed on the bearings box of the LPDP, and the plate warns the operator of the presence of mobile parts under the butt strap (plate B). In the event of LPDPG is predisposed for pumping fluids at temperatures above 50°C, there is a signal placed on the same pump that warns the operators of the presence of high temperature surfaces, as shown in figure C:

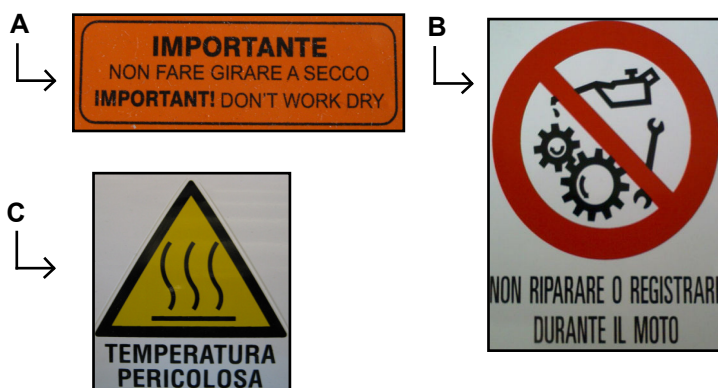

NOTE

Please note that the markings / labels present along the LPDPG cannot be removed or altered for any reason.



WARNING

It is forbidden to use any O.M.A.C. item when it is without the nameplate. Should the item be without its nameplate it is compulsory for the customer to contact the O.M.A.C. Technical Office that will see to identify the item and re-issue the nameplate.

TERMS AND DEFINITIONS

OMM: Operation and Maintenance Manual.

LPDPG: BA or BB or BF Series Lobe Positive Displacement Pump Group (control unit, gear motor, speed controller, hydraulic motor, electric panel, support base, support base on trolley, etc. + mechanical transmission device (flexible transmission coupling) + LPDP.

LPDP: BA or BB or BF Series Lobe Positive Displacement Pump Unit.

DANGEROUS AREAS: any area inside and/or in proximity of a machine in which the presence of an exposed person constitutes a risk for the safety and health of this person.

EXPOSED PERSON: any person who finds himself entirely or in part in a dangerous area.

MACHINE: together of parts as defined by Article 2 of Directive 2006/42/EC of the European Parliament and the Council of 17 May, 2006

MANUFACTURER: O.M.A.C. s.r.l

CUSTOMER: Physical or legal person on whose behalf the machine is built, upon prior written acceptance of an order confirmation.

CHAPTER 1: MACHINE AND PUMPED FLUID SPECIFICATIONS

1.1 Envisioned duration

Given the quality level of the materials and construction technologies used, if you strictly follow the instructions in this OMM (paying particular attention to chapters 3, 4 and 5, relating, respectively, to the installation, use and maintenance of the LPDPG), the expected duration of such subject matter is estimated to be 12 months from date of installation.

Please note that, during its expected life-span, the LPDPG must not be assembled and/or disassembled by unauthorised personnel and furthermore the instructions contained in this OMM must be followed scrupulously.

1.2 Technical description of the machine

Below there is a brief description of the LPDPG, as well as a functional illustration of the LPDPG, in order to more easily identify the main construction details, mentioned in the description of use and maintenance of this document.

The LPDPG is made up of 3 macro-components:

- 1) control unit (gear motor, speed controller, hydraulic motor, electric panel, etc.);
- 2) mechanical transmission device (flexible transmission coupling);
- 3) LPDP;

The LPDP, identified with number 3) is made up as follows:

- | | |
|---------------------|---------------------------|
| A = ROTORCASE COVER | C = ROTOR |
| B = LOCK NUT | E = BALANCING RING |
| D = SEAL | F = BEARING RETAINER RING |
| G = FRONT BEARING | H = REAR BEARING |
| K = OIL VENT CAP | L = REAR COVER |
| M = DRIVE SHAFT | N = FIXED GEAR |
| O = OIL LEVEL CAP | P = ADJUSTABLE GEAR |
| R = DRIVEN SHAFT | S = BEARING HOUSING |
| T = FOOT | U = ROTORCASE |

1.2.1 Operation principle of the LPDP

The LPDPG, whose functional element is the LPDP, is equipped with a control unit that, depending on the version, can be fitted with a gear motor, an electric motor, a pneumatic motor or a hydraulic motor, with or without electric panel. The capacity adjustment is achieved by increasing or decreasing the number of revolutions of the LPDPG, intervening directly on the revolutions output of the motor or acting on the actuators on the control panel (inverter), if fitted.

The LPDP is reversible: full performance can be achieved in both rotation directions of the pump rotors (section 1.3.5 of chapter 1 lists the types of rotors used).

The pumping action of the LPDP is achieved thanks to the counter-rotation of two rotors (letter "C" indicated in the figure in section 1.2, indicating one of the two rotors), housed inside the pumping chamber (letter "U" indicated in the figure in section 1.2 or see figure below). The rotors are assembled on rotating shafts supported by bearings (letters "G" and "H" shown in the figure in section 1.2), which are housed in the external gearbox (letter "S" shown in the figure in section 1.2). Via a couple of sprocket wheels (letters "N" and "P" indicated in the figure in section 1.2) one transfers motion from a drive shaft (letter "M" indicated in the figure in section 1.2) to a driven shaft (letter "R" indicated in the figure in section 1.2). The synchronism of the rotors is such that they rotate without coming into contact with each other: in these conditions "the rotors are in phase".

When the lobes of the rotors move away from each other, the volume between them increases, creating a decrease in pressure near the suction outlet: this enables a certain volume of fluid to enter (value of fluid transported identified in the table in section 1.3.1, in the "theoretical capacity" column, depending on the pump model size) into the pumping body. The fluid is transported along the internal of the pumping chamber, from the suction inlet to the delivery outlet of the pump body.

When the volume of fluid, trapped between the lobes and the external perimeter of the pumping chamber, reaches in proximity of the delivery outlet, the counter-rotation of the two rotors creates a sudden decrease of available volume and a consequent increase in pressure that pushes the fluid out of the pump body, by channelling it into the plant where the LPDPG is installed.

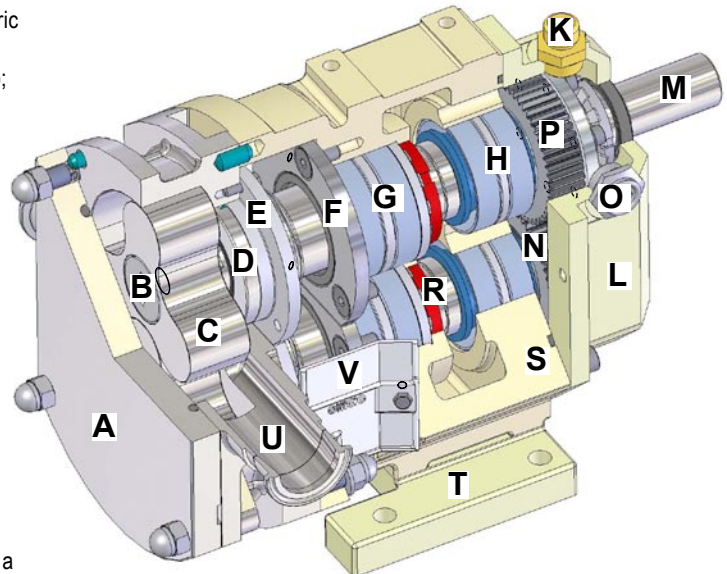
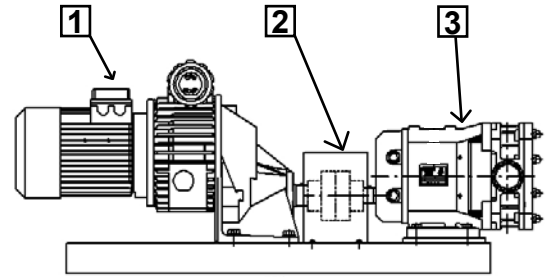

FRONTAL VIEW OF THE PUMP CHAMBER

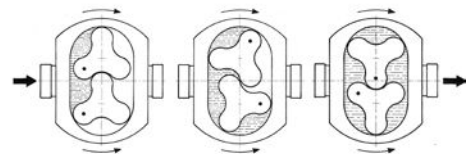

REAR VIEW OF THE PUMP SHAFT

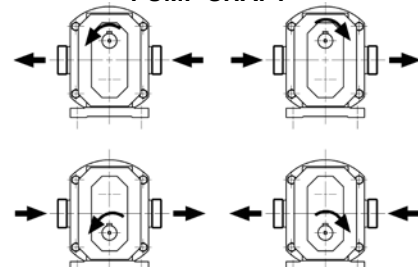

WARNING

If the control unit does not comply with the rotation direction indicated in the figure, the mechanical functionality of the LPDPG is not compromised, but will not supply any delivery capacity. Failure to comply with the proper connection to the unit (suction inlet connected to the suction piping and delivery outlet connected to the unit delivery pipe) will cause improper installation of the LPDPG by the customer.

1.2.2 BA BB BF Series lobe positive displacement pump coding

DIFFERENCES BETWEEN BA BB BF SERIES:

BB SERIES: RESTAYLING STANDARD B SERIES – BEARING BOX IN CAST IRON AS STANDARD

BA SERIES: BB + 3-A CERTIFICATION (WELDED CONNECTIONS) – BEARING BOX IN CAST IRON AS STANDARD OR IN AISI 304 AS OPTIONAL

BF SERIES: BA/BB SERIES (INTEGRAL CONNECTIONS+ROTORCASE CASTING) – BEARING BOX IN STAINLESS STEEL (CAST IRON AS OPTIONAL)

AVAILABLE SIZES:

BA AND BB SERIES: FROM SIZE 100 TO SIZE 490

BF SERIES: FROM 100 TO SIZE 330

The LPDPG is identified by an item code, represented by a string of 18 alphanumeric characters that starts with "K" (the item code is detectable on the first line of the technical sheet of which there is an example in section 1.3) divided into the following structure:

K	1	1	2	3	4	5	6	7	7	7	8	8	9	V	V	V	V
---	---	---	---	---	---	---	---	---	---	---	---	---	---	---	---	---	---

Fields 1-1: pump series = "BA" - "BB" - "BF"

Field 2: pump size

A = 100; **B** = 105; **C** = 110; **D** = 115; **E** = 215; **F** = 220; **G** = 325; **H** = 330; **L** = 390; **M** = 430; **N** = 440; **P** = 470; **Q** = 490;

Field 3: seal type

3 = Single Mechanical Stainless Steel/Carbon;

5 = Single Mechanical Tungsten carbide/Tungsten carbide;

7 = Single Mechanical Ceramic/Rulon;

9 = Single Mechanical Tungsten carbide/Silicon carbide;

4 = Single Mechanical Tungsten carbide/Carbon;

6 = Single Mechanical Ceramic/Carbon;

8 = Single Mechanical Silicon carbide/Silicon carbide;

A = Single Mechanical Silicon carbide/Carbon;

Field 4: suction-discharge connections type

0 = GAS-BSP;

3 = SMS;

6 = TRI-CLAMP;

A = Aseptic O.M.A.C.;

D = DIN 11864/3a;

G = DIN 11864/3b;

K = flanged IDF;

N = DIN 11851 (male);

R = ISO KF CLAMP;

1 = flanged PN16 UNI EN 1092-1 – DIN2576;

4 = RJT (BS);

7 = GAS;

B = DIN 11864/1a;

E = DIN 11864/1b;

H = flanged PN40 UNI 6084-67/DIN 2501;

L = smooth for welding;

P = MACON;

2 = DIN 11851;

5 = IDF-ISS;

8 = wine fitting;

C = DIN 11864/2a;

F = DIN 11864/2b;

J = flanged ASME 150lb;

M = DS 722;

Q = flanged 5044/DIN 11850;

Field 5: tipo di rotori:

0 = Trilobe

Stainless Steel

ST;

B = Dual Wing

Stainless Steel

ST

1 = Trilobe/Gear

Stainless Steel

SM;

C = Dual Wing

Stainless Steel

SM

2 = Bilobe

Stainless Steel

ST;

E = Quadrilobe

Stainless Steel

SM

3 = Bilobe

Stainless Steel

SM;

F = Trilobe

Stainless Steel

SM;

4 = Trilobe

Stainless Steel

ST;

L = Trilobe/Gear

CY5SnBIM (antiseizure)

SM;

5 = Dual Wing

CY5SnBIM(antiseizure)

ST;

M = Dual Wing

CY5SnBIM (antiseizure)

SM;

6 = Bilobe

Stainless Steel

ST;

N = Trilobe

CY5SnBIM (antiseizure)

PR;

7 = Trilobe/Gear

CY5SnBIM (antiseizure)

ST;

P = Dual Wing

CY5SnBIM (antiseizure)

PR;

8 = Gear	Stainless Steel	ST;	P = Dual Wing	CY5SnBIM (antiseizure)	PR;
9 = Quadrilobe	Stainless Steel	ST;	Q = Gear	CY5SnBIM (antiseizure)	ST ultrareduced;
A = Bilobo	CY5SnBIM(antiseizure)	ST;	R = Gear	CY5SnBIM (antiseizure)	ST reduced;

(ST= standard rotor clearance; SM = increased rotor clearance; PR = exact rotor clearance)

Field 6: cover type

0 = standard;	4 = with wetted o-ring;	8 = with drainage;
1 = with mechanical safety valve;	5 = for built in locking nut;	A = aseptic;
2 = heated;	6 = for ultrareduced pump version;	B = with mechanical safety valve and drainage;
3 = with pneumatic safety valve;	7 = for built in locking nut and heated;	

Fields 7-7-7: pump single optionals

A = aseptic pump;	L = rectangular suction connection;	X = Atex pump certified;
B = pump o-ring in N.B.R. (Buna);	M = pump in monel;	Y = pump in hastelloy;
C = flushing for single mechanical seal in F.K.M. (°Viton);	N = niploy treatment;	Z = pump in hastelloy-titanium;
D = duplex shafts;	P = pump o-ring in teflon;	1 = cheniflon treatment;
E = PACD treatment;	R = heated pumping case;	2 = bearing housing S.S.Aisi 304;
F = pump o-ring in kaffon 72B™;	S = poliuretanic lip seal;	3 = pump o-rings 3-A certified;
G = inner polishing surface Ra<0.8μ;	T = hydraulic flange pump;	6 = nichel-plated cast iron bearing housing;
H = high pressure pump;	U = pump o-ring in E.P.D.M.;	7 = with feet for vertical connections disposition;
J = pump in titanium;	V = pump o-ring in F.K.M. °VITON;	9 = internal mechanical seals;
K = kolsterizing treatment ;	W = pump o-ring in Kalrez Spectrum6375;	0 = no options;

Fields 8-8: pump group optionals

GG = inner polishing surface Ra<0.6μ;
11 = connections modified ø suction/discharge to DN20 (3/4");
12 = connections modified ø suction/discharge to DN25 (1");
13 = connections modified ø suction/discharge to DN32 (1" 1/4);
14 = connections modified ø suction/discharge to DN40 (DN38) (1"1/2);
15 = connections modified ø suction/discharge to DN50 (DN51) (2");
16 = connections modified ø suction/discharge to DN65 (DN63) (2"1/2);
17 = connections modified ø suction/discharge to DN80 (DN73) (3");
18 = connections modified ø suction/discharge to DN100 (DN101) (4");
19 = connections modified ø suction/discharge to DN125 (5");
21 = connections modified ø suction/discharge to DN150 (6");
22 = connections modified ø suction/discharge to DN200 (8");
23 = suction connections ø DN125/discharge connections ø DN100;
24 = flanged suction connection PN16 UNI2278/flanged discharge connection DIN11851;
28 = bearing housing S.S.Aisi 304 elettropolished;
29 = External polishing of bearing housing and pumping case

Field 9: seal model

8 = Roten 7KFO seal;

Fields V-V-V-V: progressive versioning number

Digital counter that versions the item code according to the type of accessories and type of LDPU and according to the type of associated control unit.

1.3 Technical features

The technical data of the LPDPG is listed in the "technical sheet", of which there is an example below. The technical sheet is delivered to the Customer together with the LPDPG, in original and edited without the possibility of manual corrections.



ATTENTION

The technical sheet must not have any manual corrections or deletions.

The technical sheet lists the item code, which identifies the LPDPG, the serial number (detectable on the riveted nameplate on the bearings box of the LPDP), its functional features (processed fluid and its properties, pump speed, volumetric capacity, differential pressure,..) and the features of the LPDPG components.

The technical sheet below lists the technical data of the control unit (motorisation, gear motor, speed controller,..), of the flexible mechanical transmission coupling, that connects the LPDP to the motorisation, and the type of support on which the LPDP is fitted.

The exploded view below highlights the position numbers of some components of the LPDP which will be discussed later in this chapter.

O.M.A.C. S.r.l.		DATA SHEET			Mod. 13 04 del 31/07/2008			
Via G. Falcone 8 42048 RUBIERA (RE) ITALY Tel/Fn. 0039-0522-62.93.71 / 62.99.23 Fax 0039-0522-62.89.80 http://www.omacpompe.com E-mail: info@omacpompe.com		Codice Cliente 000000000	Tipo A	Numero 0000000	Data _/_/			
Nostro Riferimento		Vostro Riferimento						
Innestatore Ordine		Destinatario Merce		Destinatario Ordine				
Riga	Descrizione	U.M.	Quantità	Q.tà Totale	Sconti	Importo	IVA	Consegna
	KBC000000000000000000000000 PUMP	NR	1 DI	1,00				
Serial number L000000								
PRODUCT INFO		MEDIA DESCRIPTION VISCOSITY* TEMPERATURE						
PUMP PERFORMANCES		FLOW-RATE PRESSION PUMP SPEED TORQUE ABSORBED POWER						
TECHNICAL FEATURES		MODEL CERTIFICATION ROTOS SEAL TYPE SEAL GASKETS SUCTION - DISCHARGE CONNECTIONS Ø SUCTION - Ø DISCHARGE CONNECTIONS DISPOSITION PUMP COVER PUMP GASKETS SHAFT POSITION BEARING HOUSING OIL NAME PLATE						
SUPPORT FEATURES		TYPE SIZE						
JOINT FEATURES		TYPE CARTER HOLE (PUMP) HOLE (MOTORIZATION)						
PUMP ANCILLARIES								
DOCUMENTS								

Informativa d.lgs 30.6.2003 n. 196 TU Privacy I suoi dati personali saranno trattati, nel rispetto delle idonee misure di sicurezza, per invio di comunicazioni commerciali, potrà esercitare i diritti previsti dalla legge e nelle modalità ivi completate. Titolare del trattamento dati è O.M.A.C. S.r.l., sede legale: 42048 Rubiera in Via G.Falcone, 8. Per comunicazioni info@omacpompe.com. Per ulteriori informazioni www.omacpompe.com

The exploded view below highlights the position numbers of some components which will be discussed later in this chapter.

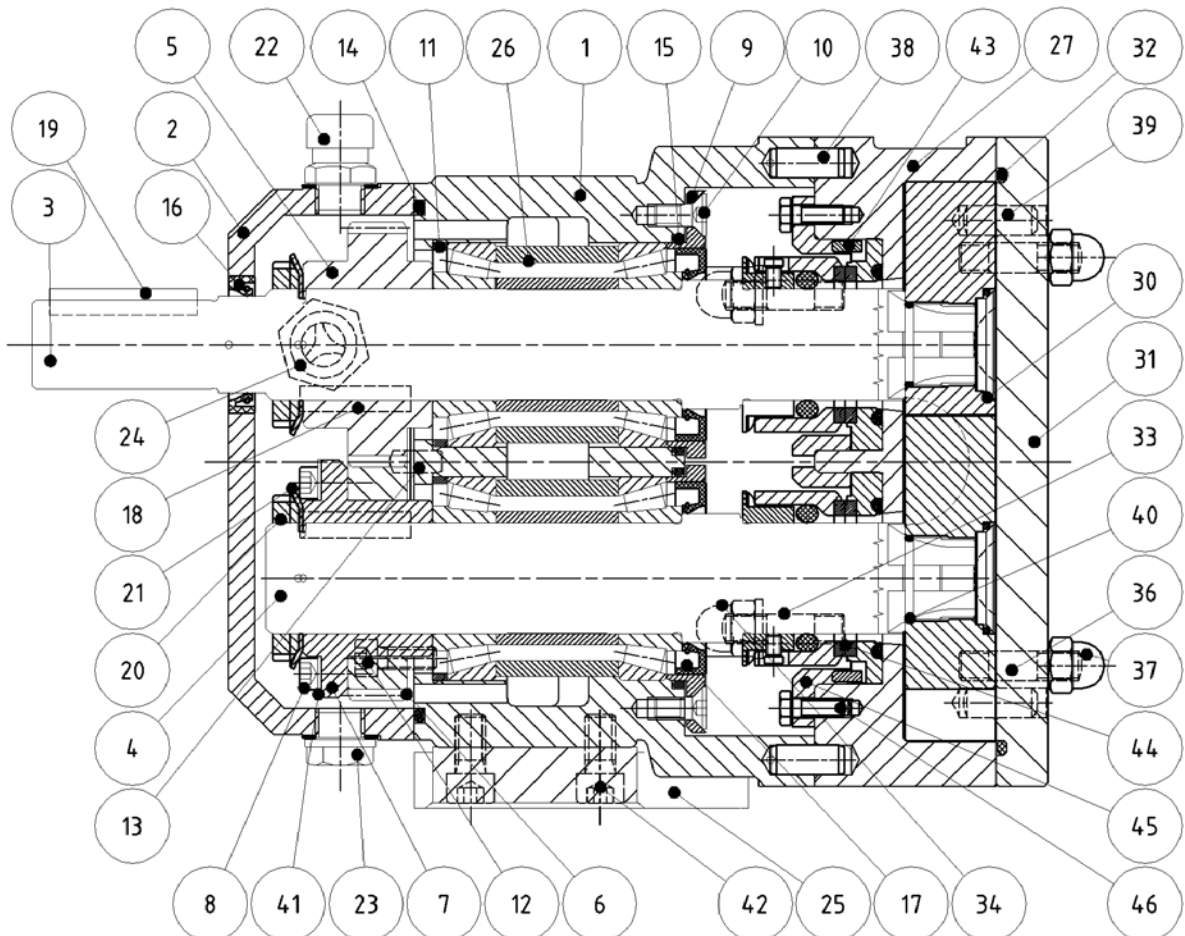

1.3.1 Technical features of the LPDPG

The table below shows the nominal features of the various dimensions of the LPDP, inserted in the LPDPG. The data that make up the table refer to the pump model, the capacity that each pump model (BA BB BF100, BA BB BF105, BA BB BF110...) elaborates every 100 revolutions, the maximum operation speed of each pump size, the differential operating pressure, expressed in bar, and the standard dimensions of the opening couplings, expressed in millimetres and inches.

PUMP MODEL	THEORETIC CAPACITY	MAXIMUM SPEED	MAXIMUM POWER	MAXIMUM OPERATING PRESURE (bar)					STANDARD CONNECTION	
				rotor clearances ST (standard) with shafts		rotor clearances SM (increased) with shafts		High pressure Duplex + Acteon	DN	Inches
				S.S. AISI 316 L	DUPLEX	S.S. AISI 316 L	DUPLEX			
100	3	1400	1.5	7	10	-	-	-	25	1"
105	7	1000	4	10	13	15	18	-	40	1" 1/2
110	12	1000	4	10	13	15	18	20	40	1" 1/2
115	18	1000	5.5	7	10	12	15	-	40	1" 1/2
215	23	950	7.5	10	13	15	18	20	40	1" 1/2
220	34	950	7.5	7	10	12	15	-	50	2"
325	55	720	18.5	10	13	15	18	20	65	2" 1/2
330	70	720	18.5	7	10	12	15	-	80	3"
390	90	720	18.5	5	7	10	12	-	80	3"
430	116	600	30	10	13	15	18	20	80	3"
440	155	600	30	7	10	12	15	-	100	4"
470	240	500	45	10	13	15	18	20	100	4"
490	330	500	45	7	10	12	15	-	100	4"

1.3.2 Variation of maximum operating pressure according to temperature

The table below lists the maximum differential pressure values, processed by the LPDP, inserted in the LPDPG, according to the size of the pump (from BA BB BF100 to BA BB 490), according to the temperature of the processed fluid (from 0-70°C, 90°C, 110°C,..) and according to the type of rotors fitted: with clearances between rotor and ST standard pumping chamber, SM increased clearances or clearances for HP high pressures.

The values of these clearances between rotors and pumping chamber are shown in the section 1.3.4.

TEMPERATURE °C	ROTOR TYPE	BA BB BF SERIES MODEL PUMP												
		100	105	110	115	215	220	325	330	390	430	440	470	490
0°C a 70°C	ST	7	10	10	7	10	7	10	7	5	10	7	10	7
	SM	-	15	15	12	15	12	15	12	10	15	12	15	12
	HP	-	-	20	-	20	-	20	-	-	20	-	20	-
90°C	ST	5.2	8.8	8.9	6.5	9	6.5	9.1	6.5	4.5	9.1	6.4	9.1	6.3
	SM	-	15	15	12	15	12	15	12	10	15	12	15	12
	HP	-	-	18.8	-	18.9	-	19	-	-	19	-	19	-
110°C	ST	4	7.6	7.8	5.7	8	5.9	8.2	6	-	8.4	5.8	8.4	5.9
	SM	-	15	15	12	15	21	15	12	-	15	12	15	12
	HP	-	-	17.6	-	17.7	-	18	-	-	18	-	18	-
120°C	ST	3.4	7	7.3	5.5	7.5	5.6	7.8	5.7	-	7.9	5.5	7.8	5.4
	SM	-	14	14.6	11.7	14.5	11.7	14.5	11.7	-	14.6	11.7	14.6	11.6
	HP	-	-	17.1	-	17.2	-	17.6	-	-	17.5	-	17.5	-
140°C	ST	2.2	6	6.3	5.1	6.5	5	7	5.2	-	7.2	4.9	7.2	4.9
	SM	-	13	13.6	11.3	13.6	11.1	13.8	11.2	-	13.7	11.1	13.7	11.1
	HP	-	-	16.1	-	16.3	-	16.8	-	-	16.6	-	16.6	-
160°C	ST	-	-	5.3	5	5.5	4.4	6.1	4.6	-	6.4	4.3	6.4	4.2
	SM	-	-	12.7	10.8	12.7	10.5	12.9	10.7	-	12.9	10.4	12.7	10.4
	HP	-	-	15.1	-	15.3	-	15.8	-	-	15.8	-	15.6	-
180°C	ST	-	-	4.3	4.2	4.5	3.9	5.2	4.1	-	5.5	3.6	5.4	3.6
	SM	-	-	12.1	9.9	11.8	10.5	12.1	10.1	-	12	9.7	12	9.7
	HP	-	-	14.1	-	14.3	-	14.9	-	-	14.9	-	14.6	-

1.3.3 Motorization and transmission coupling technical features

The mechanical features of the flexible transmission coupling and the performance features of the control unit (electrical, pneumatic, hydraulic), according to the type of operation chosen by the customer, are shown in the respective use and maintenance manuals; documents that are supplied with the LPDPG.

1.3.4 Rotors clearances

This section lists the nominal clearances (ST standard, SM increased), that are recorded between rotors and walls of the pumping chamber according to the material (AISI 316 L, anti-seizure alloy CY5SnBIM). The figure, on the next page, represents a rotor section, fitted in the pumping chamber, with indication of clearances, identified by letters A,B,C,D. The table below shows the entirety of these clearances.

The "S" value represents the protrusion of the shaft compared to the wall of the pumping chamber.

	ROTORS S.S. AISI 316 L				ROTORS S.S. AISI 316 L				ROTORS ANTISEIZURE				SHAFT
	ST VERSION				SM VERSION				CY5SnBIM				PROTRUSION
	A	B	C	D	A	B	C	D	A	B	C	D	S
100	0.12	0.12	0.15	0.2	0.15	0.15	0.2	0.2	0.07	0.08	0.19	0.15	0.12
105	0.12	0.14	0.15	0.25	0.17	0.19	0.2	0.3	0.05	0.05	0.13	0.15	0.12
110	0.14	0.14	0.15	0.3	0.19	0.19	0.23	0.3	0.08	0.07	0.15	0.2	0.14
115	0.14	0.14	0.18	0.3	0.19	0.19	0.22	0.3	0.07	0.08	0.2	0.2	0.14
215	0.15	0.15	0.18	0.3	0.22	0.23	0.3	0.3	0.08	0.07	0.18	0.2	0.15
220	0.15	0.17	0.23	0.3	0.25	0.25	0.32	0.3	0.08	0.07	0.2	0.2	0.15
325	0.17	0.17	0.2	0.35	0.25	0.25	0.32	0.35	0.08	0.08	0.2	0.2	0.17
330	0.17	0.19	0.23	0.35	0.27	0.28	0.32	0.35	0.09	0.08	0.23	0.2	0.17
390	0.17	0.19	0.23	0.35	0.27	0.28	0.32	0.35	0.09	0.08	0.23	0.2	0.17
430	0.18	0.18	0.22	0.35	0.27	0.27	0.32	0.35	0.09	0.08	0.23	0.2	0.18
440	0.18	0.18	0.22	0.35	0.27	0.27	0.32	0.35	0.1	0.1	0.25	0.2	0.18
470	0.2	0.2	0.27	0.35	0.32	0.32	0.35	0.35	0.09	0.09	0.25	0.2	0.2
490	0.23	0.23	0.3	0.35	0.35	0.35	0.35	0.45	0.09	0.09	0.25	0.2	0.23

Dimensions expressed in mm - Tolerances 0/+0.03

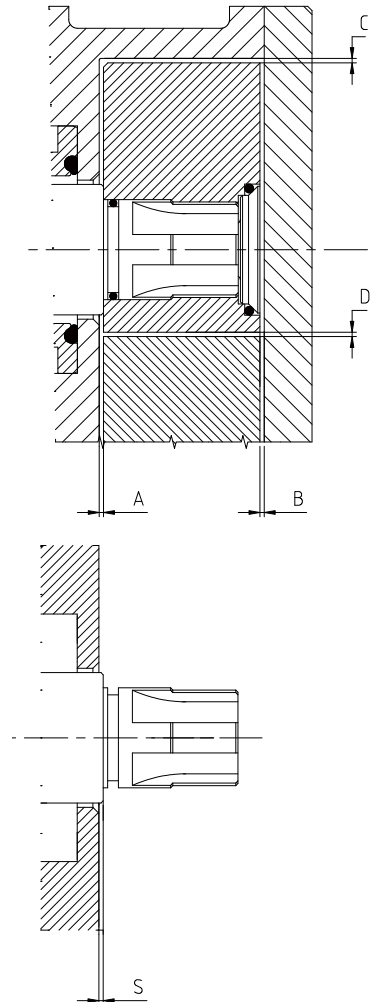

1.3.5 Rotors geometry

The table below shows the types of rotors, per type of construction material and geometric shape, available for every size of LPDP.

ROTOR TYPE	BA BB BF SERIES MODEL PUMP													
	100	105	110	115	215	220	325	330	390	430	440	470	490	
GEAR S.S. AISI 316 L	•	•												
GEAR CY5SnBIM	•	•												
DUAL-WING S.S. AISI 316 L						•								
DUAL-WING CY5SnBIM	•	•	•	•	•	•	•	•	•	•	•	•	•	
TRILOBE S.S. AISI 316 L			•	•	•	•	•	•	•	•	•	•	•	
TRILOBE CY5SnBIM			•	•	•	•	•	•		•	•			
RUBBER COATED TRILOBE (*)	•	•	•	•	•	•								
BILOBE S.S. AISI 316 L	•		•	•	•	•	•	•	•	•	•	•	•	
BILOBE CY5SnBIM	•		•	•	•	•	•	•		•	•			
RUBBER COATED BILOBE						•		•		•	•			

(*) Penta-lobe for BA BB BF100 and BA BB BF105

1.3.6 Tightening torque

This table shows the tightening torque values, to be used as reference during all assembly and disassembly operations of pump components, in one or more parts. The values mentioned in the table below relate to gear adjustment, rotor blocking, pumping body blocking, front cover blocking, bearing ring blocking and gear ring blocking.

PUMP MODEL	GEAR ADJUSTMENT (pos.8, pag.15)			ROTOR LOCKING (pos.42, pag.15)			PUMPING CASE LOCKING (pos.52, pag.15)			FRONT COVER LOCKING (pos.51, pag.15)		
	Thread d x pitch	Key type / Size [mm]	TORQUE [Nm]	Thread d x pitch	Key type / Size [mm]	TORQUE [Nm]	Thread d x pitch	Key type / Size [mm]	TORQUE [Nm]	Thread d x pitch	Key type / Size [mm]	TORQUE [Nm]
100	M4X0.7	A/7	3	M8X1	A/17	25	M6X1	A/10	10	M6X1	A/10	10
105 110 115	M5X0.8	B/4	5	M12X1	A/27	85	M8X1.25	A/13	30	M8X1.25	A/13	30
215 220	M6X1	B/5	10	M14X1.5	A/30	190	M10X1.5	A/17	50	M10X1.5	A/17	50
325 330 390	M8X1.25	B/6	20	M20X1.5	A/38	305	M12X1.75	A/19	70	M10X1.5	A/17	50
430 440	M10X1.25	B/8	50	M24X2	A/46	480	M16X2	A/24	115	M12X1.75	A/19	70
470 490	M10X1.25	B/8	50	M24X2	A/46	480	M20X2.5	A/30	180	M14X2	A/22	95

PUMP MODEL	BEARING RING NUT LOCKING (pos.21, pag.15)			GEAR RING NUT LOCKING (pos.42, pag.15)		
	Thread d x pitch	Key type / Size [mm]	TORQUE [Nm]	Thread d x pitch	Key type / Size [mm]	TORQUE [Nm]
100	-	-	-	M20X1	HN4	50
105 110 115	M30X1.5	HN6	90	M30X1.5	HN6	90
215 220	M40X1.5	HN8	105	M35X1.5	HN7	90
325 330 390	M50X1.5	HN10	115	M40X1.5	HN8	105
430 440	M70X2	HN14	220	M60X2	HN12	145
470 490	M80X2	HN16	400	M70X2	HN14	220

The "A" type spanner - re. "spanner type" column - is a polygonal spanner; the BA BB BF type spanner - ref. "spanner type" column - is hexagonal (inbus or imbus).



With regard to the tightening torque value of the elements that make up the LPDP, please refer to the use and maintenance manuals (flexible transmission coupling, motorization).

1.3.7 Mechanical seals overall dimensions

Below there are the overall dimensions of the mechanical seals fitted on the BA BB BF series lobe pump, according to the size of the pump and the position of the seal. The drawing below shows the references relative to the main dimensions of the mechanical seals, whose values, in mm, are shown in the table, according to the size of the pump.

	100	105 110 115	215 220	325 330 390	430 440	470 490
d1	20	30	35	50	65	80
d2	40	57	70	84	110	130
L1	27	38	38	43.9	49.5	53.5
L2	21	28	28	33.4	37.5	40.5
L3	6.5	10	10	10.5	12	13

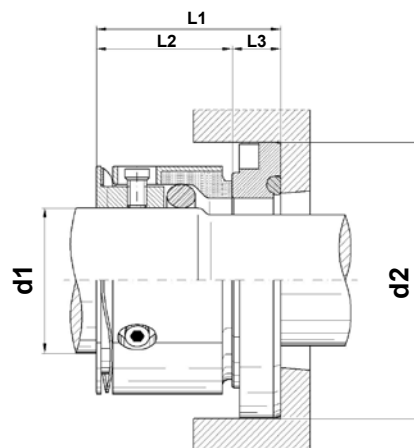

1.3.8 Weights and dimensions table of the LPDPG

The table below shows the dimensions of the LPDP, with reference to its size and according to the type of connections it is equipped with. With regard to the dimensions of the LPDP, these vary according to the type of control unit supplied, therefore they must be expressly requested to the O.M.A.C. Technical Office.

PUMP WITH CONNECTIONS IN HORIZONTAL POSITION

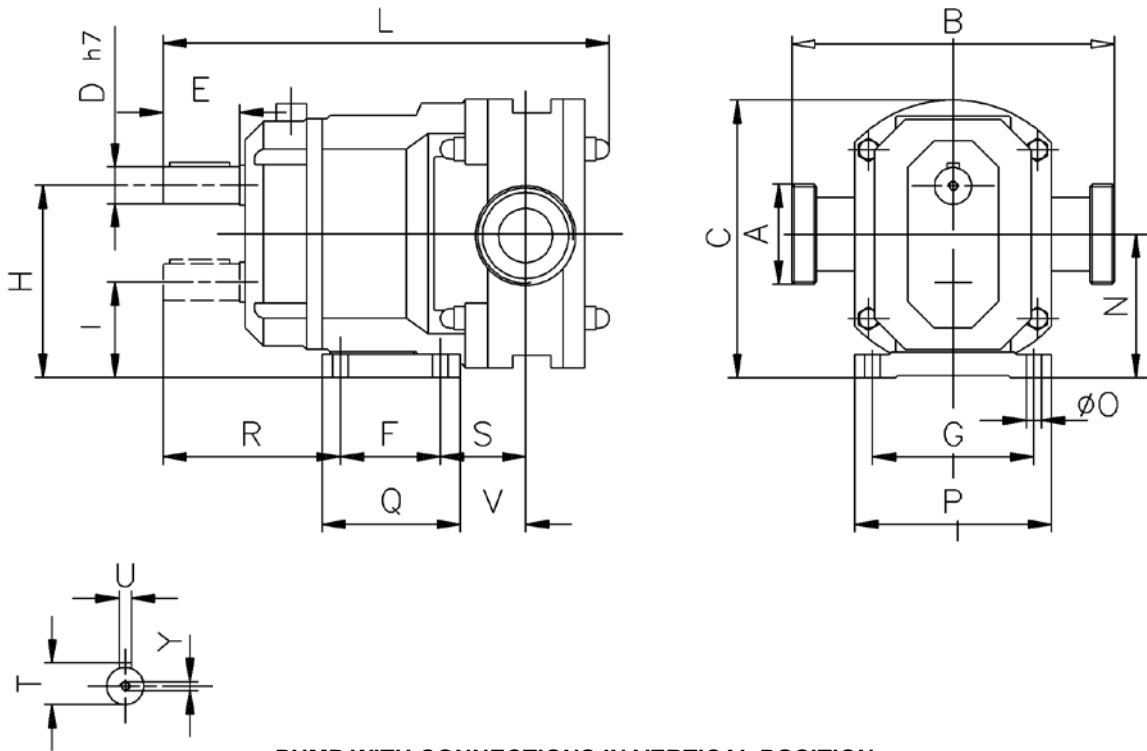

PUMP WITH CONNECTIONS IN VERTICAL POSITION

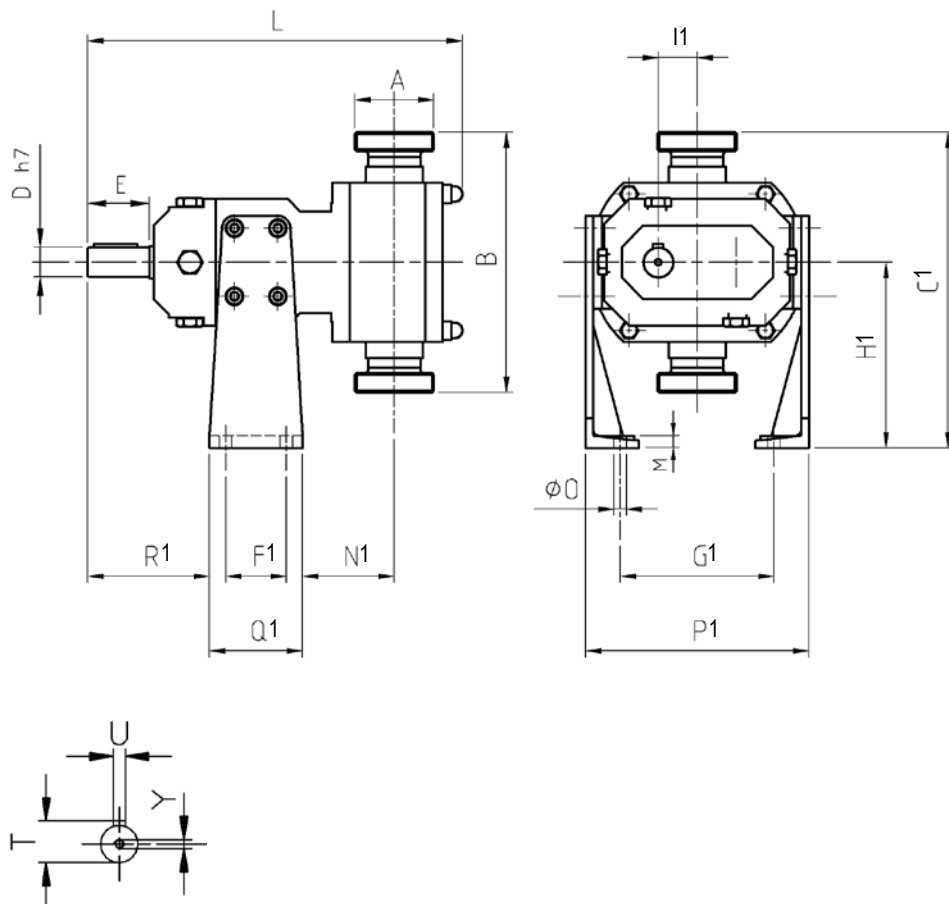

POSITION	MODEL PUMP													
	100	105	110	115	215	220	325	330	390	430	440	470	490	
C	115.5	181	181	181	235.5	235.5	270	270	270	367.5	367.5	442.5	442.5	
D	18	24	24	24	28	28	35	35	35	48	48	55	55	
E	43.5	50	50	50	55	55	65	65	65	85	85	110	110	
F	65	65	65	65	90	90	120	120	120	140	140	150	150	
F1	-	49	49	49	87	87	110	110	110	135	135	175	175	
G	105	105	105	105	125	125	140	140	140	190	190	250	250	
G1	-	124	124	124	166	166	192	192	192	270	270	320	320	
H	80	125	125	125	165	165	190	190	190	255	255	300	300	
H1	-	150	150	150	155	155	175	175	175	210	210	300	300	
I	-	62	62	62	90	90	100	100	100	130	130	160	160	
I1	-	31.5	31.5	31.5	37.5	37.5	45	45	45	62.5	62.5	70	70	
L	265	290.5	290.5	302.5	365.5	380.5	459	474	494	543.5	563.5	654	684	
N	58.6	93.5	93.5	93.5	127.5	127.5	145	145	145	192.5	192.5	230	230	
N1	-	62.5	62.5	74	81	90	107	116	136	119	126.5	118.5	148	
O	9	10	10	10	12	12	14	14	14	18	18	22	22	
P	125	128	128	128	152	152	174	174	174	235	235	300	300	
P1	-	180	180	180	240	240	272	272	272	360	360	430	430	
Q	92	90	90	90	130	130	170	170	170	195	195	255	255	
Q1	-	75	75	75	115	115	140	140	140	170	170	220	220	
R	110.5	115.5	115.5	115.5	136.5	136.5	167	167	167	206.5	206.5	255	255	
R1	110.5	98.5	98.5	98.5	108.5	108.5	134	134	134	165.5	165.5	210	210	
S	52	55.5	55.5	67	78	87	94	103	123	109	116.5	143.5	173	
T	20.5	27	27	27	31	31	38.5	38.5	38.5	52	52	60	60	
U	6	8	8	8	8	8	10	10	10	14	14	16	16	
V	49.5	42.5	42.5	54	52	61	62	71	91	76.5	84	63.5	93	
Y	-	M6	M6	M6	M8	M8	M10	M10	M10	M12	M12	M12	M12	
Kg.	10.5	20	20	21	41	43	63	65	69	130	135	225	233	
GAS BSP	A	1"	1" 1/2	1"1/2	1"1/2	1"1/2	2"	2"1/2	3"	3"	3"	4"	4"	4"
	B	160	170	170	170	208	208	236	236	236	335	335	385	385
	C1	-	235	235	235	259	259	293	293	293	377.5	377.5	492.5	492.5
FLANGED UNI 1092 ex 2278 PN16	A	DN25	DN40	DN40	DN40	DN40	DN50	DN65	DN80	DN80	DN80	DN100	DN100	DN100
	B	165	186	186	186	224	228	256	256	256	355	355	405	405
	C1	-	243	243	243	267	269	303	303	303	387.5	387.5	502.5	502.5
DIN 11851	A	DN25	DN40	DN40	DN40	DN40	DN50	DN65	DN80	DN80	DN80	DN100	DN100	DN100
	B	160	210	210	210	248	248	296	296	296	395	395	445	445
	C1	-	255	255	255	279	279	323	323	323	407.5	407.5	522.5	522.5
SMS	A	DN25	DN38	DN38	DN38	DN38	DN51	DN63	DN76	DN76	DN76	DN101	DN101	DN101
	B	150	210	210	210	248	248	296	296	296	395	395	445	445
	C1	-	255	255	255	279	279	323	323	323	407.5	407.5	522.5	522.5
IDF-ISS	A	DN25	DN38	DN38	DN38	DN38	DN51	DN63	DN76	DN76	DN76	DN101	DN101	DN101
	B	153	210	210	210	248	248	296	276	276	375	378	428	428
	C1	-	255	255	255	279	279	323	323	323	397.5	399	514	514
RJT	A	DN25	DN38	DN38	DN38	DN38	DN51	DN63	DN76	DN76	DN76	DN101	DN101	DN101
	B	157	210	210	210	248	248	290	286	286	385	389	439	439
	C1	-	255	255	255	279	279	320	318	318	402.5	404.5	519.5	519.5
TRI CLAMP	A	1"	1"1/2	1"1/2	1"1/2	1"1/2	2"	2"1/2	3"	3"	3"	4"	4"	4"
	B	160	210	210	210	248	248	293	290	290	389	392	442	442
	C1	-	255	255	255	279	279	321.5	320	320	404.5	406	521	521

For other connections please contact the Technical Department Omac

1.3.9 Dimensions of the heating/cooling rotorcase connections and of the flushing seals connections

At times the Customer may request, according to the production needs, to heat/cool the pumping chamber or to fit some flushed mechanical seals (for further information please refer to section 1.11). The dimensions of the heating / cooling fluid inlet and outlet holes of the pumping chamber and the dimensions of the flushing holes of the mechanical seals are shown in the following table and are divided per pump model.

Dimensions A, B and C are expressed in inches, dimensions D, E, F, G, L in millimetres.

POS.	DESCRIPTION	PUMP MODEL											
		100	105 110	115	215	220	325	330	390	430	440	470	490
A	Seal flushing holes	-	1/8"	1/8"	1/8"	1/8"	1/8"	1/8"	1/8"	1/8"	1/8"	1/8"	1/8"
B	Rotor case heating fluid connections size	-	1/2"	1/2"	1/2"	1/2"	1/2"	1/2"	1/2"	1/2"	1/2"	3/4"	3/4"
C	End cover heating fluid connections size	1/8"	1/2"	1/2"	1/2"	1/2"	1/2"	1/2"	1/2"	1/2"	1/2"	3/4"	3/4"
D	Distance between end cover fluid connections	56	75	75	100	100	122	122	122	150	150	180	180
E	Nut height	12	15	15	18	18	18	18	18	22	22	25	25
F	End cover heating chamber thickness	17	20	20	20	20	20	20	20	18	18	23	23
G	End cover heating chamber diameter	104	126	126	156	156	179	179	179	219	219	280	280
L	Pump length	256	295.5	307.5	367.5	382.5	461	476	476	543.5	563.5	654	684



ATTENTION

The drawing on the right shows the connection method of the seals flushing system, with indication of the flushing liquid circulation direction. Carefully read and understand the flushing operation methods described in section 5.7.4.

FLUSHING DISPOSABLE CIRCUIT

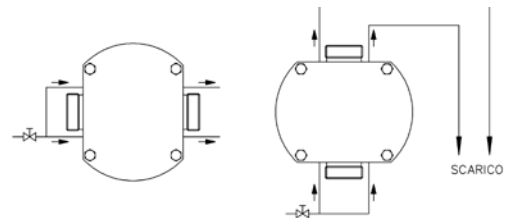

HEATING / COOLING PUMPING CASE AND FRONT COVER

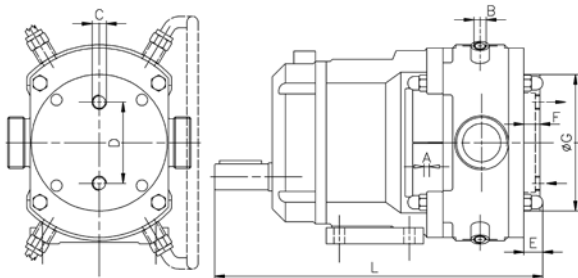

FLUSHING CIRCUIT WITH TANK

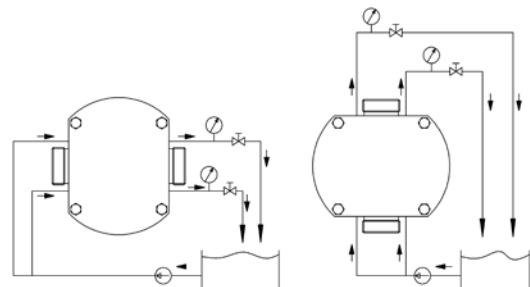

1.3.10 Suction inlet dimensions in "widened rectangular inlet" version of the LPDP

To facilitate handling of viscous fluids or fluids that contain a percentage of solids, O.M.A.C. has designed and manufactured a LPDP with a widened rectangular suction inlet (see indication in the drawing below).

PUMP MOD.	POSITION									
	A	B	C	D	E	F	G	H	L	M
115	40	22	18	90	70	42	23	19	61	120
220	55	31	24	110	92	54	32	22	72	150
330	75	37	38	146	133	65	32	33	93	176
440	75	32.5	42.5	230	180	81	40.5	40.5	115	248
490	107	67	40	230	180	107	69	38	143	256

PUMP MOD.	POSITION									
	N	O	P	Q	R	S	T	U	V	Z
115	67	M6	64	154	6	55	35	93.5	94	M8
220	87	M8	78	210	15	67	67	127.5	114	M10
330	103	M8	95	236	12.5	70	85	145	143.5	M12
440	116.5	M10	122.5	320	12.5	100	100	192.5	161.5	M14
490	173	M12	152.5	370	12.5	130	135	230	190.5	M20

For design requirements, this optional feature is available only on models BA BB BF115, BA BB BF220, BA BB BF330, BA BB 440, BA BB 490. The figure below shows the position of the widened rectangular inlet on the pumping chamber, and the table shows, according to the model type, the dimensions of the inlet, as well as the dimensions of the LPDP.

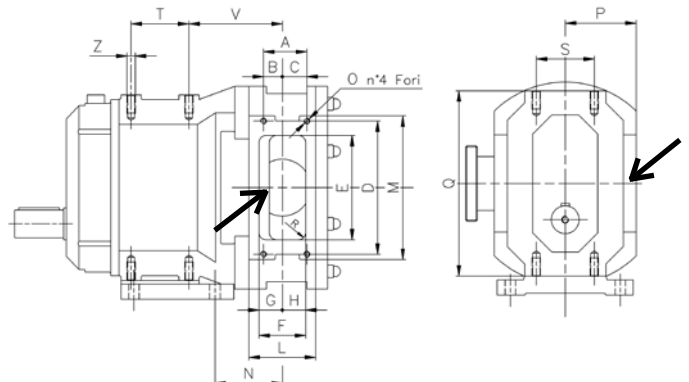

1.3.11 Bearings

The two tables to the side show, according to the pump size, the identity abbreviations of the bearings fitted on the transmission shafts of the LPDP, inserted in the LPDPG.

PUMP MODEL	PRE-ASSEMBLED BEARINGS	
	FRONT	REAR
105 110 115	32006X	
215 220	32008X	32007X
325 330 390	32010X	32008X
430 440	32014X	32012X
470 490	32016X	32014X

PUMP MODEL	ISO BEARINGS	
	FRONT	REAR
100	TLA 3020 Z	NATB 5904
	LRT 253020	

The front bearing has position number 29, whilst the rear bearing has position number 30, with reference to the exploded view of page 5 in this chapter.

- ⤴ The bearings of pump mod. BA BB BF 100 are ISO standard radial rollers type. The radial rear roller bearings combined with NATB 5904 oblique ball bearings, undergo an assembly adaptation to cancel the axial play.
- ⤴ The bearings of pump mod. BA BB BF 1 – BA BB BF 2 – BA BB BF 3 – BA BB BF 4 – BA BB 470 – BA BB 490 are made up of two metric bearings with a single row of conical rollers, by a spacer for the internal rings and by a spacer for the external rings. The assembly of the bearings is performed accurately by our technicians to ensure ideal rotation without play. For this reason, these bearings must be requested directly from O.M.A.C. s.r.l. that supplies them already pre-assembled with the right pre-load.
- ⤴ The duration of the bearings varies significantly according to the varying of the working conditions (speed, pressure, absorbed power) and therefore one cannot define it beforehand.

1.3.12 Lubricants used and quantities

The three tables show the general features of lubricant oil that can be used to lubricate bearings and sprocket wheels.

Tables A and B show the type of oil to be used according to the temperature of the processed fluid (from -20°C to +90°C, and from +90°C to +150°C): table A only refers to lobe displacement pump models BA BB BF100, BA BB BF105, BA BB BF110, BA BB BF115, BA BB BF215, BA BB BF220, BA BB BF325, BA BB BF330, BA BB 390, BA BB 430, BA BB 440, BA BB 470, BA BB 490.

The lines of the table that refer to "BRAND" list a series of possible suppliers where the lubricant can be bought.

PUMP MODEL	BRAND	WORKING TEMPERATURE	
		from -20°C to +90°C (oil viscosity ISO VG 68)	from +90°C to +150°C (oil viscosity ISO VG 150)
100 105 110 115 215 220 325 330 390 430 440 470 490	ESSO	SPARTAN EP 68	SPARTAN EP 150
	SHELL	OMALA OIL 68	OMALA OIL 150
	CASTROL	ALPHA SP 68	ALPHA SP 150
	BP	ENERGOL GR-XP 100	ENERGOL GR-XP 150
	MOBIL	MOBILGEAR 626	MOBILGEAR 629
	AGIP	BLASIA 68	BLASIA 150
	FINA	GIRAN 100	GIRAN 150

table A

PUMP MODEL	LITERS
100	0.2
105 110 115	0.5
215 220	1
325 330 390	2.2
430 440	4.5
470 490	6.7

table B

Table B shows the amount of lubricant, expressed in litres, to be inserted in the gear box, according to the pump size, and after having removed the previous exhausted oil, as described in chapter 5.

Should it be expressly requested by the customer, the BA BB BF series lobe pump can be equipped with alimentary type lubricant oil, NSF certified in H1 category.

1.4 Intended use

The BA BB BF Series Lobe Positive Displacement Pump Group, manufactured and marketed by O.M.A.C. s.r.l., which in this documentation will be indicated with the abbreviation LPDPG, has been designed and made to be assembled in industrial plants owned by third parties, to transfer volumes of fluids, compatible with the materials used during the construction of this machine: section 1.4.1 lists the recommended operational features of the LPDP, depending on the processed fluid.

The LPDPG requires compliance with all technical indications in this operation and maintenance manual, which in this documentation will be indicated with the abbreviation OMM, for its proper installation.

In general, the processed fluids must meet the following specifications:

Fluid properties and range of use:

- 1) TEMPERATURE: from -35°C to +180°C
- 2) VISCOSITY: Maximum 200'000cPs with forced feeding
- 3) HARD PARTICLE SIZE: Maximum 80% of clearance between rotors (see sect.1.3.4)

The LPDPG has been designed and made for two types of use:

- ▲ alimentary use;
- ▲ chemical use.



WARNING

The LPDPG, for alimentary use, has been made to ensure a hygienic standard equal to **LEVEL 3**, on the basis of **UNI EN 13951**.

The LPDPG for alimentary use and for chemical use has been designed to transfer volumes of fluids without altering the organoleptic properties nor the physical properties.



WARNING

During its normal use, the LPDPG for alimentary use and chemical use does not alter the organoleptic characteristics or the physical characteristics of the processed fluid.

Every LPDPG comes with a technical sheet indicating the operational features in relation to the processed fluid that must be handled (name of the fluid, viscosity range, capacity range, speed range, temperature range), as declared at the time of purchase by the Customer.

Section 1.3 shows a facsimile of the LPDPG technical sheet.

Every modification to what is indicated in the specific technical sheet or variation of the machine operating parameters must be authorised in writing by O.M.A.C. s.r.l.; the absence of such authorisation is deemed "improper use" and will void any warranty or liability under way between Manufacturer and Customer.



DANGER

Any use of the LPDPG in conditions other than those indicated in "Fluid properties and range of use" and in conditions other than those indicated in the machine technical sheet is forbidden, without explicit written authorisation, issued by O.M.A.C. s.r.l.

The LPDPG for alimentary use and for chemical use has NOT been designed nor built to handle pharmaceutical, explosive, etc. fluids, and in general fluids that do not comply with the indications of the specific technical sheet.

In addition, the LPDPG for alimentary use and chemical use has NOT been designed nor built to handle what is indicated in Regulation (EC) No. 1005/2009 of the European Parliament and the Council of 16 September, 2009, on substances that deplete the ozone layer.



ATTENTION

It is forbidden to use the LPDPG for alimentary use and chemical use to transfer the substances listed in Annex I of **Regulation No. 1005/2009**.

The pumping part of the LPDP is made up of the pump body, in which two rotors are housed (sect. 1.3.5 lists the types of rotors used), which rotate synchronised in the opposite direction to each other.

The rotorcase receives the process fluid from the suction inlet, originating from the plant of the Customer. During the operation of the LPDP, the cavities between the lobes of the rotors are filled with fluid and the counter-rotation of the rotors transfers the fluid to the delivery outlet of the pump body, channelling it in the plant where the LPDPG is installed.

1.4.1 Recommended use guidelines for the transfer of some types of processed fluid

As an example, the following table lists some types of fluids that can be processed by the LPDP, part of the LPDPG; for each one, we suggest a value or range of viscosity, fluid temperature, pump rotation speed, O.M.A.C. identification code of materials for seals, gaskets and rotors (see coding section 1.2.2).

The application requested by the customer is examined by the O.M.A.C. s.r.l. Technical Office, which edits the technical sheet of the LPDPG, specifically for the requested application.

Therefore, in all cases and without any exceptions, one must comply with the technical specifications, shown in the technical sheet of the LPDPG, these specifications have absolute priority over the data shown in the next table.



ATTENTION

On the basis of the features of the processed fluid, O.M.A.C. identifies and uses materials compatible with the proper processability of the fluid, and these features are specifically mentioned in the **technical sheet** of the LPDPG.

PRODUCTS	VISCOSITY cPs	TEMPERATURE °C	SPEED RPM	SEALS		O-RING	ROTORS	
				1°	2°		1°	2°
DAIRY PRODUCTS								
MILK	2	18	250-400	3	0	T	0	-
YOGHURT	50-150	20-40	250-350	6	3	T	0	-
BUTTER	50000	4	20-70	5	-	T	5	-
CREAM 30%	14	16	250-350	3	0	T	0	-
CURD	20-500	10	50-200	3	0	T	0	5
CONDENSED MILK	40-80	40	250-450	3	0	T	0	-

PRODUCTS	VISCOSITY cPs	TEMPERATURE °C	SPEED RPM	SEAL		O-RING	ROTORS		
				1°	2°		1°	2°	
CONDENSED MILK 75% S.S.	2000	20	200-400	5	3	T	0	-	
MELTED BUTTER	40	50	300-400	5	-	T	0	-	
PROCESSED CHEESE	30000-6500	18-80	200-400	5	-	T	0	5	
COTTAGE CHEESE	30000	18	50-150	5	-	T	0	5	
WHEY	1	20	300-500	3	0	T	0	-	
MILK ENZYMES	5	10	250-300	3	0	T	0	-	
FOOD PRODUCTS									
ICE-CREAM	400	10	200-300	5	0	T	0	5	
BROTH	1-400	20	250-450	5	3	T	0	-	
COCOA BUTTER	50-0.5	60-100	300-400	5	-	T	0	-	
ANIMAL FATS	60	40	250-400	3	-	T	0	-	
MEAT EXTRACT	10000	65	200-350	5C	-	T	0	-	
MAYONNAISE	20000	20	200-300	5	-	T	0	-	
MALT EXTRACT	3000-9500	18-60	200-300	5	1	T	0	-	
SUGAR CANDY	30000	20	150-250	5C	1	T	0	5	
MOLASSES	280-15000	40	150-300	5	1	T	0	5	
JAM	8000	16	200-350	5	-	T	0	5	
HONEY	1500	40	250-350	5	-	T	0	-	
WHOLE EGGS	150	4	200-350	6	5C	T	0	-	
BREWER'S YEAST	350	18	300-400	5	-	T	0	-	
SOYA LECITHIN	6000	50	200-300	5	-	T	0	-	
OLIVE OIL	40	38	250-350	5	3	T	0	-	
VARIOUS SEED OIL	20-60	20	250-350	5	3	T	0	-	
MINCED MEAT	100000	30	20-150	5	1	T	5	-	
PECTIN	300	30	300-400	3	5	T	0	-	
MAIZE PORRIDGE	100	100	100-200	1	0	T	0	-	
COOKIE PASTRY	5000-10000	18	50-150	5	-	T	5	0	
CHOCOLATE	200-2000	18-40	50-150	0	1	T	0	-	
ICING	500-2000	18	100-300	5	-	T	5	0	
BRINE	1	20	300-450	6	5	T	0	-	
TOMATO SAUCE	10	20	200-300	5	-	T	0	-	
DICED TOMATO	10	20	50-200	5	-	T	5	-	
TOMATO PURREÉ	7000	20	150-250	5	-	T	0	-	
TOMATO TRIPLE PURREÉ	12000	18	150-250	5	-	T	0	-	
TOMATO PASTE	200	18	200-300	5	-	T	0	-	
KETCHUP	1000	30	200-300	5	-	T	0	-	
DRINKS									
GLUCOSE	4300-8600	25-30	200-300	5C	-	T	0	-	
SORBITOL	200	20	250-350	5	-	T	0	-	
SUGAR SOLUTIONS	30° BRIX	4	10	300-400	5	-	T	0	-
	40° BRIX	10	10	300-400	5	-	T	0	-
	50° BRIX	25	10	300-400	5	-	T	0	-
	60° BRIX	60	18	300-400	5	-	T	0	-
	70° BRIX	550	18	250-350	5	-	T	0	-
	80° BRIX	6000	30	200-300	5	-	T	0	-
VINEGAR	15	20	300-500	3	-	T	0	-	
WINE	1	18	350-750	3	-	T	0	-	
SPIRITS	10-100	20	250-400	5	-	T	0	-	
ALCOHOL	1	18	300-500	3	-	T	0	-	
GRAPE JUICE	1	18	350-450	5	-	T	0	-	
BEER	1	18	300-400	3	-	T	0	-	
POTATO PUREÉ	400-4000	18	150-300	5	-	T	0	5	
FRUIT JUICE	20-80	18	250-400	5	-	T	0	-	
CONCENTRATED ORANGE JUICE	5000-500	5-20	200-300	5	-	T	0	-	

PRODUCTS	VISCOSITY cPs	TEMPERATURE °C	SPEED RPM	SEALS		ORING	ROTORS	
				1°	2°		1°	2°
COSMETICS AND PHARMACEUTICAL PRODUCTS								
DODECILBENZENSULPHONIC ACID	6000	18	300-400	5	-	V	0	-
DETERGENTS	100-4000	18	250-400	5	3	V	0	-
HAND CREAM	800-35000	20	150-350	5	3	V	0	-
SHAMPOO	2000	20	250-350	5	3	T	0	-
HAIR GEL	5000	20	250-350	5	3	T	0	-
NAIL POLISH	10000	20	250-350	5	-	P	0	-
SOAP	3000	20	150-250	1	-	V	0	-
TOOHPASTE	100000	18	50-150	5	1	V	0	-
HYDEROGEN PEROXIDE	1	15	300-400	7	5	V	0	-
GLYCERINE	600	18	250-350	6	4	T	0	-
VASELINE	30000-500	10-40	40-350	5	-	T	0	-
INDUSTRIAL PRODUCTS								
CITRIC ACID	1	20	300-450	3	-	T	0	-
SULPHONIC ACID	125	30	250-400	5	6	V	0	-
NEUTRALIZED ETHOXYL ALCOHOLS	200-600	60-30	300-400	5	-	P	0	-
ISOPROPYL ALCOHOL	1	20	300-400	3	-	U	0	-
FLAVOUR FOR TOBACCO	10-100	20	300-450	5	3	T	0	-
FERMENTATION SOUP	20	20	250-350	3	-	T	0	-
CELLULOSE	6000-15000	18	250-350	5C	-	P	0	-
WAX	500	93	200-300	5	-	T	0	-
VINYL GLUE	1500	18	200-300	5C	1	V	0	-
UREIC PHENOLIC GLUE	600	20	200-300	5C	1	P	0	-
LATEX EMULSION	200	20	300-400	5C	-	P	0	-
PARAFFIN EMULSION	3000	18	250-350	5	-	V	0	-
ETHYLENE	20	20	250-400	3	-	T	0	-
ETHYLENE GLYCOL	10	20	250-400	3	-	T	0	-
PRINTING INK	500-2000	35	300-500	6	-	V	0	-
FLUID SILICONS	500	40	300-400	5C	-	P	0	-
DYES	1-200	20	300-500	6	-	V	0	-
ACRYLIC RESIN	5000	20	200-300	5C	1	P	0	-
ALKYL RESIN	180-900	5-40	250-350	5C	1	V	0	-
VINYL RESIN	5500	20	200-300	5C	1	V	0	-

1.5 Material specifications

Below, listed per each component (bearings box, rear cover, rotorcase,..) of the LPDP, inserted in the LPDPG, are the materials the components can be made of.

COMPONENT	USED MATERIALS
BEARING HOUSING	CAST IRON GG25
GEAR COVER B1 B2 B3 B4 SERIES	ALLOY
GEAR COVER B5 B6 SERIES	CAST IRON GG25
PUMPING CASE	AISI 316 L or in optional: HASTELLOY C276; TITANIO GRADO 5; DUPLEX SAF 2507
SHAFTS	AISI 316 L or in optional: HASTELLOY C276; TITANIO GRADO 5; DUPLEX SAF 2507
ROTORS WITH STANDARD CLEARANCES	AISI 316 L or in optional: HASTELLOY C276; TITANIO GRADO 5; lega antifrizione CY5SnBIM
ROTORS WITH INCREASED CLEARANCES	AISI 316 L or in optional: HASTELLOY C276; TITANIO GRADO 5; lega antifrizione CY5SnBIM
RUBBER COATED ROTORS	Anima in AISI 316 L + optional one of the following elastomers: N.B.R., E.P.D.M., °VITON (F.K.M.)

1.6 Occupied workplaces

The LPDPG does not occupy any operator in a fixed manner. The operator occupies an occasional workplace and checks its proper operation as per the inspection and checking activity of the productive line the LPDPG is part of.

1.7 Indication of the safety systems

In order to reduce the risks associated with malfunctions or misuse, the LPDPG is equipped with the following security systems that are able to prevent / manage situations of danger for the operator:

- ⚠ fixed joint transmission guards;
- ⚠ emergency stop button;
- ⚠ seal protections (excluding the LPDP version with flushed mechanical seals or double mechanical seals).

As an optional feature, the LPDU can come with the full fairing. Below there are the above mentioned safety systems.

1.7.1 Flexible transmission coupling protection

The flexible transmission coupling is protected by a removable mechanical transmission device, made up of an even coverage, accurately shaped and made of AISI 304 or aluminium, which protects the operators from contact with the rotating parts.



DANGER

It is absolutely forbidden to operate the LPDPG if the safety devices have been removed.

1.7.2 Emergency stop

The emergency stop is a safety system made up of a red button, in the shape of a mushroom, on a yellow background and fitted on the electric panel, eventually supplied with the LPDPG. These buttons, when present and pressed, block the work cycle of the LPDP, stopping every movement in a few seconds: therefore they have no effect on stopping the work cycle of the plant the LPDPG is connected to. Therefore, to stop the operation of the plant, upstream and downstream from the pump, one must act on the plant emergency stop buttons.



DANGER

This emergency stop button IS NOT THE PLANT EMERGENCY STOP BUTTON.

To stop the operation of the plant, upstream and downstream from the pump, one must act on the plant emergency stop buttons. The emergency stop button can only be used in situations of severe and immediate danger, which require the immediate stop of all parts. Once the button has been pressed it will stay blocked until the operator performs its manual unblocking (by rotating it in the direction indicated by the arrow printed on the control), thus maintaining the LPDPG in a state of emergency.



DANGER

It is absolutely forbidden to operate the LPDPG if the safety devices have been removed. Damaged safety devices must be replaced immediately. Never neutralise the safety devices.

1.7.3 Seals protections

The seals protections, re. position 239, section 1.3, are laminations made of AISI 304 or resistant plastic and are applied with screws on the bearings box to protect the operator from contact with the rotating parts of the pump: in particular they cover the rear area of the pump body where the seals supports are fitted.



DANGER

It is absolutely forbidden to operate the LPDPG if the safety devices have been removed.

1.7.4 Optional features: full fairing

The full fairing of the LPDPG is made up of a cover made of AISI 304 shaped appropriately, according to the dimensions of the unit, and fully covers the transmission parts during their operation, in order to protect the operators present on the plant layout, where possible, from the accidental contact with the parts.



DANGER

It is absolutely forbidden to operate the LPDPG if the safety devices have been removed.

1.7.5 Optional features: Electric safety devices and pressure limiters

Upon specific request of the customer company it is possible to equip the LPDPG with two kinds of safety systems:

- ↗ pressure;
- ↗ electrical;

In particular the electrician called by the customer to perform this connection and qualified for the job, must design and make the electrical connections in compliance with the electrical regulations in force.

The electrician called by the customer to carry out the connections above must also envision a general reset function after the activation of the emergency state.



DANGER

It is absolutely forbidden to perform maintenance or repairs interventions on the LPDPG, without having worn the PPE.



DANGER

It is absolutely forbidden to operate the LPDPG after the occurrence of faults or malfunctions of the pump or equipment or devices connected to it. Damaged safety devices must be replaced immediately. Never neutralise the safety devices.

Never carry out any type of maintenance intervention directly, always contact the maintenance manager. Only this person is qualified to carry out maintenance operations professionally and in safety conditions. Before carrying out maintenance activities on the LPDPG, ensure that there are no danger situations and that the machine and plant it is connected to are in emergency stop conditions.

1.8 Noise and vibrations emitted

In the envisioned conditions and methods, the sound level test was carried out to define the noise value emitted by the LPDP. The sound level test of the LPDP was performed using water as process fluid, and using the O.M.A.C. pumps testing plant.

The sound level values detected were determined applying standard EN12639 and adopting the measuring specifications of ISO 3746, and are the following:

- ✦ Sound power level equivalent to 2 meters distance in work: 65 dB(A).



DANGER

It is absolutely forbidden to perform maintenance or repairs interventions on the LPDPG, without having worn the PPE.

PPE	RISK	USE	EXPOSED PERSONNEL
Shoes with reinforced toe caps and non-slip soles	Lower limbs crushing	always	maintenance operator / operator
Coated safety gloves	cuts and abrasions to upper limbs	during installation or use of the unit	maintenance operator / operator
Safety goggles	Dust	during installation or use of the unit	maintenance operator / operator
Filtering face mask	exposure to chemical agents	maintenance or cleaning	maintenance operator
Neoprene safety gloves	exposure to chemical agents	maintenance or cleaning	maintenance operator
Work clothes	Dust, entangling	always	maintenance operator / operator
Ear plugs	Noise	use of the pump unit	operator



ATTENTION

To prevent mechanical risks, such as dragging, entrapment and other, do not wear accessories such as bracelets, watches, wings or chains.

1.10 Personnel training

The LPDPG is made in such a manner to enable use directly by qualified personnel, for this reason one does not envision training periods, however the user, before performing any activities, must:

- ✦ carefully read this use and maintenance manual, paying attention to chapter 4, "Use of the machine",
- ✦ supervise routine maintenance operations;
- ✦ supervise the proper use of the LPDPG;
- ✦ check the protection devices work.



DANGER

Children, disabled persons, persons with by-passes or cardiac problems are not admitted as operators.

Therefore it is up to the customer to train the personnel appointed to use the machine, before it is commissioned.

The operator must have a technical professional qualification, as well as suitable knowledge of general safety standards.

During the training course, the training level of the operator must be supervised by the customer company, which has the technical and organisational knowledge necessary to carry out such task.

As provided by the current regulatory framework on health and safety at work, the training process should be formalised directly by the customer.

1.11 LPDP optional features

1.11.1 LPDP in aseptic version

Excluding models BA BB BF100, one can make the LPDP, included in LPDPG, in aseptic version (with steam or sterile liquid barrier on the cover), on the mechanical seals and openings. The aseptic LPDP is used in transfer processes of alimentary or chemical fluids which have undergone sterilisation and must not be contaminated in any way during transfer.

In the figures below there are the indications of inlet holes (A, C, E) and outlet holes (B, D, F) of the sterile liquid or steam inside the openings (A, B, E, F) of the pumping body and the cover of the pump body (C, D). For the seals consult section 1.3.9.

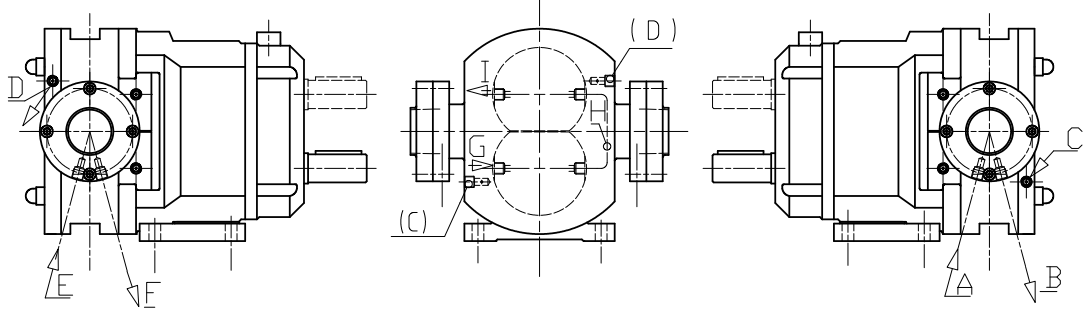

1.11.2 LPDP with widened rectangular inlet

Models BA BB BF115, BA BB BF220, BA BB BF330, BA BB390, BA BB440, BA B490 can be made with a rectangular widened suction inlet to facilitate supply of the LPDP with very viscous products such as mixtures or thick mixtures with semi-solid pieces.

In these cases to facilitate the product to fall in, the pump is installed with openings in vertical axis directly under the hopper.

To connect the bare shaft pumps with vertical axis piping one must disassemble the foot of the pump (fixed for models BA BB BF100) and fix the gear box directly to the special feet that can be supplied upon request (already included in the "vertical base"). If the LPDP is supplied bare shaft (without control unit), check the proper position of the caps and oil level.

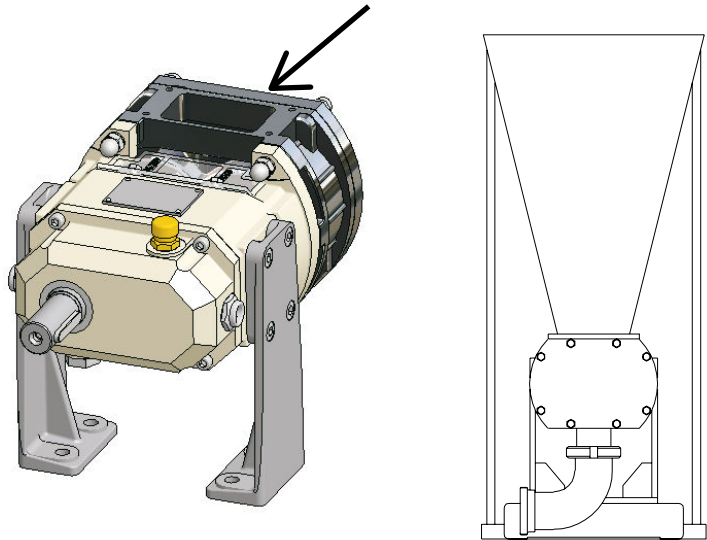

1.11.3 LPDP with rotorcase cavity and rotorcase cover cavity

In the event one wishes to maintain the pumped fluid at a constant temperature one can apply a cavity on the rotorcase and/or on the rotorcase cover for heating / cooling liquid circulation to all the pumps of the range (excluding BA BB BF100). Typical cases are the transfer of glucose, chocolate, melted fats, butter, margarine, and others.

For the dimensions of holes and the circuit diagram, consult the table in section 1.3.9.

The pipes and couplings for the circuit are not supplied with the pump.

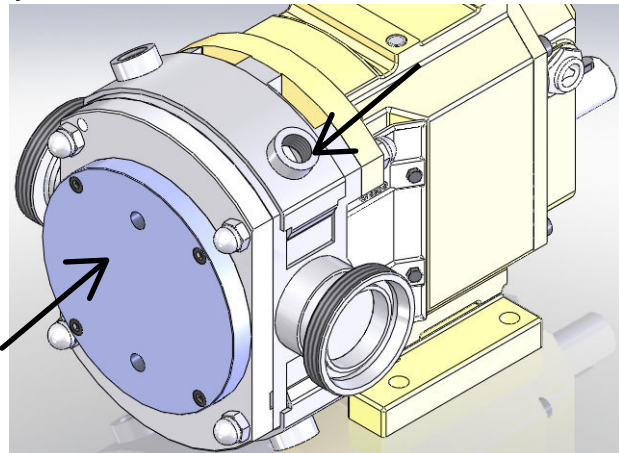

1.11.4 LPDP with mechanical safety valve on rotorcase cover

One of the possible versions of the LPDP envisions the possibility to fit a mechanical safety valve on the rotorcase cover, which intercepts and dampens any pressure peaks over the limit for which the valve is set.

- ✦ The safety valve, fitted directly on the front cover of the pump, is reversible and activated by a spring compressed by a regulator;
- ✦ The setting of the safety valve must be carried out on site by the Customer, because the entity of the recycling depends on the pump speed, on the specific weight and product viscosity.
- ✦ To prevent continuous vibrations, the safety valve must be adjusted in such a way that it starts working at a pressure 10% higher than the working pressure.

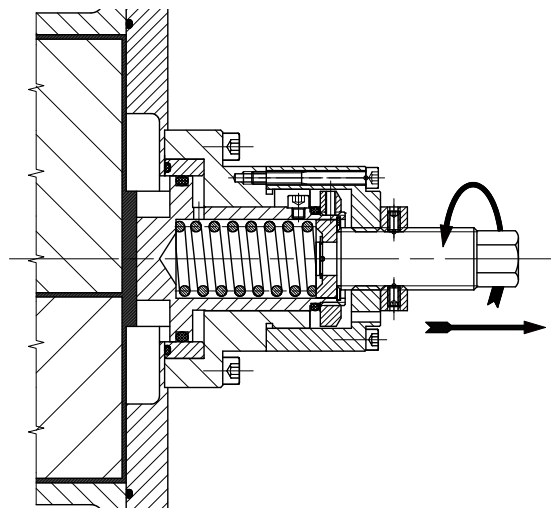

1.11.5 LPDP with pneumatic safety valve on the rotorcase cover

One of the possible versions of the LPDP envisions the possibility to fit a pneumatic safety valve on the rotorcase cover, which intercepts and dampens any pressure peaks over the limit for which the valve is set. The valve is fitted on the rotorcase cover and is made up of a cylindrical casing in which a piston slides. The fluid pressure (FP) acts on the piston face, whilst the pressure of the pneumatic plant (PP) acts on a plate fixed to the piston.

When the force that the air exercises on the plate is higher than that exercised by the liquid on the piston, the valve stays closed, otherwise the piston moves opening discharge volumes in the pumping chamber, that enable pressure balancing. Calibrating the by-pass means supplying the air chamber with a pressure value that keeps the valve closed until the pressure limit value in the pump reaches the desired value.

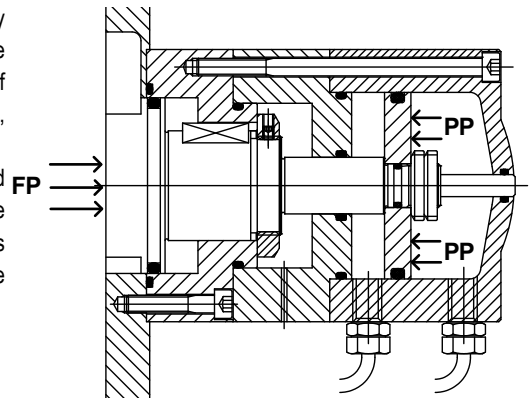

1.11.6 LPDP with external mechanical bridge safety valve

The external safety valve is made up of a spring valve positioned on a pipe bridge that connects delivery and suction and can also be used as a by-pass to recycle all or part of the pumped liquid. On this valve, the adjustment of the tightness pressure is up to a spring that can be more or less compressed. The system composed in this manner is one-way so if one inverts the direction of the pump, it is essential to invert the positioning of the valve as well that, in any case, must always be on the delivery side.

One can choose various kinds of springs according to the working pressure. The adjustment must be carried out manually on site on the appropriate adjustment ring.

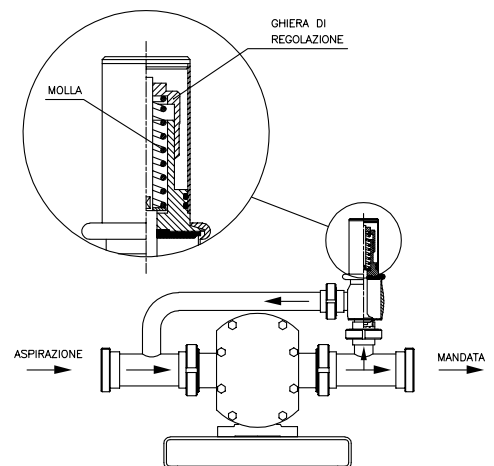

1.12 LPDPG optional features

1.12.1 Motorized LPDPG on fixed base

For customer needs, the motorized LPDPG can be assembled on a base made of AISI 304 or metal, to then be fixed, via bolts, to the floor.

The motorised LPDP on a fixed base is made up as follows:

- ✦ Support base made of press-moulded sheet metal;
- ✦ LPDP fixed to the base;
- ✦ Speed controller / gear motor / direct electric motor / hydraulic motor / pneumatic motor fixed to the base;
- ✦ Flexible mechanical transmission coupling;
- ✦ Flexible mechanical transmission coupling protection;
- ✦ Seals protections (excluding the flushed mechanical or double mechanical seals);
- ✦ Fairing (when envisioned in the pump unit supply, in this special version the mechanical transmission coupling protection is not installed).

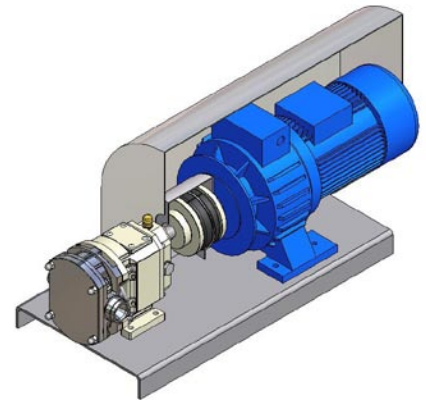

1.12.2 Motorized LPDPG on trolley base

For customer needs, the motorised LPDPG can be assembled on a base made of AISI 304 or metal, equipped with polyamide or pneumatic wheels and trolley transportation handle.

The motorised LPDPG on a trolley base is made up as follows:

- ✦ Trolley for unit transportation;
- ✦ LPDP fixed to the trolley;
- ✦ Speed controller / gear motor / direct electric motor / hydraulic motor / pneumatic motor fixed to the base.
- ✦ Flexible mechanical transmission coupling;
- ✦ Flexible mechanical transmission coupling protection;
- ✦ Seals protections (excluding the flushed mechanical or double mechanical seals);
- ✦ Fairing (when envisioned in the pump unit supply, in this special version the mechanical transmission coupling protection is not installed);
- ✦ Electric control panel (not present in the version shown in the figure).

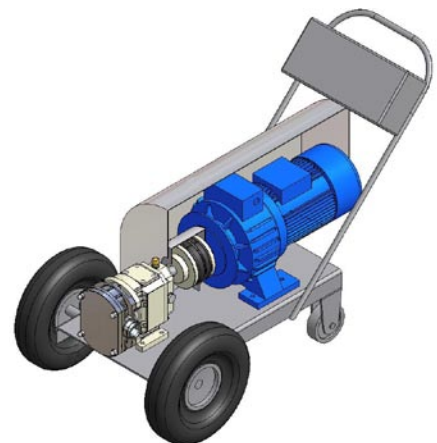

CHAPTER 2: TRANSPORTATION

In order to ensure safety of personnel involved and considering the peculiar features of the LPDPG, this can be handled only by personnel used to deal with heavy material and with the suitable hoisting equipment, complete with the relative hoisting accessories. For this reason only these people can recognise and exclude dangers for third parties and/or for the handled material.

Below there is a table illustrating the mass of the various LPDPG models.

BA BB BF LPDPG MODEL	BA BB BF LPDPG WEIGHT (kg.)	TYPE OF BELTS FOR LIFTING
100	40	CHECK THE WEIGHT TO BE LIFTED
105 110 115	80	
215 220	130	
325 330 390	220	
430 440	350	
470 490	550	



DANGER

The LPDPG has dimensions and weights that change according to its version and size. Take great care when handling and transporting. In particular, carefully follow all instructions for correct weight distribution.



ATTENTION

Pay the most attention during the pump unpacking operations, described further on.

2.1 Hoisting and transportation

The LPDPG is delivered to the customer inside a wooden crate (pack closed with screws; for further information please refer to section 2.4 of this operation and maintenance manual).

On the basis of the weight table indications, at the beginning of this chapter, crate handling can be carried out only with a forklift with suitable capacity, supplied by the customer and driven by personnel appointed by the customer, with the requirements needed to perform all operations in safety conditions. In addition the personnel must be used to handle delicate high-tech loads.



DANGER

It is absolutely forbidden to handle the LPDPG without a forklift with suitable capacity and driven by a person authorised by the customer, with the appropriate legal requirements.



ATTENTION

The crate containing the LPDPG will be hoisted exclusively with a forklift.

To handle the crate, proceed as follows:

- ⤴ place the forks of the forklift in correspondence of the slits between the feet of the handled crate base; slowly position under the base of the crate, ensuring that the centre-line of the forklift corresponds to the centre-line of the crate;
- ⤴ hoist the LPDPG carefully by about 50 millimetres, checking it is parallel compared to the lorry bed;
- ⤴ reverse slowly, but evenly, until the whole crate is completely out of the way of the lorry bed;
- ⤴ lower immediately (very slowly and avoiding sudden stops when lowering) until the forks of the forklift are about 50 millimetres from the ground;
- ⤴ proceeding very slowly and carefully, put it in position.

Once the crate has been handled, one must place it near the LPDPG installation area, in order to reduce any risks deriving from the manual handling of weights.



DANGER

During hoisting and transportation operate with great caution, in order to prevent damage to people or things.

**DANGER**

During hoisting and transportation ensure that there are no exposed persons in a dangerous area.

2.2 Delivery and unpacking**a. Delivery**

All the material supplied to the customer is accurately checked by O.M.A.C. s.r.l. before shipment. Upon receipt of the LPDPG ensure that the material has not been damaged during transport and that the package has not been tampered with resulting in removal of parts from the inside. If one finds the package is damaged, immediately notify the carrier and O.M.A.C. s.r.l. producing photographic documentation.

**WARNING**

With reference to the table at the beginning of this chapter, the weight of the LPDPG can vary according to its version and dimensions of the products it is made up of. The units must be handled using hoisting equipment, complete with the relative accessories.

b. Unpacking

Take utmost care during the unpacking operations of the LPDPG and complete the following steps:

- ▲ Open the crate, using an electric screwdriver to remove the fixing screws of the crate lid;
- ▲ Carefully remove the packaging from the LPDPG;
- ▲ Check if the LPDPG has any visible signs of damage;
- ▲ Place the packaging in the warehouse;
- ▲ Ensure that there are the protective plastic caps closing the connections openings;
- ▲ Ensure that the equipment supplied with the LPDPG is not damaged.

In the event there is damage or parts are missing, immediately notify the carrier and O.M.A.C. producing photographic documentation.

Unless otherwise indicated the LPDPG is shipped fully assembled, protected by a nylon sheet and set in a wooden crate. Fixing is achieved with four wood screws (see table in section 2.4); positioned in the appropriate pre-drilled holes on the LPDPG support base. Should the user need to transport the LPDPG one must restore the conditions described above.

**WARNING**

Keep the LPDPG packaging with care, during its entire operating period. The original packaging is needed for a possible transfer of the LPDPG, after its first installation.

2.3 Conditions for storage or extended interruptions of service

The LPDPG has been designed for immediate use, however if the machine down time conditions should occur for long periods, one must:

- ▲ disconnect the LPDPG from the electrical mains;
- ▲ following the instructions in this OMM, disconnect the LPDPG from the plant it is connected to; close the suction inlets and delivery outlets with the supplied closure plugs.
- ▲ with reference to chapter 5 remove the seals and see to cleaning and sanitising them;
- ▲ lubricate and clean the seals, the pump body and the parts contained;
- ▲ put the LPDPG back in its original packaging, as instructed in section 2.4, covering the electric supply and control panels with particular care;
- ▲ place the LPDPG on scaffolding with suitable capacity to support the weight of the LPDPG, avoiding putting weights on top of the machine;
- ▲ store the LPDPG in a dry place, in its original packaging, positioning it according to the instructions shown on the crate;
- ▲ store it at a room temperature above +5°C and below +30°C, and keep it in a sheltered place away from weather or other.

**WARNING**

Place the LPDPG back on the scaffolding with suitable capacity to support the weight of the LPDPG.

**WARNING**

In order to keep the features of the LPDPG unvaried, one must comply with all the instructions above and it is recommended to avoid particularly damp environments.

2.4 Packaging composition for future handling

In the event of transferring the LPDPG, after its first installation, one must use its original transportation crate.



ATTENTION

To transport the LPDPG, use the original O.M.A.C. transportation crate.

Fix the LPDPG with the appropriate fixing screws, to the wooden base, placing a nylon sheet between the wooden base and the unit.



ATTENTION

Place the nylon sheet between the wooden base and the LPDPG, to protect the machine from dust.

Subsequently, fit the external panels and lid on the sides of the base, which will make up the transportation packaging of the LPDPG. Below in the figure there is a typical example of the LPDPG packaging.

In cases where the legislation in force requires it, one must use wooden crates that have undergone fumigation treatment.

TYPICAL PACKAGING DELIVERED	
LENGHT X WIDTH X HEIGHT of the CRATE (rif. dis. cassa Z x X x Y)	WEIGHT (kg)
36 X 26 X 39	5
45 X 35 X 44	7
65 X 43 X 54	10
76 X 42 X 64	13
86 X 61 X 74	19
100 X 42 X 53	16
120 X 80 X 117	45
130 X 53 X 64	20
160 X 63 X 74	31
160 X 63 X 135	41
200 X 71 X 104	51
230 X 72 X 95	61

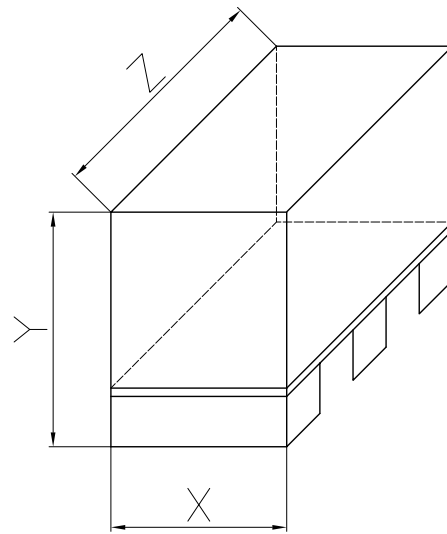

2.5 Handling the LPDPG without packaging



ATTENTION

If the LPDPG is equipped with the full fairing, before carrying out hoisting operations one must "disassemble" the fairing by unscrewing the hexagon screws that fix it to the support base.

To handle and hoist the LPDPG without packaging, it is recommended to use hoisting equipment, complete with the relative accessories, with minimum capacity suitable for the machine to be hoisted (for weights consult the table below). Hoist and handle the pump Unit as indicated in the figure.

Only the BA BB BF100 model LPDPG can be handled and hoisted by hand as its maximum weight is 30 Kg. To carry out the mentioned operations use belts with adequate capacity (not supplied).



DANGER

It is forbidden to use worn hoisting belts.

All LPDPG handling operations must be carried out by personnel authorised by the customer. The authorised personnel must know how to use the hoisting equipment. He must:

- ▲ use hoisting belts that are not worn;
- ▲ arrange and wrap the belt around the LPDPG, as indicated in the figure on the following page;
- ▲ stretch the belts delicately;

- ▲ ensure that the belts do not strain and that their position around the LPDPG does not move when hoisting; in the event there is a speed controller fitted, make sure that the belts do not strain on the control hand-wheel;
- ▲ hoist the LPDPG from the ground by about 20 - 25 cm and move it to installation place.

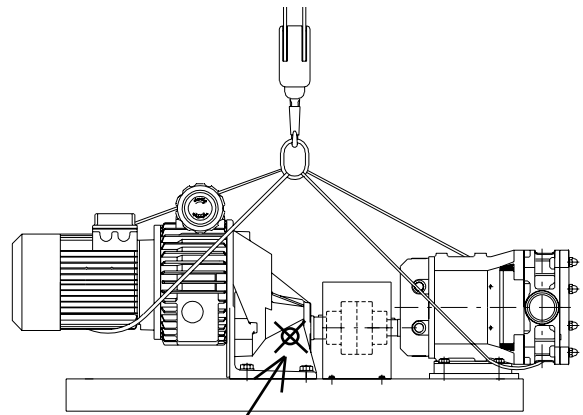

The position of the centre of mass is indicative because it depends on the configuration of the LPDPG. ☒ = center of mass



WARNING

IT IS ABSOLUTELY FORBIDDEN TO HOIST THE LDPU WITH METHODS OTHER THAN THOSE INDICATED.

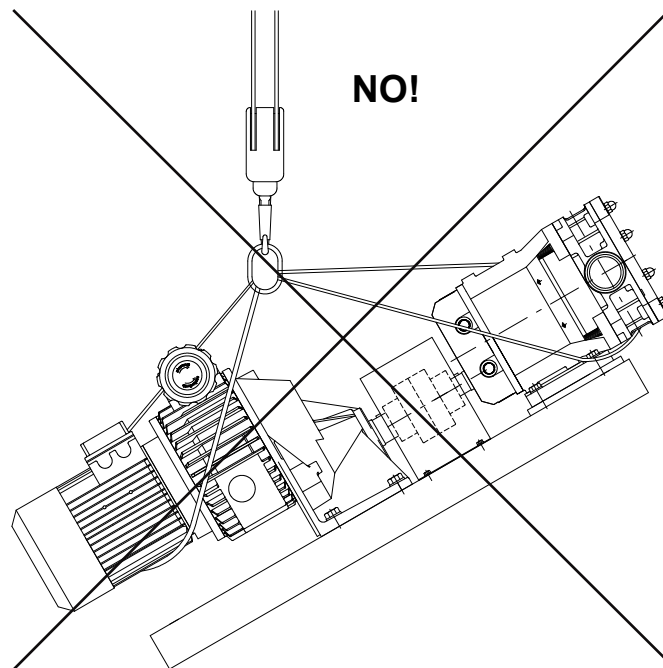

CHAPTER 3: INSTALLATION

Before carrying out any intervention on the LPDPG, read and understand this chapter in full. The operators responsible for the assembly/installation activities must have good familiarity with this type of equipment and possess recognised technical skills acquired in at least three years of similar activities, this experience is essential to limit and reduce the risks involved in assembly/installation activities.

Good knowledge of the systems and components of the LPDPG is essential before carrying out any operation.



DANGER

Assembly and disassembly operations of the LPDPG, performed incorrectly and/or differently from the instructions herein, could be extremely dangerous and cause injuries.

Only use the tools and utensils listed in this manual; furthermore during assembly and disassembly operations one must wear personal protection equipment, listed in section 1.9 of chapter 1.

3.1 Destination an intended environments

In order to ensure maintaining the hygienic levels required by the customer, one must install the LPDPG in closed work environments, whose features comply with the requirements of this manual; the floor must be level, made of concrete, without bumps and solid enough not to collapse.

In the event the LPDPG is supplied for alimentary use, the work environment must meet specific hygiene regulations requirements.



ATTENTION

The LPDPG must be installed in closed work environments, not exposed to weather.



ATTENTION

Installation of the LPDPG for alimentary use and its place of use must comply with the hygienic and sanitary standards required by the legislation in force.

In order to facilitate installation, use, sanitisation and maintenance of the LPDPG, the Customer must prepare a space free from obstacles, with a free area of at least 3 m².



ATTENTION

A work space below 3 m² may lead to incorrect installation of the LPDPG as well as non-functional and easy maintenance.

3.2 Environmental conditions

The LPDPG gives maximum performance when used in work environments that meet the following work conditions:

RELATIVE HUMIDITY BELOW 50%
ROOM TEMPERATURE BETWEEN +5°C AND +40°C



ATTENTION

IT IS FORBIDDEN TO USE THE LPDPG IN ENVIRONMENTAL CONDITIONS OTHER THAN THOSE INDICATED ABOVE.



ATTENTION

ONE PROHIBITS ALIMENTARY USE OF THE LPDPG IN ENVIRONMENTS THAT DO NOT MEET THE HYGIENIC AND SANITARY STANDARDS REQUIRED BY THE LEGISLATION IN FORCE.

3.2.1 Room lighting

The Customer must ensure suitable lighting of the work area, as required by EU Directives and the work legislation in force.

So not to cause reflections that can distract and dazzle workers or prevent, even partially, reading the control panels and signals, when provided by the LPDPG configuration, we recommend using a diffused light.



NOTE

For maintenance and repairs interventions on the machine it is recommended to use a portable battery torch, which can be orientated in the most appropriate direction depending on the kind of intervention.

3.3 Installation and assembly

The assembly and installation of the LDPU must be performed only by qualified personnel, authorised by the Customer in compliance with the standards in force, as well as observing the instructions supplied below.

**ATTENTION**

Depending on its use, it is responsibility of the Customer to equip the installation room in order to comply with the safety and hygiene standards in force.

To operate, the LPDPG needs to be connected to some utilities, such as for example:

TYPE OF UTILITY	USE
Company electrical system	electrical panel and control panel (if present) + earthing
	electric motor (in absence of control panel)
Hydraulic unit	optional features such as: hydraulic motor, seals flushing circuit
Pneumatic system	optional features such as: operation of the pneumatic safety valve
Customer plant	transfer of processed fluid
Sanitising steam system	optional features such as: aseptic version

3.3.1 Notes for the installer

Before proceeding with the installation operations of the LPDPG, the installer responsible for these operations must make sure that the plant of the Customer has previously been cleaned with a piping washing cycle. during this cycle, the suction connection inlet of the plant must be connected directly to the delivery outlet of the plant, in order to carry out the preliminary washing and cleaning cycle.

This operation enables to eliminate all solid residues (dust, processing or welding scraps, etc.), produced during the pipes assembly stages, which may lead to malfunctioning of the LPDPG, such as possible rotor seizing.

Please note that the machine supplied by O.M.A.C. s.r.l. does not require preventive cleaning before use.

**NOTE**

The pipes cleaning and washing operation must be carried out whenever the Customer appoints the installer to perform changes on the plant, such as inserting manometers on the line, fittings or other, in order to ensure the elimination of solid particles that would lead to malfunctioning of the LPDPG. THE LPDPG MUST NOT UNDERGO THIS CLEANING CYCLE, MEANING THAT THE INSTALLER MUST CONNECT THE UNIT SUCTION PIPING DIRECTLY TO THE DELIVERY PIPING, THUS EXCLUDING THE LOBE POSITIVE DISPLACEMENT PUMP.

In addition, before production it is essential to carry out cleaning activities, as described in section 3.4.

3.3.2 Preliminary checks

To start installation activities, one must carry out some preliminary checks, relating to the work environment (with reference to section 3.2) and to the integrity of the product (with reference to section 2.2).

If this inspection should highlight the non compliance with the requirements, the Customer must:

- ⚠ in the event of environment inadequacy, proceed to meet the requirements;
- ⚠ if there is damage or non-compliance with the order, immediately notify O.M.A.C. s.r.l., producing photographic documentation;
- ⚠ make sure that the utilities, listed above, are near the LPDPG installation place and that they meet the requirements of section 1.3 and what is contained in the technical sheet.

**ATTENTION**

Failure to comply with the indications of section 1.3 and the technical sheet, may lead to anomalous operation of the LPDPG (excessive noise, vibrations, etc...) or malfunctioning that can cause mechanical damages.

The Customer is responsible for the installation and proper operation of the LPDPG as well as compliance with the indications of section 1.3 and the technical sheet.

- ⚠ ensure one can connect the LPDPG to a plant that meets at least the hygienic standard of the LPDPG, as shown in the declaration of conformity attached to this manual;
- ⚠ ensure that the Customer plant is, from the dimensional point of view, satisfactory for the requirements of the LPDPG (suction-delivery openings dimensions, piping diameter, height from the ground, unit dimensions, adequate N.P.S.H. (Net Positive Suction Head) available, linear piping to prevent back-flow, etc.)
- ⚠ make sure that the paving or metallic structure on which the LPDPG will be installed has a suitable capacity for supporting the weight of the unit;
- ⚠ make sure there is enough work space, free from obstacles, with a free area of at least 3 m² that ensures the execution of all needed operations in complete safety conditions for the operator.

3.3.3 Installation

Below there are the activities that one must carry out, for safe and efficient installation. In particular, the instructions are divided in simple stages, as described below:

STAGE 1: PLACEMENT

Following the provisions of section 3.3.1 - Preliminary checks - and on the basis of the indications of chapter 2 of this use and maintenance manual, the operators must see to harness and handle the LPDPG to place it in the position required by the Customer and specified in the plant layout.

During this stage, one will need to use a forklift with suitable capacity, driven by personnel appointed by the Customer, as per chapter 2. One must pay utmost attention in placing the LPDPG in the envisioned position without intervening on the unit piping.

In the LPDPG version with adjustable feet, the operators will see to measuring the height of the suction and delivery piping of the unit, after having positioned the machine. Then they must adjust the height of the unit openings at the measured height, acting on the adjustable feet. Once the second operation is complete, they can free the unit from the harnesses and proceed with stage 2 - fixing and installation, hooking the openings of the unit pumping part by screwing them onto the plant piping.



ATTENTION

Check that there are the special non-slip rubber rings in the feet.



ATTENTION

Ensure the Customer plant is aligned properly with the suction and delivery openings of the LPDPG.

When installing the LPDPG it is essential to leave a enough space for maintenance and possible removal.

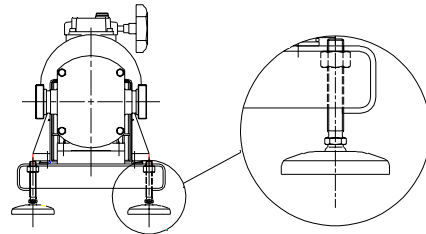

During **STAGE 1** relating to the **POSITIONING** it is recommended **to avoid the followings situations:**

- in the event there are horizontal tracts of suction piping, make sure these are slightly inclined upwards to prevent air pockets from forming which would inhibit perfect priming of the LPDPG;

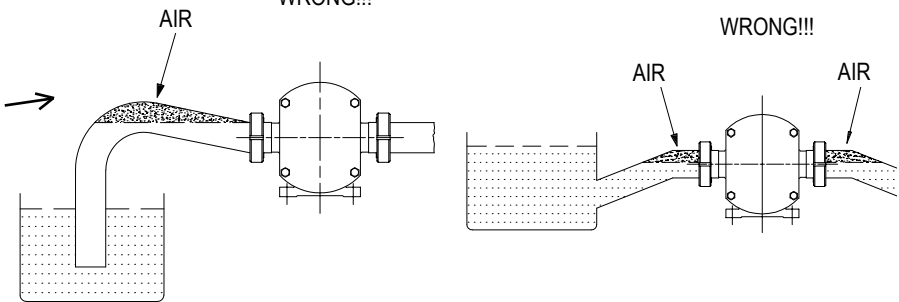

- if the LPDPG is not under the head, in the suction tract provide a foot or check valve to maintain priming;

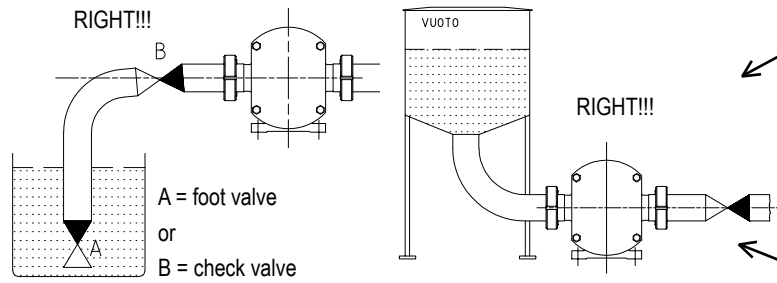

- if the LPDPG is connected to a vacuum tank, one must reduce the load leaks due to the suction piping as much as possible;

- when applying in vertical position avoid connecting the suction inlet to the lower side and the delivery outlet to the upper side. The proper configuration consists in connecting the suction pipe to the upper side and the delivery pipe to the lower side.

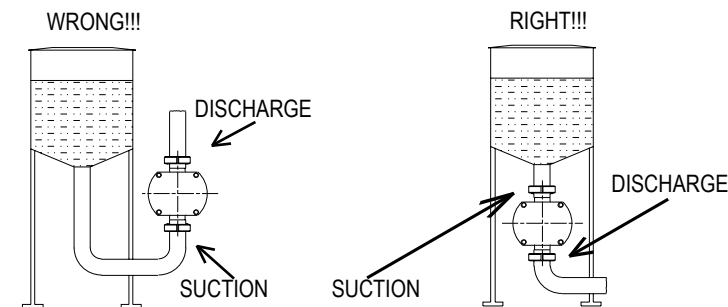

- install a check valve on the delivery tract to prevent the back-flow of air or liquid during interruptions of service in order to maintain the pipes completely full and to facilitate starting when loaded.

STAGE 2: FIXING AND INSTALLATION ON SITE

Once the LPDPG has been positioned and aligned to the Customer plant, proceed to fix and install in the plant. Since fixing between the plant and the LPDPG involves the suction inlet and delivery outlet of the pumping body, listed below are the maximum values of forces and moments, indicated with EF and EM, which the pump body and consequently the LPDPG, of which it is a part, can sustain, as maximum values, during standard operation.

PUMP TYPE	FORCES [N]				TORQUES [Nm]			
	Fx	Fy	Fz	EF	Mx	My	Mz	EM
SIZE 100	65	55	75	113	110	85	70	140
SIZE 105-110-115	105	95	120	186	125	100	90	164
SIZE 215	145	130	160	252	130	110	95	172
SIZE 220	190	180	220	342	140	115	100	183
SIZE 325	210	200	250	383	150	120	110	197
SIZE 330-390	240	230	280	435	160	130	110	206
SIZE 430-440	255	245	300	464	175	150	130	230
SIZE 470-490	260	250	305	472	180	150	130	234

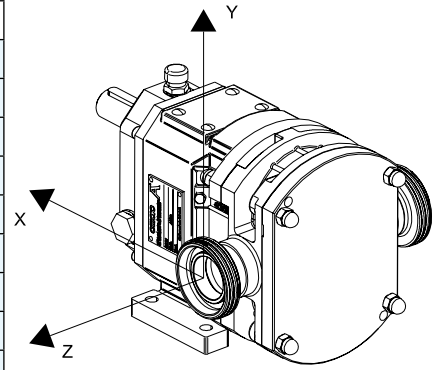

STAGE 3: CONNECTION TO THE PLANT

The suction inlet and delivery outlet of the LPDP, included in the LPDPG, are sized for the passage of even very viscous products, consequently the pipes do not necessarily need to be proportionate to them.

The suction and delivery pipes must be sized according to the calculations indicated in the O.M.A.C. technical manual, in relation to capacity, viscosity and pressure loss that one wants to achieve.

Displacement pumps can operate with significant pressure losses in delivery, but not in suction where it is recommended to use pipes as large and short as possible to maintain the NPSH required by the pump, part of the LPDPG, lower than the NPSH available in the plant of the Customer.

The LPDPG must always be installed as close as possible to the source from which it must suck up.

During **STAGE 3** relating to **CONNECTION TO THE PLANT** it is recommended to avoid the following situations:

- ⚠ reduce the amount of bends and narrowing as much as possible all along the line;
- ⚠ using long range bends avoiding to use "T" fittings and avoid unnecessary runs.
- ⚠ check the complete air tightness of the suction fittings in order not to decrease the suction power of the pump.
- ⚠ The weight of the piping must not rest on the pump body and it must be connected without using force to prevent overload and distortion of the pump body.

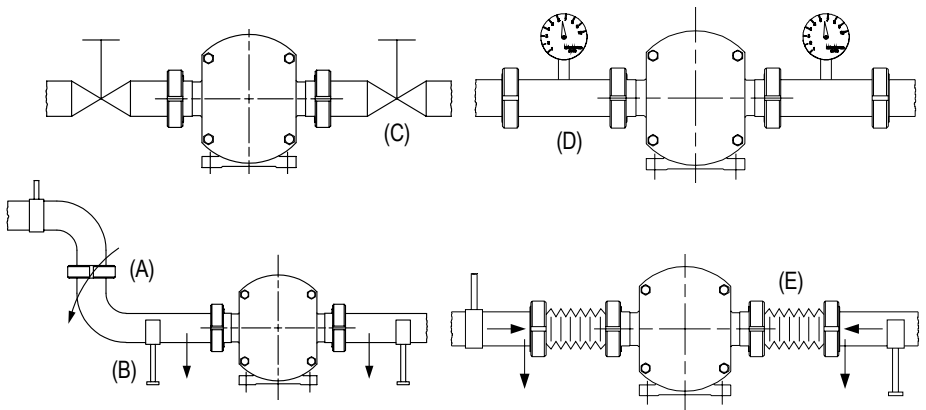

- ⚠ In the case of very long piped, install a gate on the inlet and one on the outlet of the pump, to facilitate inspection without emptying the whole unit uselessly.
- ⚠ it is recommended to fit manometers and vacuum gauges as close as possible to the pump. They will be very useful to check the standard operation conditions of the pump and diagnose any inconveniences such as: pressure overloads, absence of fluid, work conditions instability, cavitation.
- ⚠ protect the pump from hard solid bodies entering. Where possible install a suction filter: the filtering area must not be less than 4-5 times the pipe section to minimise pressure losses.
- ⚠ where possible, fit flexible expansion joints to reduce vibrations and prevent forcing due to thermal dilations of the pipes.

STAGE 4: FIXING THE LINE AND COMPLEMENTARY PROTECTIONS

The LPDPG can be fixed in three ways, described below:



ATTENTION

If the LPDPG has been supplied in the full fairing version and the fairing, or other parts of the unit, have been removed to facilitate on site positioning operations of the LPDPG, one must re-fit these parts on the LPDPG before completing the fixing operations of the unit.

a) Fixing onto a metallic structure.

If one must fix the LPDPG to a metallic structure, use the special pre-drilled holes on the support base. With ref. to the following drawings, for the distances between the holes and the dimensions of bolted connections to use, see the table below, where for every kind of base size and its measurements "A" and "B", there are the sizes of the bolts for fixing to the metal structure

SUPPORT SIZE	A	B	DOWEL SIZE
0	220	590	M12
1	220	590	M12
2	270	720	M12
3	330	920	M16
4	400	1100	M20
5	500	1400	M20
6	500	1400	M20
7	180	460	M10
8	450	1250	M20

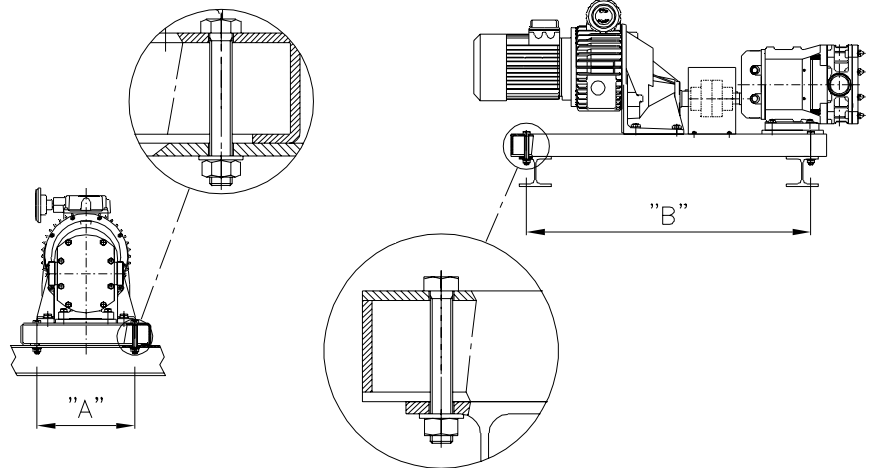

ATTENTION

In the case the LPDPG is installed at a height, one must provide a containment tank for any loss of fluid or lubricant liquid, due to malfunctioning.

b) Fixing on a concrete base.

If one needs to fix the "B series lobe displacement Pump Unit" on a concrete base use the special pre-drilled holes on the support base. For the distance between holes and the dowels to use, see the table below and the instructions supplied by the dowels manufacturer.

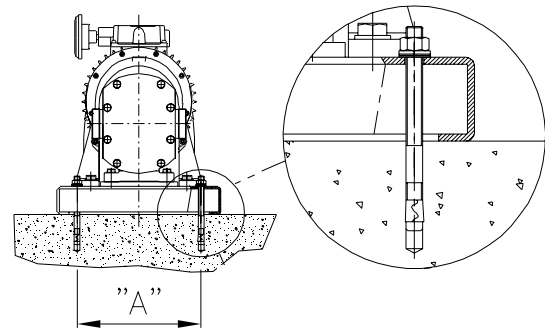

c) Support with adjustable feet

Upon explicit request of the user, the "B series lobe displacement Pump Unit" can be supplied with four adjustable feet fixed to the support base.



ATTENTION

Check that there are the special non-slip rubber rings in the feet.

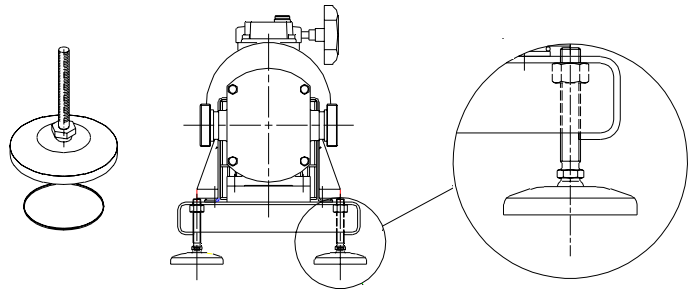

3.3.4 Accessories fitting

The LPDPG can come with the following optional accessories:

- a) mechanical safety valve on the cover of the pumping body (suitable for alimentary use);
- b) pneumatic safety valve on the cover of the pumping body (suitable for alimentary use);
- c) external bridge mechanical safety valve (suitable for alimentary use);
- d) seals flushing circuit;
- e) aseptic liquid circuit;
- f) heating/cooling circuit on the cover of the pumping body or on the same pumping body.

When the LPDPG is for alimentary use the assembly or replacement operations of the accessories, listed above, must mandatorily be followed by the sanitisation procedures described in section 3.4 of this chapter, in order to restore the hygiene and safety level required (Lev. 3 of EN 14159).

These optional features must be order together with the LPDPG becoming an integral part of it. Chapter 1 gives the technical specifications of the optional features listed above, below there are the methods for adjusting or connecting the LPDPG to the relative supply circuits. These operations must always be carried out after installation (re. section 3.3.2) and therefore the indications below assume proper installation and connection to the energy sources.

ATTENTION

The adjustment of the mechanical and pneumatic safety valves, described below, must be carried out by the operator in charge, before commissioning the LPDPG.



ATTENTION

The adjustment of the mechanical safety valve must be carried out on site by the Customer, since the recycle entity depends on the LPDPG speed, on the specific weight of the fluid, as well as its viscosity.

A) MECHANICAL SAFETY VALVE AND ADJUSTMENT

The mechanical safety valve is made up of a cylindrical shaft in which a piston slides, on which a load spring is fitted.

The mechanical safety valve is fitted directly onto the front cover of the pump (pump body cover) and its purpose is to intercept pressure peaks of the fluid in suction, allowing part of the processed fluid to recirculate in the pumping chamber.

The adjustment of the safety valve is achieved by adjusting compression of the spring (pos. 71) and on the adjustment screw (pos. 59). The adjustment of the spring establishes the pressure value at which the mechanical safety valve opens and this adjustment must be carried out on site, as the recycle entity depends on the pump speed, on the specific weight of the fluid, as well as its viscosity.

To prevent continuous vibrations, the safety valve must be adjusted in such a way that it starts working at a pressure 10% higher than the working pressure.



ATTENTION

It is recommended to adjust the mechanical safety valve at an opening pressure 10% higher than the LPDPG working pressure.



ATTENTION

The adjustment of the mechanical safety valve must be carried out on site by the Customer, since the recycle entity depends on the LPDPG speed, on the specific weight of the fluid, as well as its viscosity.

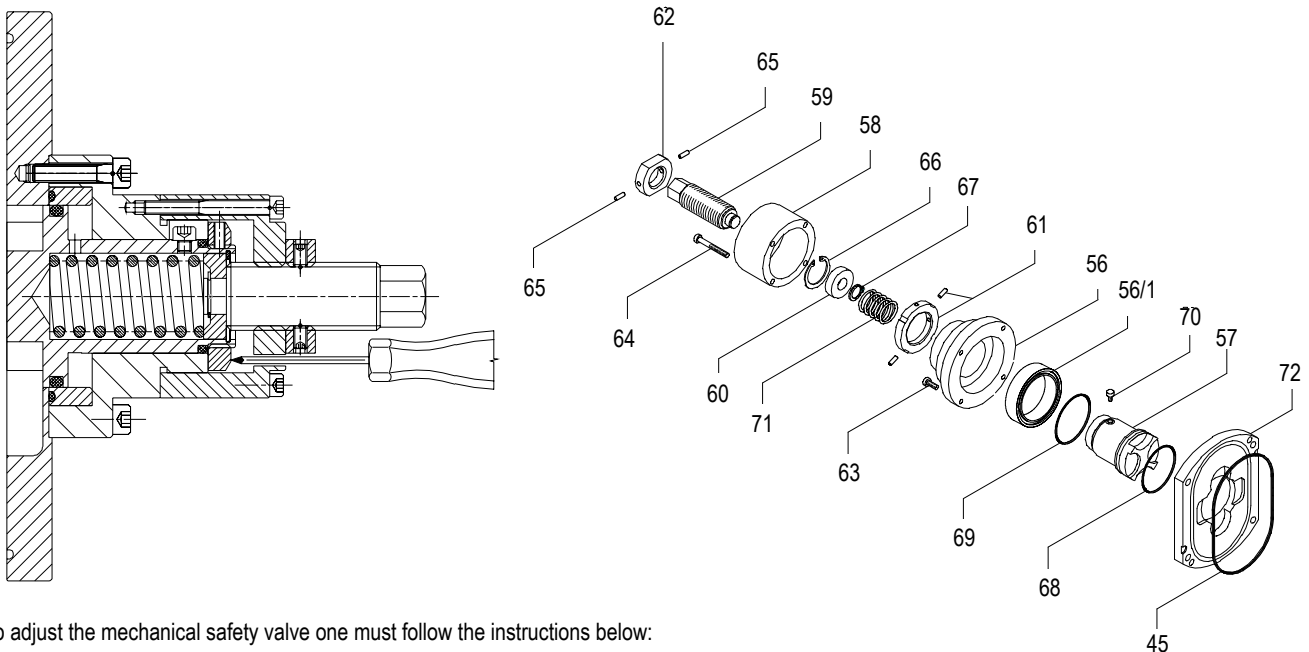

To adjust the mechanical safety valve one must follow the instructions below:

1. Completely unscrew the adjustment screw (pos. 59) in order to disable the valve.
2. Insert a thin rod in the inspection hole on the valve cover, pos. 58, until touching the ring.
3. Start the LPDPG with the safety valve spring loosened, i.e. not under pressure.
4. Using a screwdriver gradually tighten the adjustment screw (pos. 59 in the figure to the right), compressing the spring and checking that the pressure in the delivery outlet of the LPDPG does not exceed the allowed pressure.



ATTENTION

With reference to section 3.3.3, in order to calibrate the spring there must be appropriate manometers on the suction and delivery pipes that indicate the pressure in

1. Tighten the adjustment screw until the thin rod starts to move.
2. Compress the spring by 1/4 screw turn past the critical opening point to prevent vibrations.
3. Position the regulator retainer (pos. 62 in the figure below) and block it with the appropriate hexagon hollow bolt (pos. 65 in the figure below).

The mechanical safety valve can also be used in manual mode, to adjust the capacity: unscrew the adjustment screw (pos. 59), release the spring pressure until moving the piston away (pos. 57) from the pumping chamber, allowing part of the pumped liquid to return into the suction chamber. This operation is not allowed for volatile fluids, such as for example solvents and fluids sensitive to temperature increase, due to continuous recirculation of the same product. For products viscosity above 15000 cPs, if one must recycle all the pumped liquid it is recommended to install a by-pass on the line, adequately proportionate, in order to allow the passage of the entire flow of the LPDP.

B) PNEUMATIC SAFETY VALVE AND ADJUSTMENT

The pneumatic safety valve is made up of a cylindrical shaft in which a piston slides and it is fitted directly onto the front cover of the pump (pump body cover). Its purpose is to intercept pressure peaks of the fluid in suction, allowing a part of the processed fluid to recirculate in the pumping chamber. The safety valve is in contact, on one side, with the processed fluid, whilst inside it is balanced with the pressure from the pneumatic circuit.

The adjustment of the pneumatic safety valve is carried out on site because it must be connected directly to the compressed air circuit on site. To adjust it is recommended to use, as reference for the pressure and sizing of the compressed air unit, the graph below showing the correspondence between the pressure inside the pump and the pressure in the valve. To prevent continuous vibrations, the safety valve must be adjusted in such a way that it starts working at a pressure 10% higher than the working pressure.

When the force the pneumatic circuit exercises on the valve is higher than that exercised by the fluid, the valve stays closed; on the contrary the valve is activated generating discharge volumes that enable balancing of forces, inside the pumping chamber.

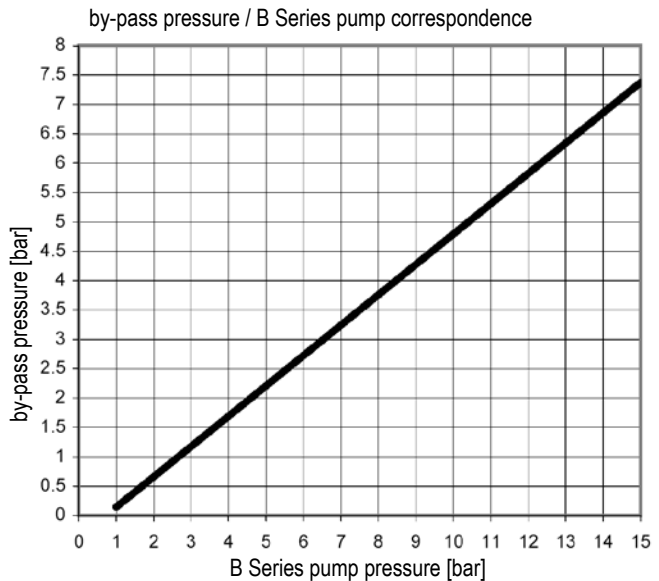
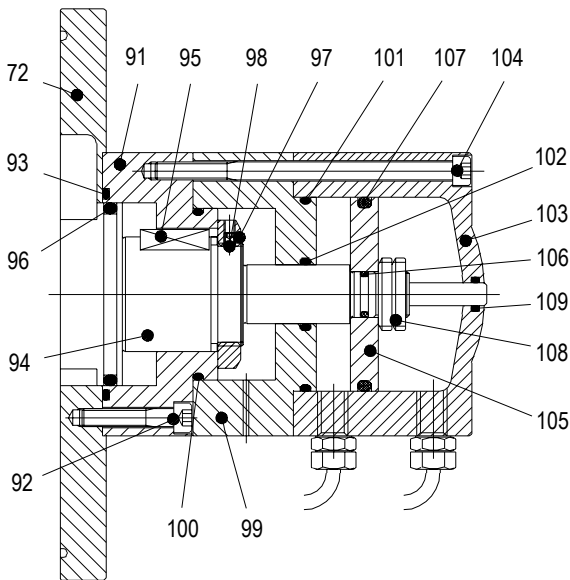

Before calibrating the pneumatic safety valve, one must calibrate the pneumatic circuit of the Customer, with a pressure value as follows:

- ▲ on the basis of the data carried in the LPDPG technical sheet, detect the unit working pressure;
- ▲ with this data consult the graph shown on the next page to obtain the pressure value with which the safety valve must be calibrated.

Once one has obtained these values, proceed as indicated below:

- ▲ start the LPDPG with the safety valve connected to the compressed air circuit;
- ▲ with reference to the indications on the manometer on the suction duct in proximity to the LPDP suction inlet, acting on the pneumatic pressure regulator, manually increase or decrease the pressure value of the pneumatic circuit until reaching the critical balance value, i.e. the value obtained from the graph.

To prevent continuous vibrations, the safety valve must be adjusted in such a way that it starts working at a pressure 10% higher than the working pressure.



ATTENTION

The adjustment of the mechanical safety valve must be carried out on site by the Customer, since the recycle entity depends on the LDPU speed, on the specific weight of the fluid, as well as its viscosity.



ATTENTION

The operations described herein require at least two manometers, for pressure values, installed on the suction and delivery pipes, near the LDPU openings that connect it to the plant of the Customer.

C) EXTERNAL BRIDGE MECHANICAL SAFETY VALVE AND ADJUSTMENT

The external mechanical safety valve is made up of a spring valve positioned on a pipe bridge that connects delivery and suction and can also be used as a by-pass to let all or part of the processed fluid flow back.

To adjust the external bridge safety valve act on the spring compression regulation, located on the upper part of the valve body. The system composed in this manner is one-way so if one inverts the direction of the LPDPG, it is essential to invert the positioning of the valve as well that, in any case, must always be on the delivery side.

One can choose various kinds of springs according to the working pressure. The adjustment must be carried out on site, acting manually on the special adjustment ring.

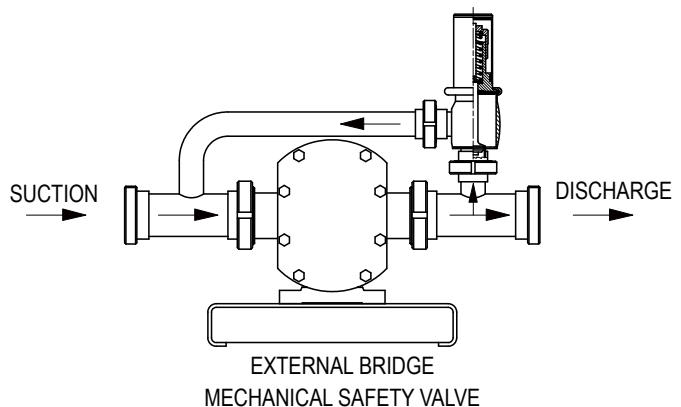

**ATTENTION**

The system composed in this manner is one-way so if one inverts the direction of the pump, it is essential to invert the positioning of the valve as well that, in any case, must always be on the delivery side.

**ATTENTION**

The adjustment of the external bridge mechanical safety valve must be carried out on site by the Customer, since the recycle entity depends on the LDPU speed, on the specific weight of the fluid, as well as its viscosity.

D) MECHANICAL SEALS FLUSHING CIRCUIT

The purpose of flushing mechanical seals is generally to cool down and lubricate the sliding faces of the mechanical seal, via forced circulation of a flushing liquid.

The flushing liquid and its distribution circuit must be provided by the Customer. **The Customer must also check, through his Technical Office, the compatibility between the flushing liquid and the process fluid, as well as the compatibility between the flushing liquid and the components of the LPDP in close contact (pumping chamber material, seals material, working temperature, etc.)**

Once this requirement has been checked and validated, the Technical Office of the Customer will see to expressly authorise the operator responsible for the installation of the LPDPG to fit the flushing circuit on the seals flushing chamber and commission it, before starting the LPDPG for the first time.

**ATTENTION**

The operator responsible for the flushing circuit must be expressly authorised by his Technical Office to connect the flushing circuit to a system that uses "flushing liquid" compatible with the process fluid.

O.M.A.C. s.r.l. is not responsible for improper use of the flushing liquid nor for damages deriving from contamination of the process fluid.

**DANGER**

The improper use of the flushing system can cause breakage of mechanical seals resulting in damage to the LPDPG and contamination of the process fluid. O.M.A.C. s.r.l. is not responsible for improper use of the flushing system.

The operator designated by the Customer must connect the flushing circuit joints to the input and output holes of the seals flushing chambers and adjust the temperature and pressure according to the type of seal fitted on the displacement pump, as described below:

- ▲ in case of single mechanical seals the flushing pressure must be about 1.5 - 2 bar and a flow-rate of 0.5-1 l/min;
- ▲ in the case of double mechanical seals the flushing pressure must be equal to the working pressure or higher by 1 bar, to ensure that the film created between the sliding faces of the seals is made up of the flushing liquid and not by the process fluid, which according to its chemical composition may crystallise and solidify after machine down time and generate, upon restarting the unit, a "sticking" phenomenon of the faces, causing their breakage.

The flushing temperature must be established according to the type of processed fluid and to the flushing utility: generally using liquid at room temperature - about 15° - 20° - is necessary to disperse the heat generated by friction of the seals faces, or vice-versa, using liquid at higher temperatures, for example 80° - 90°, can be useful for melting, removing, cleaning and lubricating the seals faces.

The dimensions of the inlet and outlet holes joints of the flushing circuit are listed in the table in section 1.3.9 in chapter 1.

Below there is an illustration of the two kinds of flushing:

flushing diagram for low pressure seals

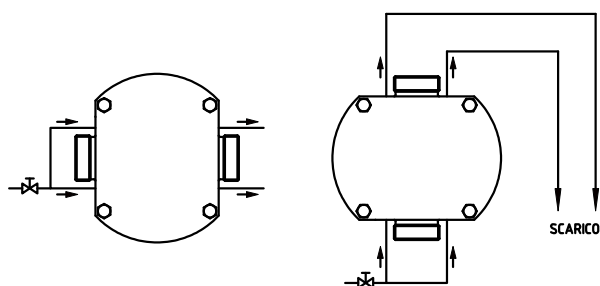

flushing diagram for double seals with circuit under pressure

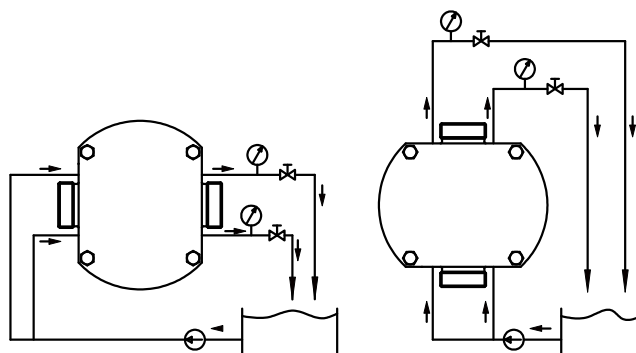
**E) ASEPTIC LIQUID CIRCUIT**

The aseptic liquid circuit (water steam), connected to the components of the LPDPG which will come into contact with the process fluid (pumping chamber, unit connection openings, sealing parts) are used to ensure the product is aseptic, during its transfer cycle performed by the LPDPG, from its suction inlet to its delivery outlet.

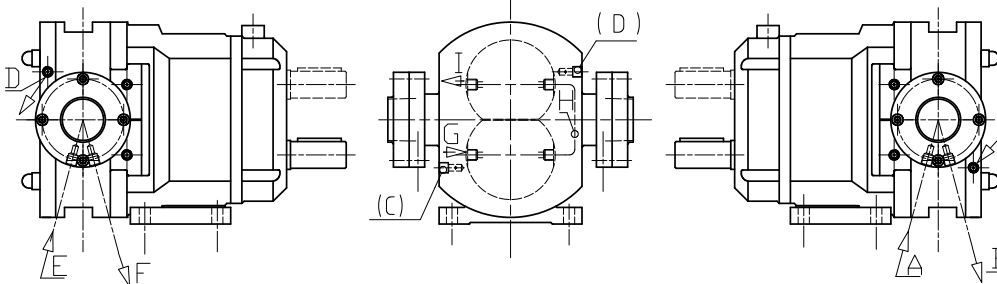

If the LPDP, part of the LPDPG, is supplied in "aseptic" version, i.e. with front cover and suction and delivery connection openings equipped with internal duct for steam barrier, the Customer must connect the water steam source and relative delivery to the joints of the

above-mentioned circuit, to make the components of the lobe displacement pump aseptic.

This necessitates the presence of a steam circuit inside the plant of the Customer.

The dimensions of the inlet and outlet holes joints of the aseptic circuit are listed in the table in section 1.3.9 in chapter 1.

F) COVER AND PUMPING CHAMBER HEATING/COOLING CIRCUIT

The heating / cooling circuit must be connected to the auxiliary circuit of the plant in which the LPDPG is located and must be commissioned by the designated operator before starting the plant concerned by the process fluid, in order to adapt (raise, if the intent is to heat or lower, if the intent is to cool down) the temperature of the components of the LPDP, affected by contact with the process fluid at the temperature of the same process fluid.

The dimensions of the inlet and outlet holes joints of the heating / cooling circuit of the cover and pumping chamber are listed in the table in section 1.3.9 in chapter 1.

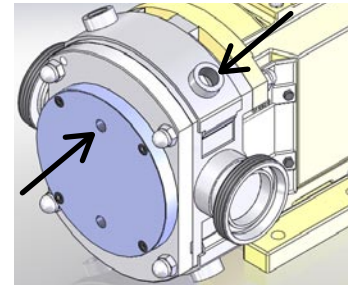

3.4 Cleaning and hygiene of the LPDPG

Listed below are the methods for cleaning the LPDPG according to its operation environment: alimentary with hygiene level 3 or chemical.



ATTENTION

The Customer must also check, through his Technical Office, the compatibility between the C.I.P. liquid and the components of the LPDPG "B series lobe displacement Pump Unit" in close contact (pumping chamber material, seals material, working temperature, etc.)

3.4.1 LDPU for alimentary use

To ensure hygiene and healthiness of the processed alimentary fluid, installation and start-up of the LPDPG requires preventive cleaning and sanitisation activities, these activities must take into account the particular features of the processed alimentary fluid, as well as reaction times defined by the manufacturer of the detergent and sanitising product used and mentioned in the technical sheet. For this reason the cleaning and sanitisation activities described in this section must be carried out in each of the following situations:

- ▲ after the installation of the LPDPG;
- ▲ after a long down time of the LPDPG;
- ▲ before every change of processed alimentary fluid;
- ▲ at the end of a work shift;
- ▲ when otherwise required by the characteristics of perishable processed alimentary fluid (short machine down times, changes of temperature, etc);
- ▲ after routine/extraordinary maintenance.

Once it has been installed in the plant of the Customer, the LPDPG becomes an integral part both of the process unit and of the scheduled cleaning system. In any case, as required by UNI EN standards for cleaning / sanitising this product, the level of hygiene of the LPDPG can be identified as LEVEL 3, so the activities described below are conducted to restore the same level of hygiene.

Generally the products used for cleaning and sanitising are of the following types:

- ▲ descaling detergents (cleaning of surfaces in contact with alimentary fluid after a long machine down time);
- ▲ degreasing detergents (external cleaning, cleaning of surfaces in contact with alimentary fluid);
- ▲ sodium hypochlorite based detergents in aqueous solution (5%) (sanitisation of surfaces in contact with alimentary fluid after a long machine down time);
- ▲ detergents with quaternary ammonium salts in aqueous solution (5%) (sanitisation of surfaces in contact with alimentary fluid after a long machine down time);
- ▲ please note that the LPDPG requires cleaning and sanitising after a long machine down time or routine/extraordinary maintenance, one must precede these activities by washing with a descaler, to be left to act according to the times indicated by the manufacturer.

Cleaning activities must be carried out by the operators in charge of running the plant in which the LPDPG is integrated, therefore they must be read, understood and carried out carefully by these operators.

Cleaning activities, if manual, must be carried out with the plant switched off and insulated from its energy sources.



ATTENTION

Cleaning activities must be carried out by the operators in charge of running the plant, therefore they must be read, understood and carried out carefully by these operators.

**ATTENTION**

The hygiene level of the LPDPG can be identified as LEVEL 3, according to UNI/EN standards, therefore the activities described below are carried out in order to restore the same hygiene level.

Cleaning and sanitising activities that concern the LPDPG are divided according to two different contexts:

- ⤴ external: DO NOT affect surfaces in contact with alimentary fluid;
- ⤴ internal: affect surfaces in contact with alimentary fluid.

Below are the descriptions of the cleaning and sanitisation methods mentioned above.

3.4.1.1 External cleaning instructions

The activities described herein must be carried out with the unit switched off and insulated from its energy sources and are intended to be performed by the operators responsible for running the plant of which the LPDPG is an integral part, therefore they must be read, understood and performed carefully by these operators.

These cleaning activities are carried out manually, using the instruments needed to enact them, provided by the Customer and indicated below:

- ⤴ pressure washer connected to waterworks under pressure;
- ⤴ NON aggressive detergent with degreasing surfactants;
- ⤴ wear the P.P.E. already provided by the Customer and Manufacturer of the plant in which the LPDPG becomes an integral part, PPE that must take into account what is indicated in the safety sheet of the detergent used.

After having put the detergent in the pressure washer and before going any further, cover the electric control panel, the electric motor and machine wiring, paying particular attention to the cables input into the shunt/connection boxes, with nylon sheets, fastened securely.

Paying attention to NOT direct the water jet onto parts covered with nylon sheets and indicated above, switch on the pressure washer and proceed with the cleaning the LPDPG, orientating the water jet under pressure only towards the external surfaces of the pump, part of the LPDPG, as well as the fixing base on which the pump is fixed.

**ATTENTION**

DO NOT direct the jet onto parts covered with the nylon sheets such as: electric control panel, electric motor and wiring in the machine. Pay utmost attention to NOT wet the cables input into the shunt/connection boxes.

If required by the manufacturer of the detergent used and if specified on the relative information sheet, rinse using cold water only.

3.4.1.2 Internal cleaning instructions

The cleaning and sanitisation activities of the surfaces in contact with alimentary products develops according to the following diagram, following the indicated frequency:

WASHING STAGES	DETERGENT AGENT	WHEN TO USE	PERIODICITY
STAGE 1	DESCALING	FOLLOWING LONG MACHINE DOWN TIME	EVERY 3 MONTHS
STAGE 2	DEGREASING	TO REMOVE RESIDUES OF PROCESS FLUID IN CONTACT WITH THE PROCESS FLUID	ALWAYS
STAGE 3	SODIUM HYPOCHLORITE BASE	AFTER STAGE 2, TO SANITISE SURFACES	ALWAYS
STAGE 4	WATER	TO ELIMINATE RESIDUES OF DETERGENT	ALWAYS
STAGE 5	STEAM	TO STERILISE THE COMPONENTS IN CONTACT WITH THE PROCESS FLUID	ALWAYS

Cleaning the surfaces in contact with the transferred process fluid articulates further into two different methods, as shown below:

- ⤴ **CIP/SIP;**
- ⤴ **manual cleaning.**

Below the two methods are explained better. - ;

3.4.1.2.1 Internal cleaning: CIP (Cleaning In Place)/SIP (Sterilising In Place)

As well known, the CIP/SIP is a cleaning method of the entire plant that does NOT require the disassembly of parts and/or accessories inside the same plant. The CIP/SIP is therefore a cleaning and sanitisation activity of the plant of which the LDPU is an integral part and therefore in turn affected by it.

**ATTENTION**

Before carrying out CIP/SIP one must perform each of the operations described below.

If the LPDPG has been supplied with one or more accessories listed in section 3.3.3. of this OMM, before starting CIP/SIP, check the following:

- ⤴ adjust the pressure of the safety valves (re. section 3.3.3 letters a,b,c) at a pressure value below the maximum pressure of the same CIP/SIP, thus ensuring opening of the valve when washing the plant;
- ⤴ ensure that the auxiliary units (flushing unit, cover heating and aseptic circuit), if present, are connected to the pump and work;
- ⤴ if the customer envisions the LPDPG to actively participate in the CIP/SIP, activate operation of the same LPDPG.

On the basis of the indications given by the plant manufacturer, activate the CIP/SIP.

The duration of CIP/SIP depends on the type of process fluids treated. In order to ensure sanitisation of the LDPU, O.M.A.C. s.r.l. recommends the CIP/SIP to last at least 1 hour.



ATTENTION

At the end of the CIP/SIP, but before restarting the plant, the safety valves must be re-set at the working pressure value, this activity must follow what is indicated in section 3.3.3 of this OMM.

3.4.1.2.2 Internal cleaning: manual cleaning

Manual cleaning activities must be carried out with the plant switched off and insulated from its energy sources; in addition the operator must wear P.P.E. as indicated in chapter 1, section 9.

Manual cleaning activities entail:

- a) disassembly of mechanical elements;
- b) treated alimentary process fluids removal/extraction operations;
- c) washing and sanitisation activities;
- d) rinsing;
- e) sterilisation;
- f) reassembly of the previously removed mechanical elements.

Wear the P.P.E. as per Chapter 1, Section 9, paying attention to identify, on the basis of the thermal features of the treated process fluids, the gloves to wear;



ATTENTION

Cleaning activities must be carried out by the operators in charge of running the plant, therefore they must be read, understood and carried out carefully by these operators.



DANGER

Cleaning and sanitisation activities must be carried out with the plant switched off and insulated from its energy sources: electrical, pneumatic, hydraulic. The operator in charge of this activity is obliged to wear the P.P.E. indicated in chapter 1, section 9, in order to ensure their safety.

a) The disassembly activities refer to the following mechanical elements:

- ⤴ front cover;
- ⤴ rotor blocking nuts;
- ⤴ rotors;
- ⤴ gaskets;
- ⤴ any optional features (mechanical or pneumatic safety valve).

These elements must be disassembled following the indications contained in chapter 5, section 5.8, 5.9, 5.10 of this OMM.



ATTENTION

During disassembly and assembly operations of the components listed under letter a), strictly follow the indications in sections 5.8, 5.9, 5.10.

b) The alimentary process fluids removal activities consist in manually removing most of the fluid present and seeing to its disposal.

c) Washing and sanitisation activities concern the previously disassembled single components, as well as the pumping chamber. Using a water and degreasing detergent solution, wash the single components and the pumping chamber, paying particular attention to the seals area and shafts threaded area.

d) Wash with plenty of aqueous solution until the visible process alimentary fluid is completely removed.

Once the alimentary process fluid has been removed from the contact surfaces, sanitise all the components that come into contact with the fluid. To do this:

- ⤴ prepare aqueous solution of sodium hypochlorite (5%);
- ⤴ sanitise all surfaces in contact with the alimentary process fluid carrying out the operation for at least 15 minutes



ATTENTION

Sanitise all surfaces in contact with the alimentary product proceeding for at least 15 minutes

- ⤴ with cold running water, rinse all the previously sanitised surfaces, making sure all traces of sanitiser are removed.

e) Sterilise the previously sanitised surfaces with water steam.

f) Reassemble the previously removed mechanical elements following the indications contained in Chapter 5, section 5.8, 5.9, 5.10 of this OMM.

After having assembled the clean and sanitised pump components, remove the protective sheets, placed on the electric panel, electric motor and cable shunt/connection boxes and subsequently connect to the energy sources, disconnected before starting manual cleaning.

3.4.2 LPDPG for chemical use

To ensure cleaning the process chemical fluid, LPDPG installation and starting requires prior cleaning activity.

The cleaning activities described herein must be carried out in each of the following situations:

- ⤴ after the installation of the LPDPG;
- ⤴ after a long down time of the LPDPG;

- ⤴ before every change of processed chemical fluid;
- ⤴ at the end of a work shift;
- ⤴ when otherwise required by the characteristics of perishable processed chemical fluid (short machine down times, changes in temperature, etc);
- ⤴ after routine/extraordinary maintenance.

Once it has been installed in the plant of the Customer, the LPDPG becomes an integral part both of the process unit and of the scheduled cleaning system.

Generally the products used for cleaning are of the following types:

- ⤴ descaling detergents (cleaning of surfaces in contact with alimentary fluid after a long machine down time);
- ⤴ degreasing detergents (external cleaning, cleaning of surfaces in contact with chemical fluid);
- ⤴ sodium hypochlorite based detergents in aqueous solution (5%) (sanitisation of surfaces in contact with chemical fluid after a long machine down time);
- ⤴ detergents with quaternary ammonium salts in aqueous solution (5%) (sanitisation of surfaces in contact with chemical fluid after a long machine down time);
- ⤴ please note that the LPDPG requires cleaning and sanitising after a long machine down time or routine/extraordinary maintenance, one must precede these activities by washing with a descaler, to be left to act according to the times indicated by the manufacturer.

Cleaning activities must be carried out by the operators in charge of running the plant in which the LPDPG is integrated, therefore they must be read, understood and carried out carefully by these operators.

Cleaning activities, if manual, must be carried out with the plant switched off and insulated from its energy sources.



ATTENTION

Cleaning activities must be carried out by the operators in charge of running the plant, therefore they must be read, understood and carried out carefully by these operators.

The cleaning activities that concern the LPDPG are divided according to two different contexts:

- ⤴ external: DO NOT affect surfaces in contact with chemical fluid;
- ⤴ internal: affect surfaces in contact with chemical fluid.

Below are the descriptions of the cleaning methods mentioned above.

3.4.2.1 External cleaning instructions

The activities described herein must be carried out with the unit switched off and insulated from its energy sources and are intended to be performed by the operators responsible for running the plant of which the LPDPG is an integral part, therefore they must be read, understood and performed carefully by these operators.

These cleaning activities are carried out manually, using the instruments needed to enact them, provided by the Customer and indicated below:

- ⤴ pressure washer connected to waterworks under pressure;
- ⤴ NON aggressive detergent with degreasing surfactants;
- ⤴ wear the P.P.E. already provided by the Customer and Manufacturer of the plant in which the LPDPG becomes an integral part, PPE that must take into account what is indicated in the safety sheet of the detergent used.

After having put the detergent in the pressure washer and before going any further, cover the electric control panel, the electric motor and machine wiring, paying particular attention to the cables input into the shunt/connection boxes, with nylon sheets, fastened securely.

Paying attention to NOT direct the water jet onto parts covered with nylon sheets and indicated above, switch on the pressure washer and proceed with the cleaning the LPDPG, orientating the water jet under pressure only towards the external surfaces of the pump, part of the LPDPG, as well as the fixing base on which the pump is fixed.



ATTENTION

DO NOT direct the jet onto parts covered with the nylon sheets such as: electric control panel, electric motor and wiring in the machine.

Pay utmost attention to NOT wet the cables input into the shunt/connection boxes.

3.4.2.2 Internal cleaning instructions

The cleaning and sanitisation activities of the surfaces in contact with alimentary products develops according to the following diagram, following the indicated frequency:

WASHING STAGES	DETERGENT AGENT	WHEN TO USE	PERIODICITY
STAGE 1	DESCALING	FOLLOWING LONG MACHINE DOWN TIME	EVERY 3 MONTHS
STAGE 2	DEGREASING	TO REMOVE RESIDUES OF PROCESS FLUID IN CONTACT WITH THE PROCESS FLUID	ALWAYS
STAGE 3	SODIUM HYPOCHLORITE BASE	AFTER STAGE 2, TO SANITISE SURFACES	ALWAYS
STAGE 4	WATER	TO ELIMINATE RESIDUES OF DETERGENT	ALWAYS

Cleaning the surfaces in contact with the transferred process fluid articulates further into two different methods, as shown below:

- ▲ **CIP;**
- ▲ **manual cleaning.**

Below the two methods are explained better.

3.4.2.2.1 Internal cleaning: CIP (Cleaning In Place)

As well known, the CIP/SIP is a cleaning method of the entire plant that does NOT require the disassembly of parts and/or accessories inside the same plant. The CIP is therefore a cleaning activity of the plant of which the LPDPG is an integral part and therefore in turn affected by it.



ATTENTION

Before carrying out CIP one must perform each of the operations described below.

If the LPDPG has been supplied with one or more accessories listed in section 3.3.3 of this OMM, before starting CIP, check the following:

- ▲ adjust the pressure of the safety valves (re. section 3.3.3 letters a,b,c) at a pressure value below the maximum pressure of the same CIP, thus ensuring opening of the valve when washing the plant;
- ▲ ensure that the auxiliary units (flushing unit, cover heating and aseptic circuit), if present, are connected to the pump and work;
- ▲ if the customer envisions the LPDPG to actively participate in the CIP, activate operation of the same LPDPG.

On the basis of the indications given by the plant manufacturer, activate the CIP.

The duration of CIP depends on the type of process fluids treated. In order to ensure sanitisation of the LPDPG, O.M.A.C. s.r.l. recommends the CIP to last at least 1 hour.



ATTENTION

At the end of the CIP, but before restarting the plant, the safety valves must be re-set at the working pressure value, this activity must follow what is indicated in section 3.3.3 of this OMM.

3.4.2.2.2 Internal cleaning: manual cleaning

Manual cleaning activities must be carried out with the plant switched off and insulated from its energy sources; in addition the operator must wear P.P.E. as indicated in chapter 1, section 9. Manual cleaning activities entail:

- a) disassembly of mechanical elements;
- b) chemical process fluid removal/extraction operations;
- c) washing and sanitisation activities;
- d) rinsing;
- e) reassembly of the previously removed mechanical elements.

Wear the P.P.E. as per Section 1.9 of Chapter 1, paying attention to identify, on the basis of the thermal features of the process fluids, the gloves to wear;



ATTENTION

Cleaning activities must be carried out by the operators in charge of running the plant, therefore they must be read, understood and carried out carefully by these operators.



DANGER

Manual cleaning activities must be carried out with the plant switched off and insulated from its energy sources: electrical, pneumatic, hydraulic. The operator in charge of this activity is obliged to wear the P.P.E. indicated in chapter 1, section 9, in order to ensure their safety.

a) The disassembly activities refer to the following mechanical elements:

- ▲ front cover;
- ▲ rotor blocking nuts;
- ▲ rotors;
- ▲ gaskets;
- ▲ any optional features (mechanical or pneumatic safety valve).

These elements must be disassembled following the indications contained in chapter 5, section 5.8, 5.9, 5.10 of this OMM.



ATTENTION

During disassembly and assembly operations of the components listed under letter a), strictly follow the indications in sections 5.8, 5.9, 5.10.

- b) The chemical process fluids removal activities consist in manually removing most of the fluid present and seeing to its disposal.
- c) Washing and sanitisation activities concern the previously disassembled single components, as well as the pumping chamber. Using a water and degreasing detergent solution, wash the single components and the pumping chamber, paying particular attention to the seals area and shafts threaded area.
- d) Wash with plenty of aqueous solution until the visible process chemical fluid is completely removed.

Once the chemical process fluid has been removed from the contact surfaces, clean all the components that come into contact with the fluid. To do this:

- ⤴ prepare aqueous solution of sodium hypochlorite (5%);
- ⤴ clean all surfaces in contact with the chemical process fluid carrying out the operation for at least 15 minutes;



ATTENTION

Sanitise all surfaces in contact with the chemical product proceeding for at least 15 minutes.

- ⤴ with cold running water, rinse all the previously cleaned surfaces, making sure all traces of sanitiser are removed.

e) Reassemble the previously removed mechanical elements following the indications contained in Chapter 5, section 5.8, 5.9, 5.10 of this OMM. After having assembled the clean pump components, remove the protective sheets, placed on the electric panel, electric motor and cable shunt/connection boxes and subsequently connect to the energy sources, disconnected before starting manual cleaning.

3.5 Connection to energy sources

Below there are the procedures for connecting the LPDPG to the energy sources, needed for its proper operation.

3.5.1 Connection to the electrical system

Connection to the electrical mains must be carried out by the operator responsible for the assembly/installation activities, in compliance with the strictest technical standards, the connection must be carried out after the hydraulic connection. This personnel must have full knowledge of the rules for use and operation of electrical equipment supplied with the LPDPG.

The Customer must organise the plant layout so as to provide:

- ⤴ a manual supply sectioning device,
- ⤴ over-current and overload protection,
- ⤴ devices that prevent spontaneous restarting.
- ⤴ Before carrying out the connection one must ensure that:
 - ⤴ the frequency and voltage of the Customer plant corresponds to the data carried in the "technical sheet" of the LPDPG;
 - ⤴ The material used for the electrical connection has an IP degree suitable for the environment in which it is installed, in order to prevent the conductors from overheating.

The connection of cables to the terminal board can be carried out both in triangle or star, complying with the data carried on the motor nameplate according to the mains voltage.

The connection of electric wiring can take place as follows:

- 1) LPDPG with electric panel; 2) LPDPG without electric panel;

In particular, in case 1), in presence of the electric panel, the operator must carry out the following operations:

- ⤴ section the electric mains in order to insulate the sockets from the industrial electricity supply;
- ⤴ connect the plug;
- ⤴ power the electricity sockets;

this way even the LPDPG electric control panel is powered.



ATTENTION

Operate with caution: the LPDPG and the control actuators are powered electrically.

In case 2), in absence of the electric panel, the operator must see to power the electric motor on the basis of the indication contained in the electric motor Use and Maintenance Manual (OMM available in electronic version on the Internet websites of the relative manufacturers).

One must also provide earthing for the motor, using the jack provided on the motor and an adequate section conductor: the connection must be carried out with a NO7Vk type 35 mm² section stranded wire with yellow-green insulation and crimped wire heads.



ATTENTION

Before carrying out any operation, check that the features of the distribution network (voltage and frequency) correspond to the data on the motor plate or electric panel.



ATTENTION

O.M.A.C. s.r.l. is NOT responsible for damages caused by incorrect installation of the electric energy supply, in case of failure to comply with the technical standards in force.

3.5.2 Connection to the hydraulic system

Before going further one must check compliance with the indications of section 3.3.2 of this chapter.

If the indications above have been observed, one can proceed with the following activities:

- a) connection of mechanical seals flushing;
- b) connection of pumping chamber cover heating/cooling;
- c) connection of pumping body heating/cooling.



ATTENTION

It is essential, as indicated in section 3.3.1, before carrying out the hydraulic connections, to wash the plant - in order to clean the pump -, and the hydraulic connection lines, from dirt residues such as dust, sand, process scraps, etc.

a) with reference to the drawing to the side and the dimensions of the threaded joints, shown in the table in section 1.3.9, identify the flushing connection points on the LPDPG as well as the types of fittings to use.

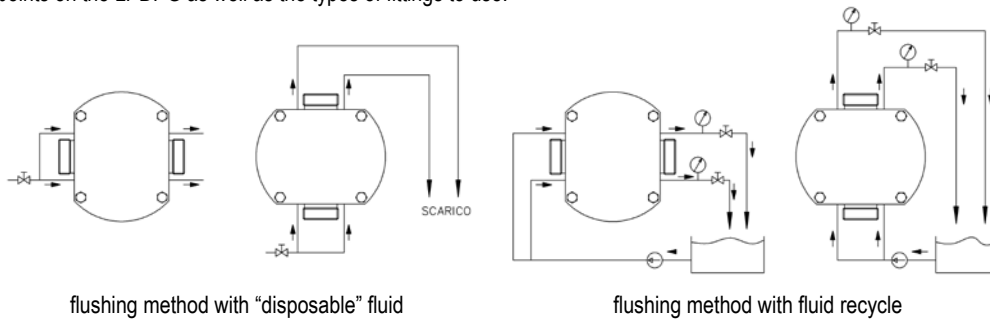

b) connection of pumping chamber cover heating/cooling;

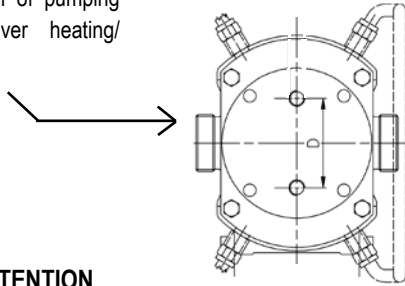

c) connection of pumping body heating/cooling;

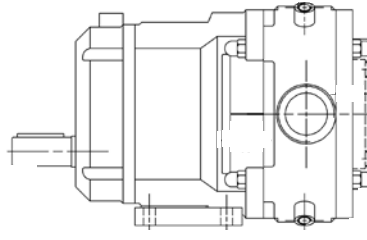

ATTENTION

The Customer, on the basis of the table in section 1.3.9 must identify the proper kind of fittings to be used to connect the hydraulic unit. Any errors can generate leaks of flushing/cooling/heating fluid not attributable to O.M.A.C. s.r.l.

To start assembly activities, the pipes used to compose the flushing/cooling/heating circuit must have fittings free to rotate at their ends in order to screw onto the flushing chamber and cooling/heating chambers.



ATTENTION

Check that the ends of the fittings are free to rotate. If they are fixed to the pipe it will no longer be possible to screw them on and one must provide new pipes of the same kind.

On the basis of the diagrams above, proceed with assembly, taking care to tighten the fittings.

Switch on the flushing unit and the cooling / heating unit that belong to the Customer in order to check there are no leaks of fluid, i.e. check the operations above have been carried out properly.



ATTENTION

The Customer must ensure that the flushing unit is always started before starting the LPDPG.

In case of brief or extended machine down times during the production period, in which the process fluid remains in contact with the internal parts of the pumping body (e.g. transfers of vinyl glue in industrial use), the flushing unit must remain in constant operation, to not jeopardize the operation of the pumping body sealing parts.

If one should find leaks, switch off the flushing unit and repeat the operations described above.

3.5.3 Connection to the pneumatic system

Connection to the pneumatic system assumes that the Customer provides connection to a pneumatic lubricated compressed air unit: the capacity and pressure (bar) values of this unit are indicated in the attached technical sheet.



ATTENTION

The technical sheet carries the pressure and capacity values the LPDPG needs to operate properly.



ATTENTION

Before going any further, ensure to comply with the indications of section 3.3.1 of this chapter.

In order to connect the LPDPG to the pneumatic distribution network in safety conditions, observe and perform the following operations in sequence:

- ▲ close the valve the LPDPG will be connected to;
- ▲ connect the light blue pipes with threaded fittings to the compressed air distribution unit;
- ▲ close the connection between the pipe and unit securely;
- ▲ connect the light blue pipes with the threaded fittings to the LPDPG;
- ▲ close the connection between the pipe and the LPDPG securely;
- ▲ open the general valve and check the connection has been carried out properly.

3.6 Use of lubricants

The LPDPG is delivered to the Customer complete with lubricant oil as per section 1.3.12. This oil is contained in the bearings box and is essential for the lubrication of bearings and motion transmission gears. Please note that the LPDPG has other mechanical elements that during maintenance require lubrication. In chapter 5 there is further information regarding these operations.

3.7 Installation and pre-start check: operation test

After installation and connection to the energy sources, but before starting production, one must check the rotors rotate properly inside the pumping body, compared to the flow direction of the fluid to be handled. To do this one must:

- ⤴ check all earthing connections of the LPDPG have been carried out;
- ⤴ power the LPDPG electrically;
- ⤴ open the suction valve of the Customer plant;
- ⤴ open the delivery valve of the Customer plant;
- ⤴ wait for a few seconds (about 15 seconds) so that the fluid fills the pumping chamber;
- ⤴ move the selector from position 0, off, to position 1, on (the on warning light will light up);
- ⤴ press the START button;
- ⤴ with the LPDPG on, check that on the manometer on the delivery pipe there is pressure inside the same pipe;
- ⤴ stop the LPDPG by pressing the STOP button on the electric panel supplied with the machine or in the plant of the Customer.

CHAPTER 4: USE

The LPDPG is intended to be used by operators in charge of running it; therefore:

- ✦ the operators in charge of using the LPDPG must have good familiarity with this type of equipment and possess recognised technical skills acquired in at least three years of similar activities;
- ✦ the operator in charge of running the unit is directly and formally named by the Customer company management;
- ✦ the instruction described in this chapter and relative to the LPDPG must be read, understood and carried out carefully by these operators in charge.



ATTENTION

Knowledge of the following instructions and the experience of the operator in charge of running the plant of the customer are essential in order to limit and reduce the risks associated with using the same production line.

4.1 Intended use

The BA BB BF Series Lobe Positive Displacement Pump Group, manufactured and marketed by O.M.A.C. s.r.l., which in this documentation will be indicated with the abbreviation LPDPG, has been designed and made to be assembled in industrial plants owned by third parties, to transfer volumes of fluids, compatible with the materials used during the construction of this machine: section 1.4.1 lists the recommended operational features of the LPDPG, depending on the processed fluid.

The LPDPG requires compliance with all technical indications in this operation and maintenance manual, which in this documentation will be indicated with the abbreviation OMM, for its proper installation.

In general, the processed fluids must meet the following specifications:

Fluid properties and range of use:

- 1) TEMPERATURE: from **-35°C to +180°C**
- 2) VISCOSITY: Maximum **200'000cPs** with forced feeding
- 3) HARD PARTICLE SIZE: Maximum **80% of clearance between rotors** (see sect.1.3.4)

The LPDPG has been designed and made for two types of use:

- ✦ alimentary use;
- ✦ chemical use.



WARNING

The LPDPG, for alimentary use, has been made to ensure a hygienic standard equal to **LEVEL 3**, on the basis of **UNI EN 13951**.

The LPDPG for alimentary use and for chemical use has been designed to transfer volumes of fluids without altering the organoleptic properties nor the physical properties.



WARNING

During its normal use, the LPDPG for alimentary use and chemical use does not alter the organoleptic characteristics or the physical characteristics of the processed fluid.

Every LPDPG comes with a technical sheet indicating the operational features in relation to the processed fluid that must be handled (name of the fluid, viscosity range, capacity range, speed range, temperature range), as declared at the time of purchase by the Customer.

Section 1.3 shows a facsimile of the LPDPG technical sheet.

Every modification to what is indicated in the specific technical sheet or variation of the machine operating parameters must be authorised in writing by O.M.A.C. s.r.l.; the absence of such authorisation is deemed "improper use" and will void any warranty or liability under way between Manufacturer and Customer.



DANGER

Any use of the LPDPG in conditions other than those indicated in "Fluid properties and range of use" and in conditions other than those indicated in the machine technical sheet is forbidden, without explicit written authorisation, issued by O.M.A.C. s.r.l.

The LPDPG for alimentary use and for chemical use has NOT been designed nor built to handle pharmaceutical, explosive, etc. fluids, and in general fluids that do not comply with the indications of the specific technical sheet.

In addition, the LPDPG for alimentary use and chemical use has NOT been designed nor built to handle what is indicated in Regulation (EC) No. 1005/2009 of the European Parliament and the Council of 16 September, 2009, on substances that deplete the ozone layer.



ATTENTION

It is forbidden to use the LPDPG for alimentary use and chemical use to transfer the substances listed in Annex I of Regulation No. 1005/2009.

The pumping part of the LPDP is made up of the pump body, in which two rotors are housed (sect. 1.3.5 lists the types of rotors used), which rotate synchronised in the opposite direction to each other.

The rotorcase receives the process fluid from the suction inlet, originating from the plant of the Customer. During the operation of the LPDP, the cavities between the lobes of the rotors are filled with fluid and the counter-rotation of the rotors transfers the fluid to the delivery outlet of the pump body, channelling it in the plant where the LPDPG is installed.

4.2 Controls

The LDPU can be equipped, upon request of the Customer and as an additional optional feature, with an electric control panel, where the “control actuators” are positioned for its operation.

All control, signalling and adjustment devices are marked with symbols and codes that enable to quickly understand their functions, as described below. The same devices are marked with different colours: each colour has a specific meaning.

COLOURS FOR LUMINOUS INDICATORS	MEANING
RED	DANGER / ALARM
YELLOW	ATTENTION
GREEN	SICUREZZA
WHITE	NEUTRAL
BLUE	ACCORDING TO NEEDS

CONTROLS	MEANING
RED	EMERGENCY ACTION (STOP / DISABLING)
YELLOW	INTERVAL
GREEN	START / ENABLING

Below there is the illustration of the basic composition of an electric panel:

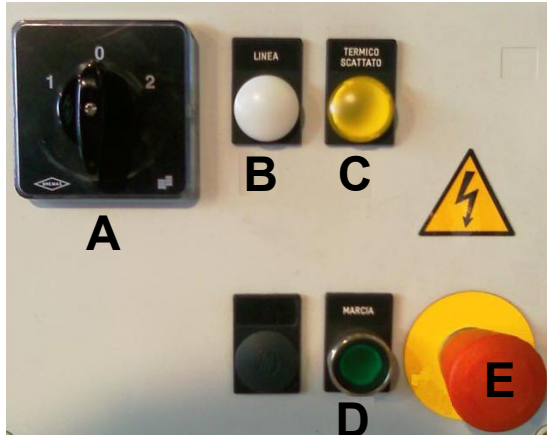

In the figure to the side one can identify:

- A** MAIN SWITCH
- B** LINE WARNING LIGHT
- C** CIRCUIT BREAKER TRIPPED WARNING LIGHT
- D** ON BUTTON + ON WARNING LIGHT
- E** EMERGENCY STOP BUTTON

The **main switch**, marked with letter **A**, is for powering or insulating the machine electric unit, position “**0**” indicates the absence of voltage, position “**1**” indicates the presence of voltage with the pump that operates with a certain rotation direction, position “**2**” indicates the presence of voltage with the pump that operates with the rotation direction opposite to that of position “**1**”.

When main switch A is in position “1” or in position “2”, one cannot open the electric panel because in this position opening is inhibited by an interblock. One can open the control panel only by putting the switch in “0” position.

The **indicator light**, marked with letter **B**, when on indicated that the electric panel is “under voltage”. this condition occurs only if button A is in position “1” or in position “2”.

The **emergency stop button**, marked with letter E, has the function to block the operation of the LPDPG with immediate effect, in emergency conditions.

However it can be used to stop operation of the LPDPG even in case of normal functioning, when switch A is not present.

NOTE

The particular “mushroom” shape of the button enables easy and quick intervention of the operator, in addition a mechanical retention blocks it in pressed position.

Only after having released the button can one restore the normal operation conditions of the LPDPG. One can rearm the button by slightly rotating the knob anti-clockwise.

The **on button**, marked with letter **D**, is for starting the LPDPG in normal and continuous operation mode. The on and off conditions are signalled by the green light incorporated in the button: when the warning light is on it indicates that the LPDPG is on, when it is switched off it indicates that it is off.

The **indicator light**, marked with letter **C**, which indicates “CIRCUIT BREAKER TRIPPED”, lights up for an operation anomaly of the LPDPG, the electric motor is in overload. To reset normal operation conditions one must restore the “circuit breaker” as specified in the use and maintenance instructions of the electrical supply.

The electric control panel can be equipped with an **inverter**, as an additional optional feature: it can be identified, in the figure below, with letter **G**, which indicates the operation warning light, and with letter **F**, which indicates **speed adjustment potentiometer**, which is needed to set the electric power supply voltage manually.

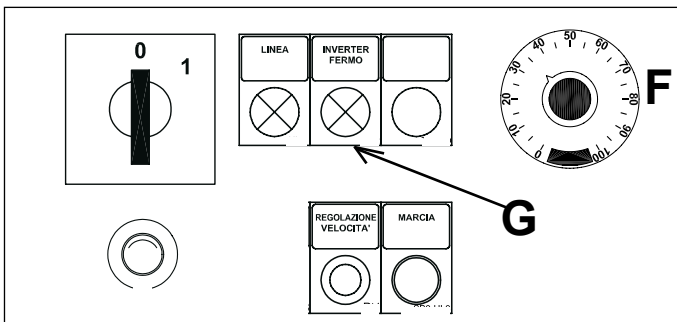

An inverter is in fact an electronic device able to vary the rotation speed of electric motors, which is directly associated with the supply voltage frequency.

Section 4.2.1.1 shows a simple mathematical formula for calculating the power supply frequency, knowing the number of output revolutions of the control unit.

4.3 LDPU volumetric capacity adjustment methods

On the basis of the production needs of the Customer, one can adjust the power supplied by the LPDPG. The adjustment of the volumetric capacity of the LPDPG can be carried out in two ways:

- ⤴ acting on the inverter adjustment, if the LPDPG is equipped with an inverter;
- ⤴ acting on the speed controller hand-wheel adjustment, if the LPDPG is equipped with a mechanical speed controller.

4.3.1 Adjustment of the volumetric capacity with the inverter

This operation, i.e. the variation of the electric motor speed via inverter, must be carried out by the operator in charge of running the plant: he must rotate the speed adjustment potentiometer knob on the electric panel, setting it on the desired frequency value, expressed in Hz.

The result of the frequency adjustment, with the potentiometer, translates in a speed variation of the electric motor revolutions and consequently in a capacity variation of the LPDPG.

The operator must read the consequent volumetric capacity variation on the meter placed on the delivery piping near the LPDPG (see stage 2 section 3.3.3).

Frequency calculation.

It is assumed one has an electric motor that supplies a current number of output revolutions, $N_{current}$ at the national electric network frequency, equal to 50 [Hz] and that we will indicate more in general with $F_{current}$. Assuming one wants to obtain a different number of output revolutions N_{new} the frequency with which the inverter must be set, f_{new} will be equal to: $f_{new} = (F_{current} * N_{new}) / N_{current}$

4.3.2 Adjustment of volumetric capacity via mechanical speed controller

This operation, i.e. the speed variation of the speed controller, must be carried out by the operator in charge of running the plant:

he must act on the mechanical speed controller hand-wheel, only after having started the LPDPG.

This operation, i.e. the speed variation of the speed controller, must be carried out by the operator in charge of running the plant:

he must act on the mechanical speed controller hand-wheel, only after having started the LDPU.



WARNING

Adjust the mechanical speed controller hand-wheel, only after having started the LPDPG. The adjustment of the speed controller must not be carried out with the machine off as it can cause the breakage and malfunctioning of the speed controller.

Before adjusting the hand-wheel, read the value the speed controller is set on, in the hand-wheel panel. The hand-wheel panel is shown in figure A. Below, in the table placed to the side as an example, one can obtain the value of the LPDPG revolutions.

For example, if we are in presence of a size "10" speed controller and the hand-wheel (figure A) has the arrow on 5, simply trace a vertical line, starting from the column corresponding to the "10" size, until 5, indicated by the hand-wheel, to then proceed horizontally, towards the left until reading the corresponding number of revolutions at which the speed controller operates, i.e. 450 RPM.

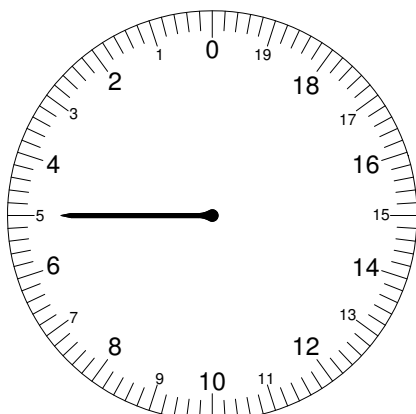

figure A

CORRESPONDING OUTPUT REVOLUTIONS [RPM] OF THE SPEED CONTROLLER	QUANTITIES REFERRED TO MOTOVARIO/SPAGGIARI SPEED CONTROLLERS					
	03	05	10	20	30-50	
1000		12	15	17	21.5	25
		11			21	
950			14	16	20	24
900	9	10		15	19	23
850			13	14	18	22
800	8	9	12	13	17	21
			11	12	17	19
750	7	8		11	16	18
700			10	11	15	17
650	6	7	9	10	14	16
600		6	8	9	13	15
550	5		7	8	12	14
		5		7	11	13
500	4	4	6	6	10	12
			5	5	9	11
450	3	3	4	4	8	10
			3	3	7	9
400	2	2	3	3	6	8
			2	2	5	7
350	1	1	2	2	4	6
			1	1	3	5
300	0	0	1	1	2	4
			0	0	1	3
250					0	2
						1
190						0

CORRESPONDING OUTPUT REVOLUTIONS [RPM] OF THE SPEED CONTROLLER

QUANTITIES REFERRED TO MOTOVARIO/SPAGGIARI SPEED CONTROLLERS

4.4 Work cycle description

The LPDPG, whose functional element is the LPDP, is equipped with a control unit that, depending on the version, can be fitted with a speed controller, a gear motor, an electric motor, a pneumatic motor or a hydraulic motor, with or without electric panel.

The capacity adjustment is achieved by increasing or decreasing the number of revolutions of the LPDP, intervening directly on the revolutions output of the motor mentioned above or acting on the actuators on the control panel (inverter), if fitted.

The LPDPG is reversible: full performance can be achieved in both rotation directions of the pump rotors (section 1.3.5 lists the types of rotors used).

The pumping action of the LPDP is achieved thanks to the counter-rotation of two rotors (letter "C" indicated in the figure in section 1.2, indicating one of the two rotors), housed inside the pumping chamber (letter "U" indicated in the figure in section 1.2 or see figure below). The rotors are assembled on rotating shafts supported by bearings (letters "G" and "H" shown in the figure in section 1.2), which are housed in the external gearbox (letter "S" shown in the figure in section 1.2). Via a couple of sprocket wheels (letters "N" and "P" indicated in the figure in section 1.2) one transfers motion from a drive shaft (letter "M" indicated in the figure in section 1.2) to a driven shaft (letter "R" indicated in the figure in section 1.2). The synchronism of the rotors is such that they rotate without coming into contact with each other: in this conditions "the rotors are in phase".

When the lobes of the rotors move away from each other, the volume between them increases, creating a decrease in pressure near the suction outlet: this enables a certain volume of fluid to enter (value of fluid transported identified in the table in section 1.3.1, in the "theoretical capacity" column, depending on the pump model size) into the pumping body. The fluid is transported along the internal of the pumping chamber, from the suction inlet to the delivery outlet of the pump body. When the volume of fluid, trapped between the lobes and the external perimeter of the pumping chamber, reaches in proximity of the delivery outlet, the counter-rotation of the two rotors creates a sudden decrease of available volume and a consequent increase in pressure that pushes the fluid out of the pumping body, by channelling it into the plant where the LPDPG is installed.

4.5 Cycle start instructions

The start of the LPDPG work cycle is supervised and activated by the operator in charge of running the plant, after having carried out the following preliminary checks.

4.5.1 Preliminary operations: check list

Before commissioning the LPDPG check the following:

- ✦ if the LPDPG has suffered damages, contact the O.M.A.C. s.r.l. Technical Office immediately as described in chapter 2;
- ✦ make sure that all the bolted connections are tightened properly and that the installation of the LPDPG has been carried out properly in accordance with the requirements of this use and maintenance manual;
- ✦ ensure continuity of the equipotential protection circuit and that it is connected, as per section 3.5.1.1 of this use and maintenance manual;
- ✦ ensure that all hydraulic connections, where required by the configuration of the LPDPG, are carried out properly, as described in chapter 3;
- ✦ make sure, as a preventive measure, that there is lubricant oil, visible via the oil level cap placed on the side of the pump gear box, part of the LPDPG: please bear in mind that all pumps fitted in the LPDPG are already supplied with the proper amount of lubricant oil.



DANGER

Incorrect lubrication or lubrication with lubricant products incompatible with the materials used in the construction and completion of the LPDPG can lead to premature wear or breakage of the sealing elements or other parts in contact with the process fluid.



ATTENTION

O.M.A.C. s.r.l. is not liable for any damage caused by improper use of lubricants incompatible with the materials used in the construction and completion of LPDPG or with the process fluid:

- ✦ ensure that the power supply voltage of the LPDPG is that required as shown on the electric motor data plate or electric panel; it is reminded that the electric connection must be carried out by skilled personnel and compliant with the electric motor data plate, both for the connection of the terminal board and for the thermal calibration in accordance with the maximum admitted absorption;
- ✦ ensure that the pipes have been washed with clean water, to remove foreign bodies, cinders, dust or scraps from processes carried out on the plant;
- ✦ with reference to chapter 3 ensure that a CIP/SIP cleaning and/or sanitisation cycle has been carried out, as per section 3.4;
- ✦ if there is a mechanical safety valve on the front cover or a bridge one on the external cover of the LPDPG, check that the spring has been adjusted, as indicated in section 3.3.3;
- ✦ if there is a pneumatic safety valve on the front cover of the LPDPG, check that the auxiliary pneumatic unit pressure has been adjusted, as indicated in section 3.3.3;
- ✦ make sure that all gates in suction and delivery are completely open, in order to ensure the suction pipes are full of process fluid;



ATTENTION

The LPDPG must not be used to process fluids other than that / those for which it has been selected and sold, with reference to the intended use. If in doubt, contact the O.M.A.C. s.r.l. Technical Office. Fluids incompatible with the materials used in the construction and completion of the LPDPG can damage the same Unit, other parts of the unit and cause injuries and damages to the operators in charge of running the plant.

4.5.2 First start-up



ATTENTION

The BA BB BF series lobe displacement pump part of the LPDPG can also operate when empty because the moving parts are not in contact with each other, except for the sliding faces of the seals that, especially at high speeds, tend to overheat. For this reason, it is recommended to never let the B Series lobe displacement pump operate dry for long periods so not to cause premature wear of the sealing parts.

The allowed dry operation period depends on the rotation speed and materials of the sliding faces of the seals but, in any case, it is recommended not to exceed 5-10 minutes for soft materials and 10-15 seconds for hard carbides.

- ⤴ start the LPDPG possibly on reduced speed to then increase up to working speed, checking any anomalies (pump over-pressure, piping leaks, cavitation, vibration, etc.);
- ⤴ if the working speed is very high it is normal for the temperature of the pump gear box to reach 50°C - 60°C, especially in the first hours of operation;

4.6 Stopping instructions

When the LPDPG stops one must intervene on the electric control panel, present on the machine or on the plant of the Customer, and intervene on:

- ⤴ emergency stop, if a situation of danger is occurring;
- ⤴ general selector, for a machine stop.

Once one of the two buttons has been pressed, one must:

- ⤴ disconnect power and block the power device so that the LPDPG cannot be operated;
- ⤴ close the valves placed on the suction and discharge side;
- ⤴ de-pressurise, if present on the LPDPG, the pneumatic safety valve on the front cover;
- ⤴ empty and de-pressurise the pump and suction and delivery piping system connected to the LPDPG;



DANGER

If the process fluid is very hot, or in any case above room temperature, one must let the LPDPG cool down, with particular reference to the pump and parts in direct contact with the process fluid, until reaching room temperature.

- ⤴ carefully read Chapter 5 relating to assembly and disassembly of the LPDPG, before carrying out any maintenance or inspection operation of the LPDPG;
- ⤴ clean the outside of the pump before disassembly, as per section 3.4.1.1.

4.7 Instructions for restarting after a stop

In order to restart the LPDPG one must:

- ⤴ open the valves placed on the suction and discharge side;
- ⤴ pressurise, if present on the LPDPG, the pneumatic safety valve on the front cover;
- ⤴ intervene on the electric control panel, present on the machine or plant of the Customer, and:
 - move the selector from position "0" to position "1" or "2", according to the rotation direction;
 - press the START button.

4.8 Switch-off

To switch off the LPDPG one must press the STOP key on the electric control panel present on the machine or on the plant of the Customer.

4.9 Emptying

To empty the LPDPG, after machine down time, one must operate in the machine as described below:

- ⤴ stop the plant, as described in section 4.6;
- ⤴ use a hex spanner to remove the screws of the front the front cover and move the cover away from the pumping chamber;
- ⤴ let the remaining fluid drain into a container to dispose of it according to the existing regulatory framework.

Once the excess fluid has drained from the pump body, fully remove the cover and continue with the required operations (maintenance, parts replacement, dismantling, etc.).

4.10 Residual risks

Listed below are the main residual risks that may occur in the LPDPG, deriving from the incorrect execution of one of the operations described in this OMM.

CAUSES THAT MAY GENERATE RESIDUAL RISKS	RESIDUAL RISKS
Removal of the front cover / Emptying / Leakage of fluid	Contact with dangerous process fluid
Incorrect earthing	Electric shock
Breakage of piping / Breakage of mechanical components	Ejection of process fluid
Incorrect or incomplete fixing of the pump Unit / Incorrect tightening of screws	Support vibrations and movements / Misalignment between pump Unit and piping of Customer plant
Incorrect calculation of performances (capacity, pressure, speed)	Rotors seizure, possible piping breakage
Incorrect closure of a valve upstream or downstream of the pump Unit	Water hammer with projection of cover
Presence of metallic cinders in the plant of the Customer	Possible seizure of rotors
Incorrect CIP/SIP	Contamination of process fluid
Leakage from sealing parts	Ejection of process fluid

4.11 Dangers generated by use

Incorrect use of the LPDPG, generated by failure to comply in full or in part with the use and maintenance instructions contained in this OMM, can cause technical dangers in the operation of the Customer plant.

Listed below are the incorrect ways to use the LPDPG.

INCORRECT USE	ARISING DANGERS
Use of the LPDPG for transfers of fluid in different conditions of hygienic level than those for which it has been of its organoleptic designed(*)	Contamination of process fluid or degradation of the organoleptic specifications
Incorrect execution of CIP/SIP	Possible contamination of process fluid
Failure to use personal protection equipment	Danger for health of operators in charge of using the plant of the Customer
Failure to comply with the procedures described in chapters 3 and 4 of this manual	Malfunctioning of the plant of the Customer / Risks for the health of operators

(*) The LPDPG for alimentary use has been designed to ensure hygiene Level 3, in accordance with EN 14159.

4.12 Prohibited use

The unintended uses of the LPDPG for chemical use or alimentary use are all those that are NOT covered under sections 1.4 and section 4.1.



ATTENTION

O.M.A.C. s.r.l. forbids any use not expressly indicated in this OMM and is not liable for any damage caused by unauthorised improper use of the LPDPG or with the process fluid.

4.13 Management of emergency situations

In the event of an emergency situation connected directly or indirectly to the LPDPG, one must stop machine operation, intervening on the electric control panel, present on the machine or plant of the Customer.

One can stop operation by pressing the emergency button, marked with letter "E" in section 4.2 of this chapter (red mushroom button on circular yellow base).

CHAPTER 5: MAINTENANCE

Where provided, the contents of this chapter is specifically addressed to the **internal company maintenance operator**. This person, named directly and formally by the Customer company management; has at least two years experience in this role and has the required technical abilities for operating in safety conditions and interpret the technical indications contained in the above mentioned documentation properly.



DANGER

Before disconnecting the LPDPG from its energy supplies, make sure that the plant or part of it is contained in complies with the following conditions:

- ▲ absence of product and eventually washing;
- ▲ absence of residual pressure;
- ▲ temperature of contact surfaces not dangerous.

Before carrying out any maintenance operation on the LPDPG pump, ensure one has carried out the pump and plant stopping operations, described in section 4.5 "Use of the line: stopping instructions"

During the LPDPG assembly and disassembly operations, as during its routine and extraordinary maintenance, one must wear the personal protection equipment, according to the operation and risk connected to the activity performed by the appointed operator, as described in section 1.9.

5.1 Troubleshooting and solving problems

<u>FAILURE: HIGH POWER ABSORPTION BY GPVL</u>	
<u>POSSIBLE CAUSES:</u>	<u>REMEDIES:</u>
Excessive medium viscosity	Decrease the speed of the pump, increase the temperature of the medium
Low medium temperature	Increase the temperature of the medium, heat the pumping case (within the limits given by the manufacturer)
Excessive back-pressure	Remove possible obstructions in the outlet piping, increase the piping diameter, reduce its length and the number of the bends
Too tight packing gland	Loosen the packing gland and tighten it rightly (see instructions)
Excessive pump speed	Decrease the speed of the pump
Piping press on pumping case	Check the piping alignment, if necessary fit flexible expansion joints, and fix the piping on the plant structure
Not aligned joint	Check the alignment between pump and drive device
Worn out bearings	Replace the bearings by the manufacturer
Worn out or untimed gears	Replace the gears or time them according to the instructions
Wrong quantity / quality of gears oil	Act according to the manufacturer's instructions
Parts in contact in the pumping case	Check the design pressure coincides with the operating pressure
Worn out rotors	Replace rotors

<u>FAILURE: GPVL JUST STARTING BLOCK</u>	
<u>POSSIBLE CAUSES:</u>	<u>REMEDIES:</u>
Excessive medium viscosity	decrease the speed of the pump, increase the temperature of the medium
Low media temperature	increase the temperature of the medium, heat the pumping case (within the limits given by the manufacturer)
Excessive back-pressure	Remove possible obstructions in the outlet piping, increase the piping diameter, reduce its length and the number of the bends
Worn out or untimed gears	replace the gears or time them according to the instructions
Parts in contact in the pumping case	Check the design pressure coincides with the operating pressure

<u>FAILURE: UNPRIMED OF THE PUMP</u>	
<u>POSSIBLE CAUSES:</u>	<u>REMEDIES:</u>
Insufficient N.P.S.H (Net Positive Suction Head)	Increase the head, the piping inlet diameter, reduce the suction piping length and the number of the bends, decrease the speed of the pump and the temperature of the medium, check that the increase (caused by the decreasing temperature) is suitable to the motor power
Medium evaporates in inlet	Increase the head, the piping inlet diameter, reduce the suction piping length and the number of the bends, decrease the speed of the pump and the temperature of the medium, check that the increase (caused by the decreasing temperature) is suitable to the motor power
Air enters in inlet	Check and tighten suction piping connections, tighten the packing glands and, if necessary, replace them
Presence of air in the suction	Fill pumping case and feeding piping with liquid, expelling air
Not enough liquid level in the tank in the suction	Increase medium level, lower suction opening position
Dirty or blocked valve or suction filter	Clean filters

<u>FAILURE: UNPRIMED OF THE PUMP</u>	
<u>POSSIBLE CAUSES:</u>	<u>REMEDIES:</u>
Excessive medium viscosity	Decrease the speed of the pump, increase the temperature of the medium
Too loose packing gland	Tighten the packing gland rightly (see instructions)
Excessive pump speed	Decrease the speed of the pump

<u>FAILURE: SEIZURE OF THE PUMP</u>	
<u>POSSIBLE CAUSES:</u>	<u>REMEDIES:</u>
Excessive medium temperature	Decrease the temperature of the medium, cool the pumping case
Presence of suspended particles in the medium	Clean suction piping and install a filter on it
Excessive back-pressure	Remove possible obstructions in the outlet piping, increase the piping diameter, reduce its length and the number of the bends
Too tight packing gland	Loosen the packing gland and tighten it rightly (see instructions)
Piping press on pumping case	Check the piping alignment, if necessary fit flexible expansion joints, and fix the piping on the plant structure
Worn out bearings	Replace the bearings by the manufacturer
Worn out or untimed gears	Replace the gears or time them according to the instructions
Wrong quantity / quality of gears oil	Act according to the manufacturer's instructions
Parts in contact in the pumping case	Check the design pressure coincides with the operating pressure

<u>FAILURE: NO FLOW-RATE</u>	
<u>POSSIBLE CAUSES:</u>	<u>REMEDIES:</u>
Wrong rotation direction	Invert the rotation direction
Unprimed pump	Fill pumping case and feeding piping with liquid, expelling air
Insufficient N.P.S.H (Net Positive Suction Head)	Increase the head, the piping inlet diameter, reduce the suction piping length and the number of the bends, decrease the speed of the pump and the temperature of the medium, check that the increase (caused by the decreasing temperature) is suitable to the motor power
Presence of air in the suction	Increase medium level, lower suction opening position
Dirty or blocked valve or suction filter	Clean filters
The relief valve leaks	Check the relief valve setting, clean sealing parts, substitute worn parts

<u>FAILURE: LDPU LOW FLOW-RATE</u>	
<u>POSSIBLE CAUSES:</u>	<u>REMEDIES:</u>
Insufficient N.P.S.H (Net Positive Suction Head)	Increase the head, the piping inlet diameter, reduce the suction piping length and the number of the bends, decrease the speed of the pump and the temperature of the medium, check that the increase (caused by the decreasing temperature) is suitable to the motor power
Medium evaporates in inlet	Increase the head, the piping inlet diameter, reduce the suction piping length and the number of the bends, decrease the speed of the pump and the temperature of the medium, check that the increase (caused by the decreasing temperature) is suitable to the motor power
Air enters in inlet	Check and tighten suction piping connections, tighten the packing glands and, if necessary, replace them
Presence of air in the suction	Fill pumping case and feeding piping with liquid, expelling air
Not enough liquid level in the tank in the suction	Increase medium level, lower suction opening position
Dirty or blocked valve or suction filter	Clean filters
Insufficient medium viscosity	Increase pump speed, decrease the temperature of the medium
Excessive medium temperature	Decrease the temperature of the medium, cool the pumping case
Excessive back-pressure	Remove possible obstructions in the outlet piping, increase the piping diameter, reduce its length and the number of the bends
Too loose packing gland	Tighten the packing gland rightly (see instructions)
Insufficient pump speed	Increase pump speed
Transmission belt slips	Stretch the belt
Worn out rotors	Replace rotors
The relief valve leaks	Check the relief valve setting, clean sealing parts, substitute worn parts
The relief valve is wrongly set	Check the relief valve setting and the spring compression in the way that the spring will open at a 10% more of the operating pressure
The relief valve vibrates	Check the relief valve setting, check and clean the valve

<u>FAILURE: PORTATA IRREGOLARE</u>	
<u>POSSIBLE CAUSES:</u>	<u>REMEDIES:</u>
Insufficient N.P.S.H (Net Positive Suction Head)	Increase the head, the piping inlet diameter, reduce the suction piping length and the number of the bends, decrease the speed of the pump and the temperature of the medium, check that the increase (caused by the decreasing temperature) is suitable to the motor power
Medium evaporates in inlet	Increase the head, the piping inlet diameter, reduce the suction piping length and the number of the bends, decrease the speed of the pump and the temperature of the medium, check that the increase (caused by the decreasing temperature) is suitable to the motor power
Air enters in inlet	Check and tighten suction piping connections, tighten the packing glands and, if necessary, replace them
Presence of air in the suction	Fill pumping case and feeding piping with liquid, expelling air
Not enough liquid level in the tank in the suction	Increase medium level, lower suction opening position
Dirty or blocked valve or suction filter	Clean filters
Too loose packing gland	Tighten the packing gland rightly (see instructions)
Excessive pump speed	Decrease the speed of the pump

<u>FAILURE: NOISE PUMP AND LDPU VIBRATION</u>	
<u>POSSIBLE CAUSES:</u>	<u>REMEDIES:</u>
Insufficient N.P.S.H (Net Positive Suction Head)	Increase the head, the piping inlet diameter, reduce the suction piping length and the number of the bends, decrease the speed of the pump and the temperature of the medium, check that the increase (caused by the decreasing temperature) is suitable to the motor power
Medium evaporates in inlet	Increase the head, the piping inlet diameter, reduce the suction piping length and the number of the bends, decrease the speed of the pump and the temperature of the medium, check that the increase (caused by the decreasing temperature) is suitable to the motor power
Air enters in inlet	Check and tighten suction piping connections, tighten the packing glands and, if necessary, replace them
Presence of air in the suction	Fill pumping case and feeding piping with liquid, expelling air
Not enough liquid level in the tank in the suction	Increase medium level, lower suction opening position
Dirty or blocked valve or suction filter	Clean filters
Excessive medium viscosity	Decrease the speed of the pump, increase the temperature of the medium
Excessive medium temperature	Decrease the temperature of the medium, cool the pumping case
Presence of suspended particles in the medium	Pulire la tubazione di alimentazione, installare un filtro di alimentazione
Too loose packing gland	Tighten the packing gland rightly (see instructions)
Excessive pump speed	Decrease the speed of the pump
Piping press on pumping case	Check the piping alignment, if necessary fit flexible expansion joints, and fix the piping on the plant structure
Not aligned joint	Check the alignment between pump and drive device
Pump or drive device not fixed on the base	Tighten bolts and re-check the alignment between pump, device and joint
Worn out bearings	Replace the bearings by the manufacturer
Worn out or untimed gears	Replace the gears or time them according to the instructions
Wrong quantity / quality of gears oil	Act according to the manufacturer's instructions
Parts in contact in the pumping case	Check the design pressure coincides with the operating pressure
The relief valve vibrates	Controllare la regolazione della valvola, ispezionare e pulire la valvola
The relief valve is wrongly set	Check the relief valve setting and the spring compression in the way that the spring will open at a 10% more of the operating pressure

<u>FAILURE: OVERHEATING OF THE PUMP</u>	
<u>POSSIBLE CAUSES:</u>	<u>REMEDIES:</u>
Excessive medium viscosity	Decrease the speed of the pump, increase the temperature of the medium
Excessive medium temperature	Decrease the temperature of the medium, cool the pumping case
Excessive back-pressure	Remove possible obstructions in the outlet piping, increase the piping diameter, reduce its length and the number of the bends
Too tight packing gland	Loosen the packing gland and tighten it rightly (see instructions)
Piping press on pumping case	Check the piping alignment, if necessary fit flexible expansion joints, and fix the piping on the plant structure
Not aligned joint	Check the alignment between pump and drive device
Worn out bearings	Replace the bearings by the manufacturer
Worn out or untimed gears	Replace the gears or time them according to the instructions
Wrong quantity / quality of gears oil	Act according to the manufacturer's instructions
Parts in contact in the pumping case	Check the design pressure coincides with the operating pressure

FAILURE: OVERHEATING OF THE PUMP**POSSIBLE CAUSES:****REMEDIES:**

The relief valve leaks

Check the relief valve setting, clean sealing parts, substitute worn parts

FAILURE: OVERHEATING OF THE MOTORIZATION**POSSIBLE CAUSES:****REMEDIES:**

Low medium temperature

Increase the temperature of the medium, heat the pumping case (within the limits given by the manufacturer)

Excessive medium viscosity

Decrease the speed of the pump, increase the temperature of the medium

Excessive back-pressure

Remove possible obstructions in the outlet piping, increase the piping diameter, reduce its length and the number of the bends

Too tight packing gland

Loosen the packing gland and tighten it rightly (see instructions)

Excessive pump speed

Decrease the speed of the pump

Piping press on pumping case

Check the piping alignment, if necessary fit flexible expansion joints, and fix the piping on the plant structure

Not aligned joint

Check the alignment between pump and drive device

Worn out bearings

Replace the bearings by the manufacturer

Worn out or untimed gears

Replace the gears or time them according to the instructions

Wrong quantity / quality of gears oil

Act according to the manufacturer's instructions

Parts in contact in the pumping case

Check the design pressure coincides with the operating pressure

Worn out rotors

Replace rotors

FAILURE: FAST ROTORS WEAR**POSSIBLE CAUSES:****REMEDIES:**

Excessive medium temperature

Decrease the temperature of the medium, cool the pumping case

Presence of suspended particles in the medium

Clean suction piping and install a filter on it

Excessive back-pressure

Remove possible obstructions in the outlet piping, increase the piping diameter, reduce its length and the number of the bends

Piping press on pumping case

Check the piping alignment, if necessary fit flexible expansion joints, and fix the piping on the plant structure

Worn out bearings

Replace the bearings by the manufacturer

Worn out or untimed gears

Replace the gears or time them according to the instructions

Parts in contact in the pumping case

Check the design pressure coincides with the operating pressure

FAILURE: FAST SEALS WEAR**POSSIBLE CAUSES:****REMEDIES:**

Presence of suspended particles in the medium

Clean suction piping and install a filter on it

Too tight packing gland

Loosen the packing gland and tighten it rightly (see instructions)

Insufficient flushing seal liquid level

Check the flushing seal liquid and, if necessary, increase its flow-rate

5.2 Instruction for carrying out checks

Before any maintenance intervention one must provide all the security measures that comply with the accident prevention regulations in force. In particular inhibit operation of all electric utilities and discharge any residual energy.

The instruments and tools needed for good maintenance are those normally supplied as standard to a technician with assembly/maintenance tasks.

In the case the machine is positioned above ground level it is up to the Customer to make the machine accessible to the operator in order to permit adjustment, maintenance, repair, etc. operations possible, in safety conditions.

- ▲ In the case the process fluid is subject to easy drying, crystallisation or sedimentation, it is essential to wash the pump and pipes at the end of each operation, i.e. at the beginning of extended machine down time.
- ▲ The reversibility of the rotation direction, common feature of all OMAC pumps, offers the possibility to recall the process fluid, completely emptying the delivery pipes and putting the product in storage.
- ▲ If the LPDPG is not use for a long period of time, when starting check that the sealing parts are not blocked by turning the pump shaft manually.
- ▲ If the process fluid is subject to freezing or solidification, ensure before starting, that the pipes and the pump body are not obstructed by solid parts of fluid, formed during inactivity.

The references below, with position number, are intended as the exploded view drawing of the LPDP indicated in section 1.3.

5.2.1 Daily checks

- ▲ Visual inspection of all sealing parts and of the general operation of the LPDPG.
- ▲ If one experiences a loss of mechanical seals, see to replace them as soon as possible, to prevent the process fluid from entering the bearings box or stagnating on the ground.

5.2.2 Weekly checks

- ⤴ Check the oil level of the pump and motor unit, eventually top-up with oil of the kind indicated by the manufacturers, after having checked the proper amount and the degree of viscosity on the respective use and maintenance manuals.
- ⤴ Inspect the pumping chamber and free it from any scaling due to the kind of process fluid.
- ⤴ Check that there is no seizing between the rotors and the static surfaces of the pumping body.
- ⤴ Check that the mechanical safety valve on the cover, when provided, is not blocked by a long period of inactivity. To check simply remove the adjustment screw completely (pos.59 page 29) and then adjust the calibrations of the spring again.

5.2.3 Six monthly checks

- ⤴ If the LPDPG works constantly at high temperatures, above 120°C, check the integrity of the pump lubricant oil; if it has gone dark in colour, see to its replacement. The same goes for the motorisation unit; keep to the instructions of the manufacturer.
- ⤴ Check that the distribution gears have not reached such a play to enable the rotors to come into contact; in this case replace the worn gears.
- ⤴ Check the stiffness of the shafts: if there is even minimal axial or radial play, see to the replacement of the bearings.
- ⤴ Check the corrosion condition of the bearings box; if needed re-paint with suitable paint and protect it from premature wear. The LPDPG is painted as standard with EPOXY ENAMEL GLOSS RAL 7032.



NOTE

By systematically following these checks, the pump will maintain its original performances unchanged for many years.

5.3 Periodic checks of the safety and emergency devices

When the LPDPG is fitted with an electric control panel, one must carry out weekly checks for the correct operation of the actuators and operation of the relative warning lights.

5.4 Indication of dangerous temperature

In the event of pumps predisposed for pumping products at high temperatures up to 150°C, there is a signal placed on the same pump that warns the operators of the presence of high temperature surfaces, as shown in figure:



5.5 Oils present

- ⤴ Check the oil level placed on the side of the pump daily; it must always be completely full when the pump is switched off.
- ⤴ If needed, restore the level by adding oil with reference to section 1.3.12 of this OMM, relating to the degree of viscosity and the proper amount, expressed in litres, for every LPDPG size.
- ⤴ If the pump is used with vertical openings, check the proper position of the vent cap and level and if needed invert them.
- ⤴ Oil replacement must take place after a run-in period of about 150 working hours, subsequently every 2500 hours.
- ⤴ If the gear box works constantly at temperatures above 90°C, lubricate with oil with a higher degree of viscosity (see section 1.3.12) and replace it every 1000 working hours.

5.6 Tests and checks

Listed below are the checks to be performed, at predetermined intervals, on the LPDPG.

5.6.1 Lubrication

The LPDPG has other mechanical elements that during maintenance require lubrication: these components are the sealing parts. In assembly and disassembly operations there are the specifications relating to the surfaces to be lubricated with grease and the stages in which this operation must be carried out.

5.6.2 Single mechanical seals

- ⤴ Mechanical seals do not require any maintenance.
- ⤴ When there is a leak, caused by wear and contact surfaces, see to replace the whole seals (see disassembly instructions).
- ⤴ In case of extended operation with worn seals, check that some process fluid leaks outside the pumping body.



IMPORTANT: it is recommended to not let the mechanical seals turn when dry.

5.6.3 Mechanical seals with flushing

- ⤴ Flushed mechanical seals, as simple mechanical seals, do not require any maintenance;
- ⤴ When one replaces the mechanical seal, also replace the rotating ring (pos. 224) and the lip ring (pos. 223) of the auxiliary seal.
- ⤴ With flushing connected adequately, the pump can operate even in absence of the product to be pumped, because the seals do not risk overheating;
- ⤴ Check that flushing is always efficient, when the pump is operating, in order not to damage the auxiliary seals (connection diagram section 3.5.2);
- ⤴ To disassemble the flushed mechanical seals, follow the instructions of the simple mechanical seals, described in this chapter;

- ✦ To remove the fixed part of the mechanical seal, disassemble the chamber (pos. 22) from the pumping body;
- ✦ When assembling, before inserting the rotating part of the mechanical seal on the shaft, position the rotating ring properly (pos. 224) and fit the auxiliary sealing ring adequately (pos. 223) in its housing on the chamber (pos. 220), as per the section drawings in chapter 7, in the sections relative to the sealing parts.

The purpose of flushing mechanical seals is generally to cool down and lubricate the sliding faces of the mechanical seal, via forced circulation of a flushing liquid.

The flushing liquid and its distribution circuit must be provided by the Customer. **The Customer must also check, through his Technical Office, the compatibility between the flushing liquid and the process fluid, as well as the compatibility between the flushing liquid and the components of the LPDP in close contact (pumping chamber material, seals material, working temperature, etc.)**

Once this requirement has been checked and validated, the Technical Office of the Customer will see to expressly authorise the operator responsible for the installation of the LPDPG to fit the flushing circuit on the seals flushing chamber and commission it, before starting the LPDPG for the first time.



ATTENTION

The operator responsible for fitting the flushing circuit must be expressly authorised by the Technical Office of the Customer to connect the same flushing circuit to a system that uses "flushing liquid" compatible with the process fluid.

O.M.A.C. s.r.l. is not responsible for improper use of the flushing liquid nor for damages deriving from contamination of the process fluid.



DANGER

Improper use of the flushing system can cause breakage of the mechanical seals with consequent damage of the LPDPG and contamination of the process fluid.

O.M.A.C. s.r.l. is not responsible for improper use of the flushing system.

The operator designated by the Customer must connect the flushing circuit joints to the input and output holes of the seals flushing chambers and adjust the temperature and pressure according to the type of seal fitted on the displacement pump, as described below:

- ✦ in case of single mechanical seals the flushing pressure must be about 1.5 - 2 bar and a flow-rate of 0.5-1 l/min ;
- ✦ in the case of double mechanical seals the flushing pressure must be equal to the working pressure or higher by 1 bar, to ensure that the film created between the sliding faces of the seals is made up of the flushing liquid and not by the process fluid, which according to its chemical composition may crystallise and solidify after machine down time and generate, upon restarting the unit, a "sticking" phenomenon of the faces, causing their breakage.

The flushing temperature must be established according to the type of processed fluid and to the flushing utility: generally using liquid at room temperature - about 15° - 20° - is necessary to disperse the heat generated by friction of the seals faces, or vice-versa, using liquid at higher temperatures, for example 80° - 90°, can be useful for melting, removing, cleaning and lubricating the seals faces.

The dimensions of the inlet and outlet holes joints of the flushing circuit are listed in the table in section 1.3.9 in chapter 1.

5.6.4 Mechanical seals balancing

All mechanical seals fitted on the LPDPG are equipped with a balancing ring of the fixed parts, to cope with severe operating conditions such as:

- ✦ pressure peaks due to the first break-away or start-ups under load;
- ✦ particularly viscous or sticky product;
- ✦ frequent start-ups.

IMPORTANT: the balancing ring must not strain on the fixed part of the seal; check that there is slight play (about 0.05/0.3 mm).

5.7 Disassembly and assembly operations of BA BB BF100 size pump

This section lists the disassembly / assembly operations of the BA BB BF100 size lobe pump.

BA BB BF100 Section

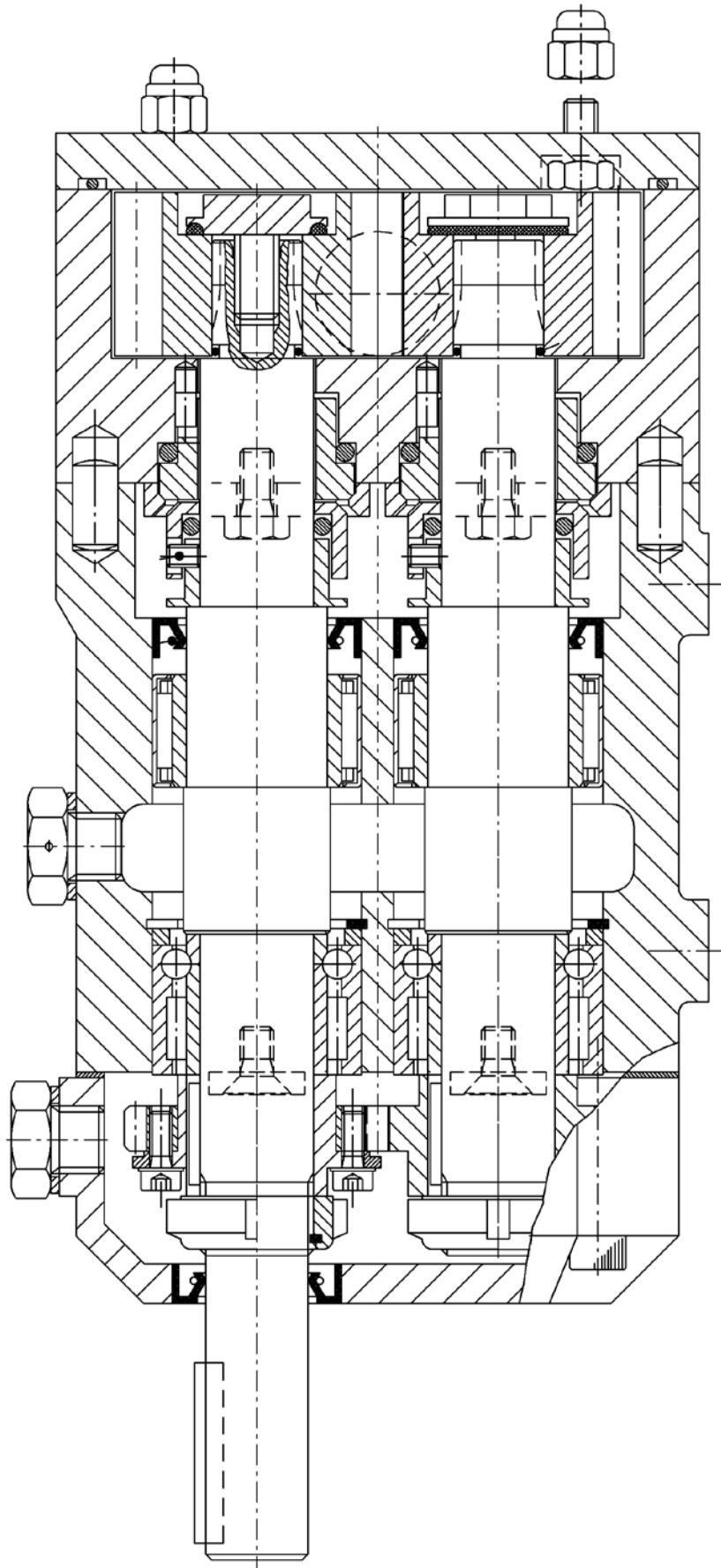

5.7.1 Disassembly of the pumping body

Before removing the cover, ensure that the pump and motor are insulated, that the pump is cold enough to be touched safely, that all fluids have been discharged and make sure that the pump body is insulated and de-pressurised. If the end cover is fitted with a by-pass valve consult the relative section. Then proceed as follows:

1 Remove the front nuts and exert leverage in the provided slots on cover

2 Unscrew anticlockwise the rotor nuts, interposing a non metal element between the rotors, making them stop rolling

3 Take care of the reference marked on rotors and shafts (1-2) so that you will set them rightly while reassembling

4 Extract the rotors, taking care you don't damage them by means of metal tools

5 extract the rotor case

6 Extract the rotating part of the mechanical seal from the shaft, after disassembling the bearing retainers

7 Untighten the socket head screws on mechanical seal

8 Extract the rotating part of the mechanical seal from the shaft

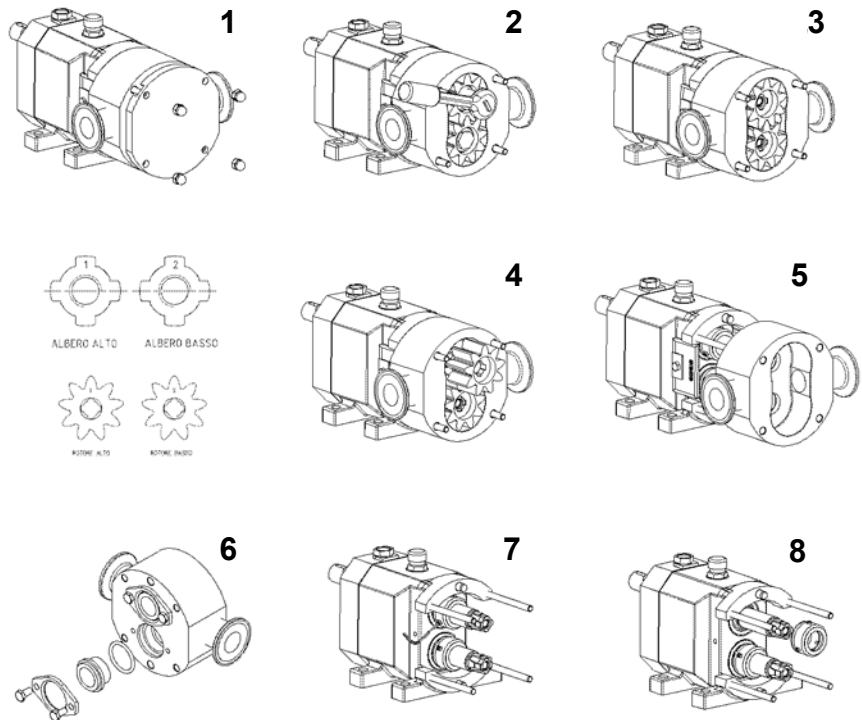

5.7.2 Assembly of the pumping body



ATTENTION

9 During the following operations, take care you don't damage the lapped seal surface; don't lay them on the bench and handle them with clean hands

10 Clean carefully the shafts. Lubricate lightly the O-ring and introduce the rotating part of the seal, possibly by means of a conical bush. Exert pressure only with hands; avoid using metal tools

11 Be sure the mechanical seals stand on the shaft shoulder and tighten step by step the socket head screws. We suggest you should use a thread locking adhesive in order to avoid their untightening on work

12 Assemble the stationary part of the seal on rotor case, taking care to align the slot with the retainer pin, already arranged on seat bottom

13 Clean carefully the seal slide surfaces and assemble the rotor case delicately in order not to damage the seals and be sure it is well set on plugs. Clamp the back nuts

14 Assemble the rotors, setting them on pitch setting, according to reference marks (1-2). Clamp the rotor nuts (see cap.1.3.6). In order to stop turning, interpose a non metal element between rotors

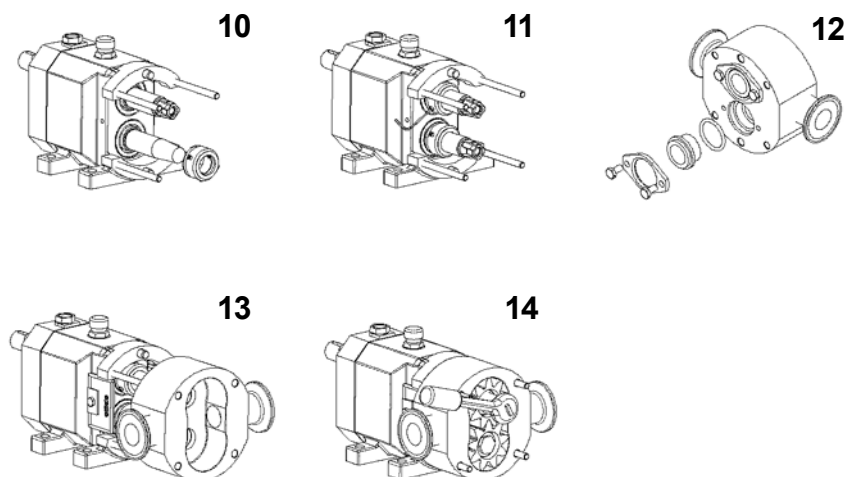

5.7.3 Disassembly of the bearing box

15 After disassembling the rotor case, drain the oil and remove the drive key on shaft

16 Remove the gear cover and make a reference mark on gears in order to respect the right timing while reassembling

17 Disconnect the retainer keys on lock washers

18 Unscrew the gear ring nut, inserting a non metal wedge between gears in order to stop turning

19 Disassemble the shafts, unscrewing the flathead screw, with the lock washer

20 Extract the shafts by the posterior side of the pump

21 Extract the oil retainer and the external rings of the front bearing

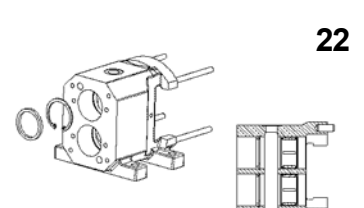
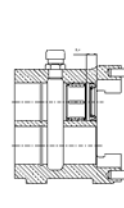
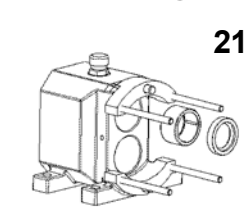
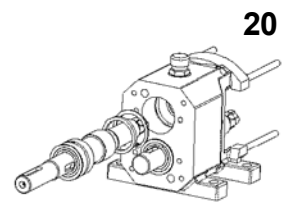
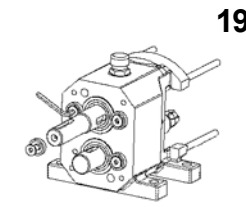
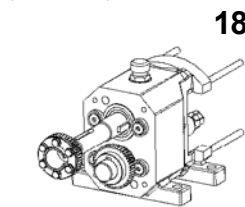
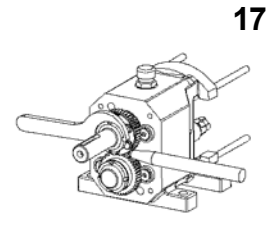
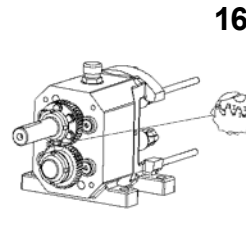
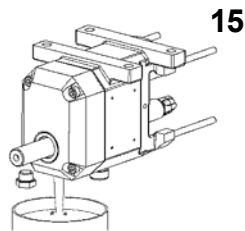

22 extract the spacers and the snap rings

5.7.4 Assembly of the bearing box

23 *BEARING ASSEMBLING PHASE*

Prepare the shafts and the bearings, checking they are without dents and burrs

24 Drive the inner ring on the driving shaft. Repeat the operation on the driven shaft

25 Assemble the rear bearing on the driving shaft and then on the driven one

26 Drive the external bearing rings on the gear box, observing the depth on the figure (10 mm)

27 Insert the snap rings and the spacers for the axial setting

28 Assemble the shafts by the rear side of the pump, respecting the timing previously marked while reassembling, with the numbers marked "1" and "2" turned towards the high

29 Fixed the rear bearings with the washers and the flathead screws

30 The gear couple is composed by a fixed gear and an adjustable one. Assemble the fixed gear, then the adjustable one with untightened screws, taking care to a first approximate rotor timing

31 Tighten the retainer ring nuts with the corresponding safety washers and set rightly the suited retainer key. In order to avoid turning during operation insert a wedge in soft material among the gear teeth

32 Assemble the rotor case and rotors as previously described and check the "Clearances" (see par.1.3.4).

If rotor clearances are not included in tolerances as prescribed in chap. 1, disassemble rotors, the rotor case and adjust the spacer according to the requested dimension

33 Being the wedge inserted among the gears tighten the rotor nuts, taking care of the driving torque (see par.1.3.6)

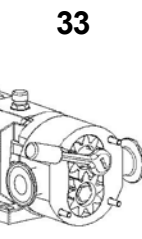
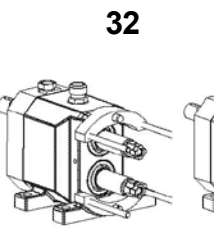
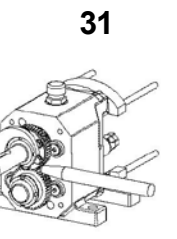
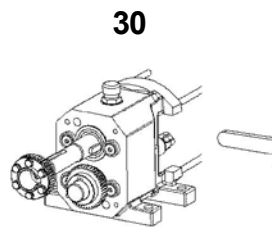
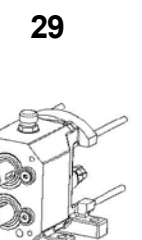
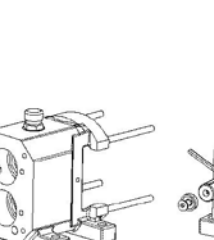
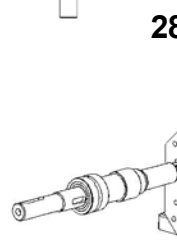
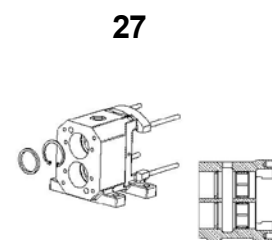
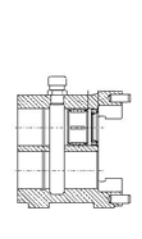
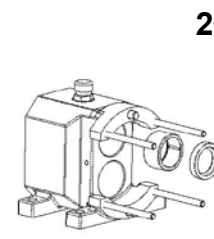
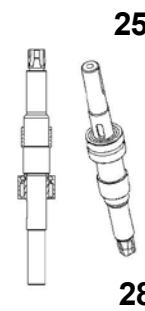
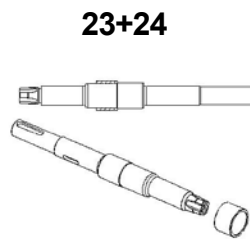

34 Time perfectly the rotors and tighten the screws of the adjustable gear gradually, checking the rotor timing

35 Tighten completely the adjustable gear screws taking care of the driving torque (see par.1.3.6)

N.B. IN CASE OF RE-TIMING IT'S NECESSARY TO REPLACE THE PLANE WASHERS, CAVED BY PREVIOUS CLAMPING

36 Assemble the gear cover, taking care to set the O-ring gasket and insert the key on the shaft. Put into bearing housing the oil quantity as per chap.1.3.12

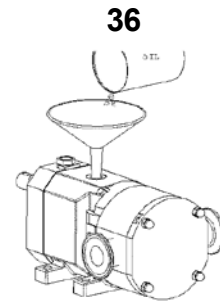
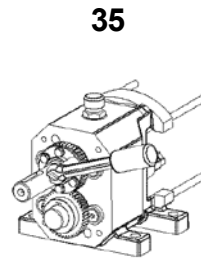
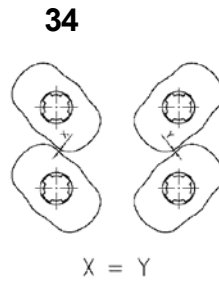

5.8 Disassembly and assembly operations of BA BB BF 1 / BA BB BF 2 / BA BB BF 3 / BA BB / BA BB 470 / BA BB 490 size pump

This section lists the disassembly / assembly operations of the BA BB BF1 / BA BB BF 2 / BA BB BF 3 / BA BB 4 / BA BB / BA BB 490 size lobe pump.

BA BB BF105 – BA BB BF110 – BA BB BF115 Section

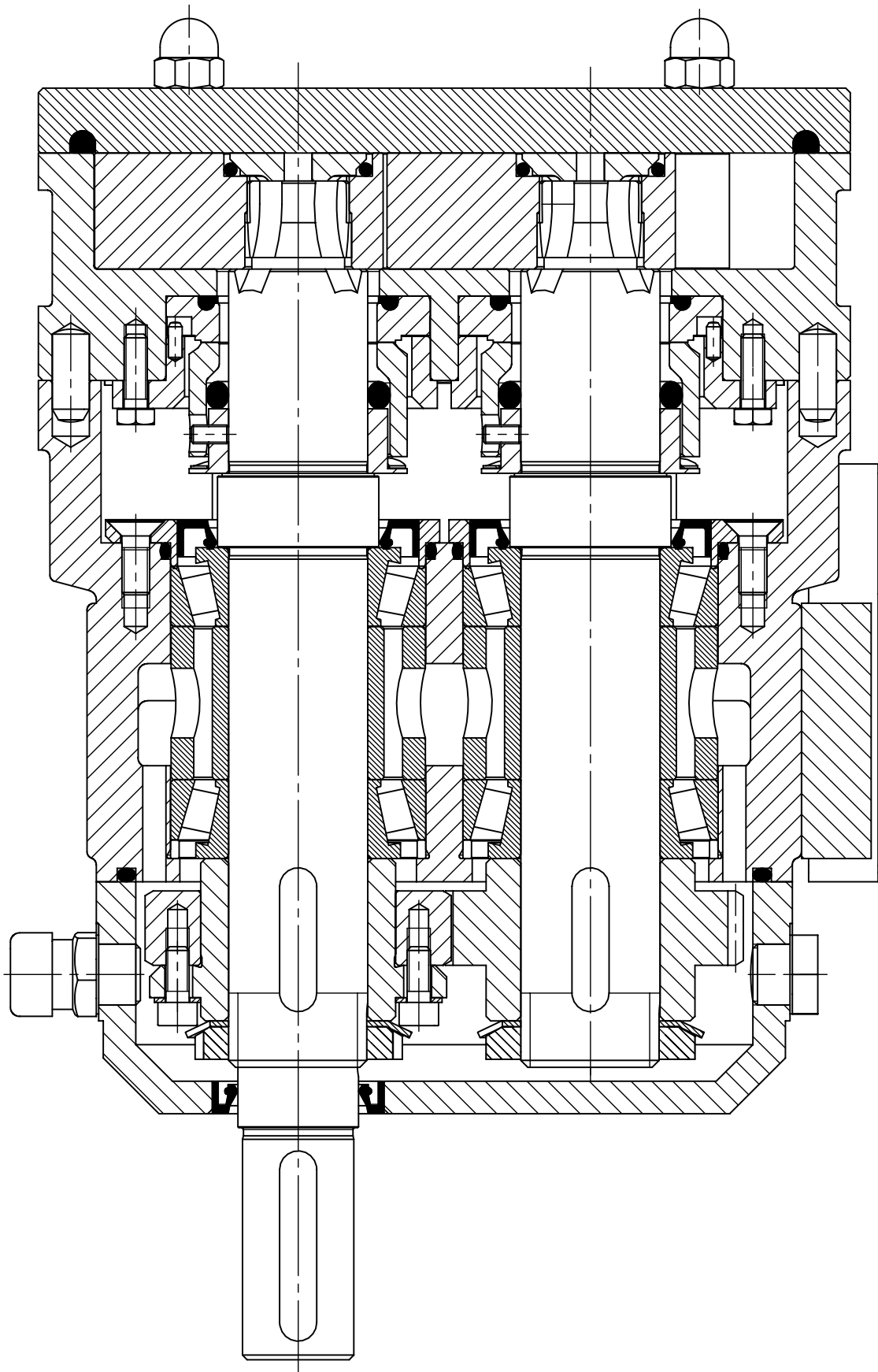

BA BB BF 2 – BA BB BF 3 – BA BB 4 – BA BB 470 - BA BB 490 Section

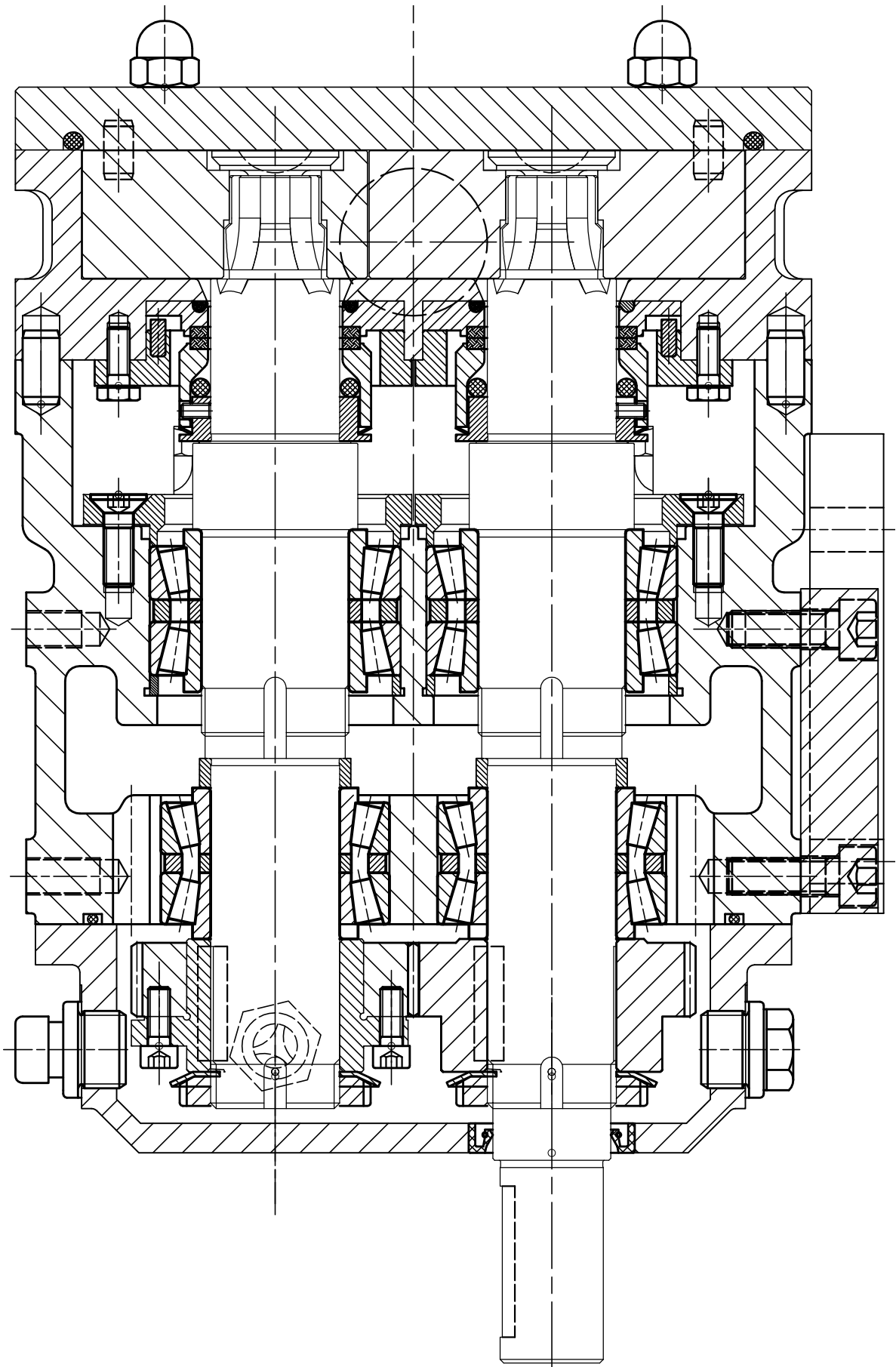

5.8.1 Disassembly of the rotorcase

1 Remove the front nuts and exert leverage in the provided slots on cover

2 Unscrew anticlockwise the rotor nuts, interposing a non metal element between the rotors, making them stop rolling

3 Take care of the reference marked on rotors and shafts (1-2) so that you will set them rightly while reassembling

4 Extract the rotors, taking care you don't damage them by means of metal tools

5 Unscrew the back nuts and extract the rotor case

6 Extract the stationary part of the mechanical seal from rotor case

7 Untighten the socket head screws on mechanical seal

8 Extract the rotating part of the mechanical seal from the shaft

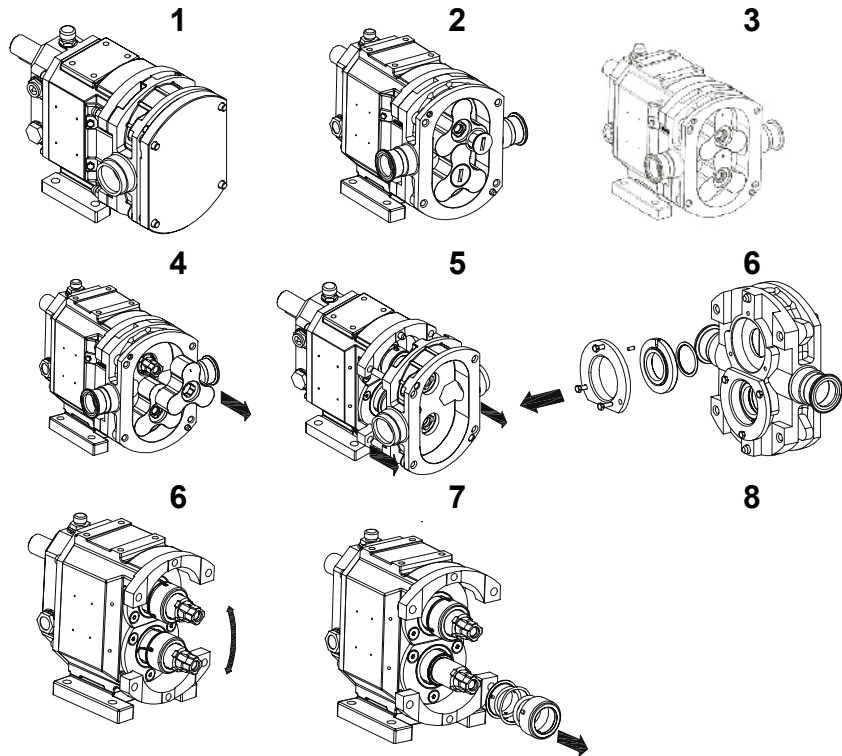

5.8.2 Assembly of the rotorcase



ATTENTION

9 During the following operations, take care you don't damage the lapped seal surface; don't lay them on the bench and handle them with clean hands

10 Clean carefully the shafts. Lubricate lightly the O-ring and introduce the rotating part of the seal, possibly by means of a conical bush. Exert pressure only with hands; avoid using metal tools

11 Be sure the mechanical seals stand on the shaft shoulder and tighten step by step the socket head screws. We suggest you should use a thread locking adhesive in order to avoid their untightening on work

12 Assemble the stationary part of the seal on rotor case, taking care to align the slot with the retainer pin, already arranged on seat bottom

13 Clean carefully the seal slide surfaces and assemble the rotor case delicately in order not to damage the seals and be sure it is well set on plugs. Clamp the back nuts

14 Assemble the rotors, setting them on pitch setting, according to reference marks (1-2). Clamp the rotor nuts (see cap.4.5). In order to stop turning, interpose a non metal element between rotors

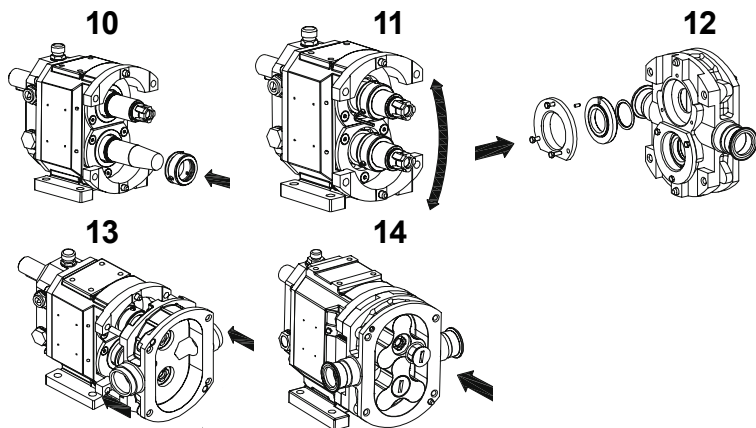

5.8.3 Disassembly of the bearings box

15 After disassembling the rotor case, drain the oil and the remove drive key on shaft

16 Remove the gear cover and make a reference mark on gears in order to respect the right timing while reassembling

17 Disconnect the retainer keys on lock washers

18 Unscrew the gear ring nut, inserting a non metal wedge between gears in order to stop turning

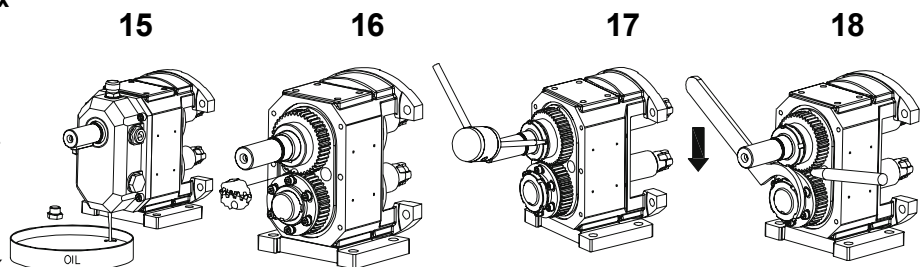

19 Extract the gears, exerting leverage between the bearing housing and the gears side, without damaging the toothing outline

20 On assembling and disassembling we suggest you should replace the gears with a spacer in order not to break down the pre-assembled bearing

21 Remove the bearing retainers

22 Extract the shafts by means of a non metal hammer

23 Mark the spacers for the axial shaft adjustment, then replace them rightly while re-assembling

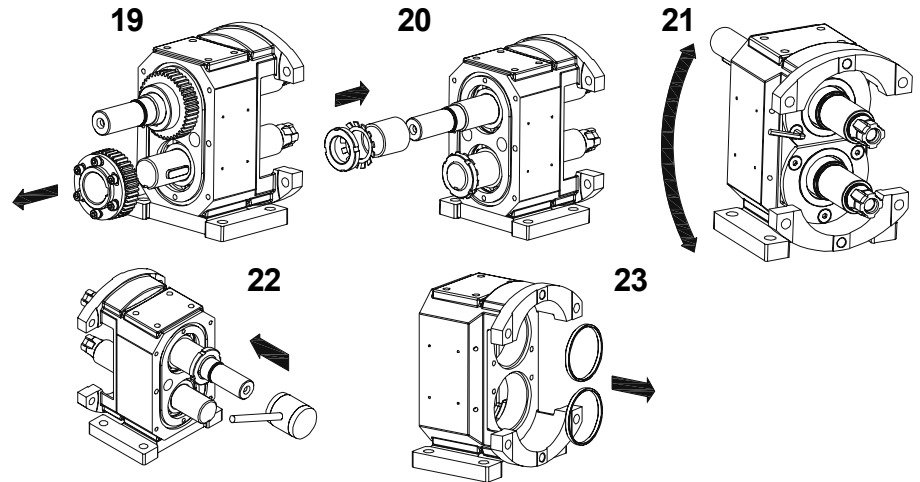

5.8.4 Assembly of the bearings box

24 *FRONT BEARING ASSEMBLING PHASE1*

If you replace bearings with others that are not supplied by OMAC, you must mark, with the electric pen, the internal ring of a bearing with the # symbol. Check with depth micrometer gauge the dimension "x" according to the table, take it without the inner spacer and the inner ring with roller set on the opposite side of #

25 PHASE 2

USE GLOVES. Heat the inner ring # up to ca 150° C and assemble it on the shaft. Wait for the temperature to drop to room temperature. Value of the measurement "X" (+/- 0.02)

26 PHASE 3

Assemble the bearing. Insert the inner spacer the first time just lapped with lapping machine. Consider the axial clearance between the rollers and carry out another lapping until you obtain a preloading on the bearings of about 0,05 mm. The best assembling is obtained when the bearings, tightened with the ring nut, roll freely and the outer spacer is slightly blocked but moves exerting a radial pressure with fingers. For tightening torques see chap. 1

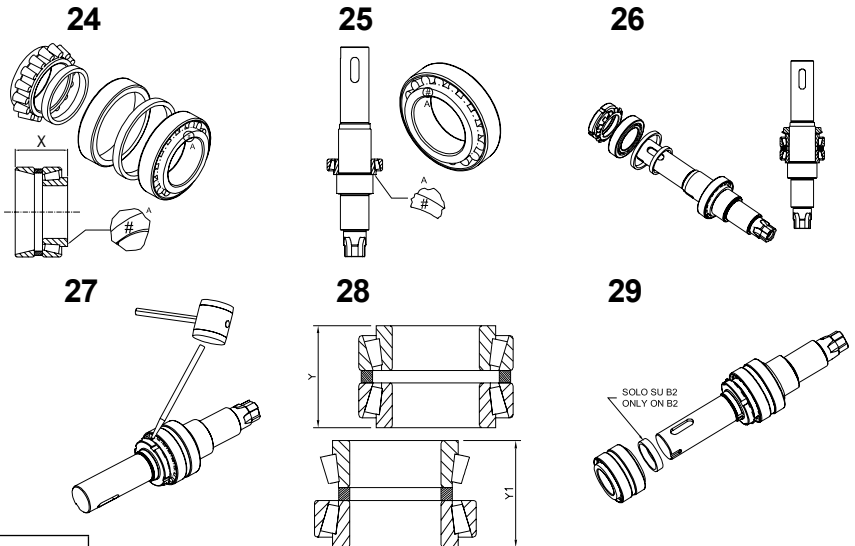

Size 1	Size 2	Size 3	Size 4	Size 470-490
63mm	39.5mm	41.4mm	50.9mm	66mm

Dimension X ± 0.02

27 Assemble the pre-assembled front bearing, tighten firmly the ring nut and set the retainer key in the ring nut slot

IMPORTANT: Put all keys of the safety washer up to the ring nut in order to let the spacer pass for the axial adjustment

28 REAR BEARING ASSEMBLING PHASE1

Measurement of the "Y" dimension without the inner spacer

29 ATTENTION Bearing spacer (pos. n°10 fi g.12.2) has to be placed only on size.

30 PHASE 2

Measurement of the "Y1" dimension without the outer spacer, without an outer ring and with the inner spacer, which must be inserted the first time just lapped, then the second time with the correct measure in such a way that: $Y1 = Y - 0.05$

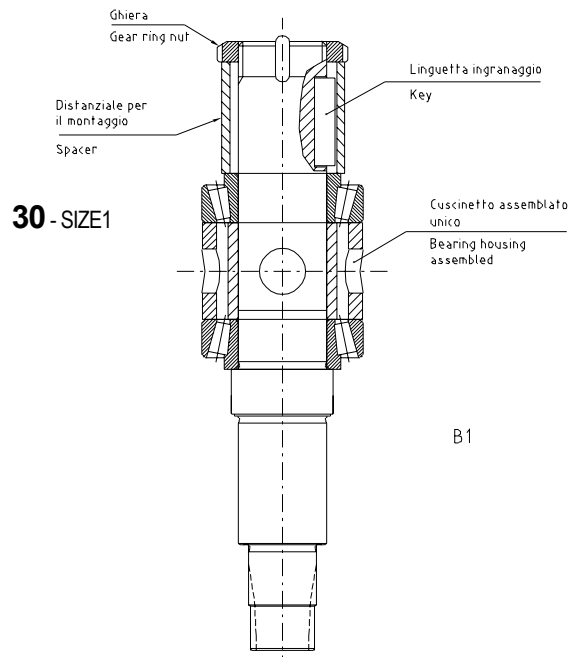

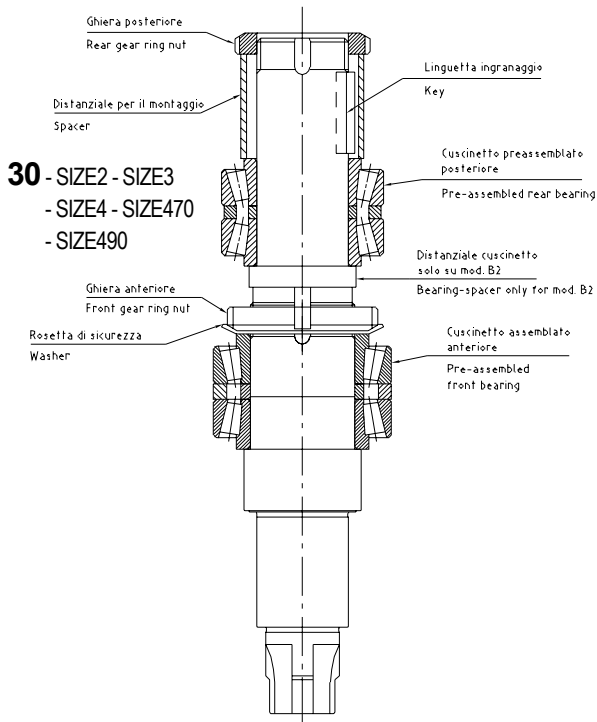

30 - SIZE2 - SIZE3
- SIZE4 - SIZE470
- SIZE490

31 Assemble the pre-assembled rear bearing, tighten the ring nut inserting a spacer suitable for replacing the gear, in order to keep assembled the bearing during the assembling operations

32 Set the spacers for axial shaft adjustment and assemble the shafts with the already fixed bearings

33 Set the O-ring gasket in its seat and assemble the bearing retainers with oil lip seal already fixed. Assemble the rotor case and rotors as previously described and check the "Clearances" (see chap.1)

34 If rotor clearances are not included in tolerances as per chap. 1, disassemble rotors, the rotor case and adjust the spacer according to the requested dimension. N.B. A spacer set can be requested to the manufacturer company

35 Remove the spacers used for the assembly and insert the keys for gear drive in their seats with a lightly forced connection

36 The gear couple is composed by a fixed gear and an adjustable one. Assemble the fixed gear, then the adjustable one with untightened screws, taking care to a first approximate rotor timing

37 Tighten the retainer ring nuts with the corresponding safety washers and set rightly the suited retainer key. In order to avoid turning during operation insert a wedge in soft material among the gear teeth

38 Being the wedge inserted among the gears tighten the rotor nuts, taking care of the driving torque (see chap.1)

39 Time perfectly the rotors and tighten the screws of the adjustable gear gradually, checking the rotor timing
N.B. IN CASE OF RE-TIMING IT'S NECESSARY TO REPLACE THE PLANE WASHERS, CAVED BY PREVIOUS CLAMPING
Tighten completely the adjustable gear screws taking care of the driving torque (see chap.1)

40
Assemble the gear cover, taking care to set the O-ring gasket and insert the key on the shaft.
Put into bearing housing the oil quantity as per chap.1

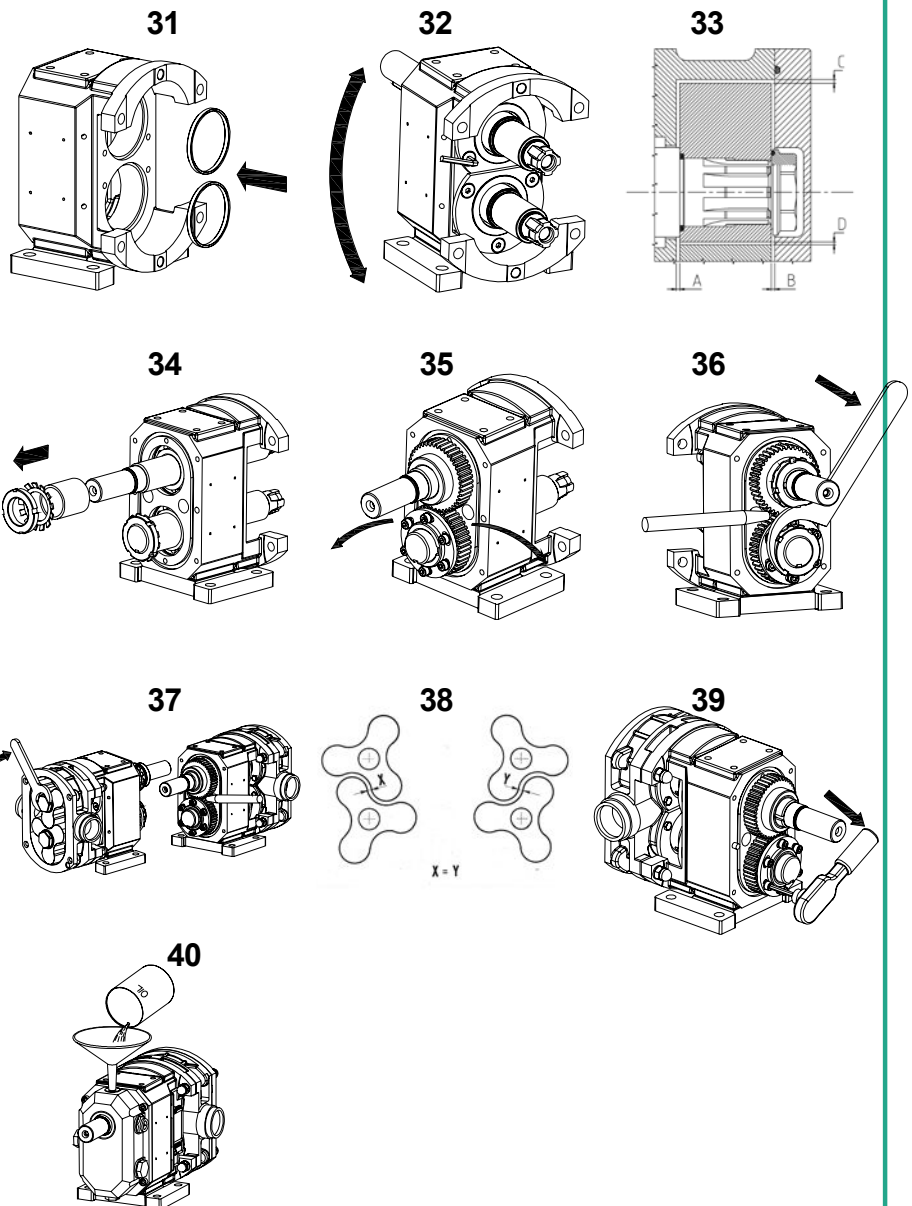

5.9 Post maintenance check

After maintenance activities, one must carry out tests to ensure the proper operation of the LPDPG, before restarting the unit. To carry out these tests refer to the check-list of section 4.5.1 of this OMM.

CHAPTER 6: DECOMMISSIONING

Where provided, the contents of this chapter is specifically addressed to the internal company maintenance engineer. This person, named directly and formally by the Customer company management; has at least two years experience in this role and has the required technical abilities for operating in safety conditions and understand and interpret the technical indications contained in the above mentioned documentation properly.

During assembly and disassembly operations of the LPDPG, as in occasion of its routine and extraordinary one must wear the personal protection equipment, according to the operation and risk connected to the activity performed by the appointed operator, as described in section 1.9.

6.1 Disconnection from the sources of energy



DANGER

Before disconnecting the LPDPG from its energy supplies, make sure that the plant or part of it is contained in complies with the following conditions:

- ⤴ absence of process fluid and eventually washing of parts in contact with process fluid;
- ⤴ absence of residual pressure;
- ⤴ temperature of contact surfaces not dangerous.

As already highlighted inside this use and maintenance manual, the LPDPG must be disconnected from the energy sources:

- ⤴ electric (motorisation);
- ⤴ hydraulic (driving force, flushing and/or aseptic unit when present);
- ⤴ pneumatic (driving force, pneumatic safety valve, when present).

Disconnection of the LPDPG from the energy sources requires strict compliance with the indications below:

- ⤴ with reference to Chapter 4, stop operation of the LPDPG (of every component) and consequently stop operation of the plant;
- ⤴ once operation of the LPDPG has been stopped, put every main switch in the plant in position "0", so that every part of the line is insulated from the power network (electric, etc.);
- ⤴ make sure that the various "presence of voltage" warning lights are switched off;
- ⤴ if an aseptic system and/or flushing system are present, make sure that the auxiliary liquid supply hydraulic control unit is switched off;
- ⤴ when the LPDPG requires compressed air to operate (presence of pneumatic safety valve), move the compressed air supply/discharge tap lever in close/discharge position and wait for a few minutes. This way the machine is insulated from the pneumatic supply network and furthermore the residual energy present inside the pneumatic circuit is discharged;



DANGER

Before disconnecting the lobe pump from its energy supplies, make sure that the upstream energy supply has been interrupted, that the hydraulic supply has been interrupted, that the compressed air has been interrupted and there is no residual energy (i.e. for example: that the compressed air present in the pneumatic plant has been discharged). Also check that the compressed air supply tap of your plant is closed.

- ⤴ in case of electric supply, making sure that you do not have any parts of your body near the damp areas, remove the plug from the electric system of the machine, from the electricity socket;
- ⤴ if pneumatic supply is present, free the fixing of the pneumatic supply pipe;
- ⤴ if hydraulic supply is present, free the fixing of the hydraulic supply pipe;
- ⤴ pay utmost attention to possible leaks of remaining liquids. These leaks must be dried immediately in order to prevent slipping.

It is reminded that the operations needed to disconnect the LPDPG from its energy supplies, for the complexity of the numerous checks / tests to be carried out, must be performed by skilled personnel only.

Please be reminded that to operate the LPDPG may need electricity, hydraulics and compressed air; connections that need to be disconnected carefully, taking care to verify the absence of stored residual energy in addition to water leaks.



DANGER

if not formally authorised, do not attempt to disassemble parts of the LPDPG.

O.M.A.C. S.r.l. is not liable for damages to things or persons during disassembly carried out by unauthorised personnel.

6.2 Disassembly

With reference to chapter 3, using PPE and the tools described herein, free the pump from its fixings, following the indications, in section 3.3 (installation), in reverse order



ATTENTION

- ⚠ use the proper P.P.E.;
- ⚠ use the adequate tools;
- ⚠ follow the procedure described in section 3.3 in reverse order;
- ⚠ first of all disassemble the any optional features present on the pump;
- ⚠ unscrew the suction and delivery connections from the plant;
- ⚠ remove the fixing screws from the base;
- ⚠ extract the LPDPG from its position, using hoisting equipment.



DANGER

Considering the mass of the lobe pump, the hoisting and transfer stages must only be carried out by skilled personnel and under the direct supervision of technical personnel headed by the respective manufacturers.

- ⚠ using a clean cloth that does not leave any fluff, clean the external parts accurately (both externally and the easily accessible internal parts);



WARNING

For cleaning, only use a clean cloth that does not leave any fluff.

- ⚠ free the LPDPG from its anchoring;
- ⚠ the unit is now free from its anchoring and ready to be handled, as defined in chapter 2 of this UMM.

6.3 Storage after its use

After the disconnection and cleaning operations, put the LPDPG in its original packaging, fixing it and trying to ensure good stability. Using appropriate hoisting means, put the packed LPDPG in a dry sheltered place at room temperature.

6.4 Demolition and disposal

Following the indications of the European Community Directives in force at the time of demolition, the user must take care of the disposal of the materials that make up the machine.

It is good practice for the user, before demolishing the lobe pump, to communicate all the data carried on the nameplates and relating to the components that will be demolished to the relative manufacturers.

The LPDPG is made with materials that are not subject to specific obligations for toxicity and / or harmfulness and therefore do not require particular disposal procedures, except for the oils present (with reference to section 5.6); substances that must be disposed of in compliance with the legislative obligations in force, as indicated in the relative safety sheet, with reference to sections 5.7, 5.8.



WARNING

The LPDPG presents some substances that must be disposed of in compliance with the legislative obligations in force.

DO NOT DISPOSE OF THESE MATERIALS IN THE ENVIRONMENT

In case of demolition, the user, in accordance with the local law regulations, must take special precautions regarding the disposal of significant materials from the environmental point of view, such as:

- ⚠ plastic materials of pneumatic pipes (when present)
- ⚠ coated electric cables (when present)
- ⚠ any remaining toxic or corrosive substances
- ⚠ Lubricant oil of the gear box.

CHAPTER 7: SPARE PARTS

Throughout his life, the LPDPG may require the replacement of consumed or worn parts. To simplify the recognition of its consumption elements, O.M.A.C. S.r.l. completes this manual with specifications defined for the identification of spare parts. They are mainly spare parts that, if required, must be replaced only by skilled technical personnel authorised by O.M.A.C.



WARNING

Only skilled personnel authorised by O.M.A.C. S.r.l. can carry out extraordinary maintenance replacement interventions, performing the replacement interventions of the components described below.

Do not try to replace parts without authorisation.

In case of replacing constructive mechanical parts that compose the LPDPG, some of these need long manufacture time that can take a few months. It is advisable to have enough of the components described above in the amounts deemed necessary to limit machine down time.



DANGER

Only skilled personnel authorised by O.M.A.C. s.r.l. can carry out extraordinary maintenance interventions; do not try to replace parts of the machine if unauthorised. O.M.A.C. s.r.l. is not liable for damages to persons, animals or things deriving from unauthorised interventions.

7.1 List of spare parts and section drawings of the lobe displacement pump

Below the LPDPG will be presented in its various sizes, complete with exploded view construction drawing and bill of materials table.

For each component, the tables below indicate the position in the exploded view drawing, the description, the needed amount and, depending on the model, the item code to order as spare part.

In the "amounts" column there may be one or more values present: where there are two amounts, the value marked with the asterisk only refers to the code marked with an asterisk, present on the same line, with reference to the pump model that one possesses.



WARNING

If, to replace spare parts, one needs to remove the front cover of the pump (pos. 44), it is essential to restore the pump hygiene level before putting it back into service. It is reminded that in case the LPDPG has been configured for the treatment of alimentary products, level 3 hygiene must be ensured.

7.1.1 BA BB BF Size 100: Spare parts list

7.1.1.1 Pump exploded view drawing

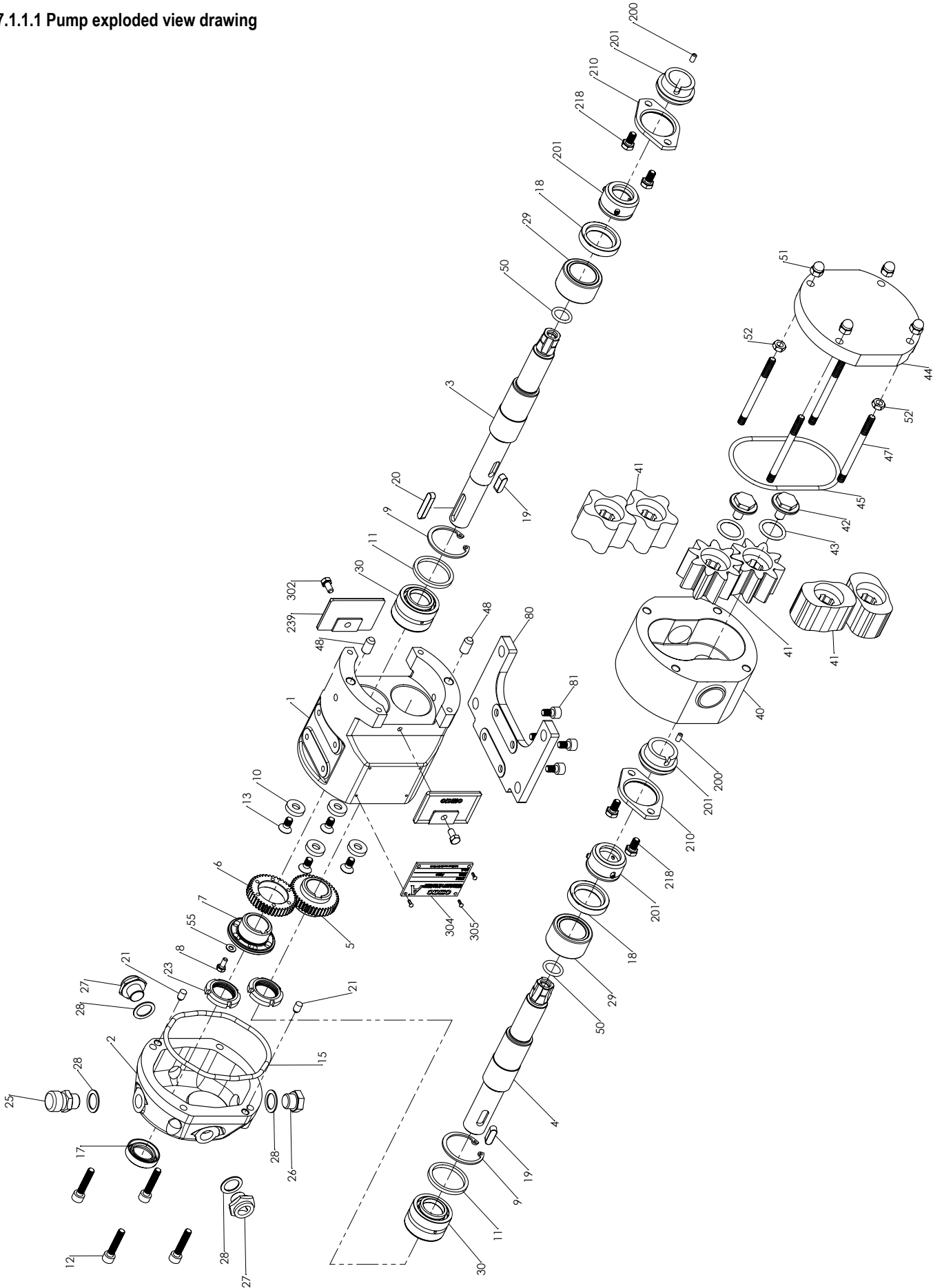

7.1.1.2 Spare parts names and codes

Pos.	Descriptions	Q.ty	BA100	BB100	BF100
1	Bearing Housing G25	1	2001G010		2001A006
2	Gear cover	1	2001L030		2001A030
3	Standard driving shaft	1	2004B400		
4	Standard driven shaft	1	2004B428		
5	Fixed gear	1	2008M013		
6	Adjustable gear	1	2008M017		
7	Adjustable gear bush	1	2008M038		
8	Scew	6	410F04x10		
9	Split ring	2	421F37I		
10	Plane washer	4	412F06G17		
11	Axial adjustment spacer	2	2014M030		
12	Screw	4	411A06x35		
13	Screw	4	411F06x12Z		
15	Gear cover seal	1	404T3350		
17	Oil seal ring	1	403Y18307D		
18	Oil seal ring	2	403Y25377D		
19	Key	2	418F06x18		
20	Key	1	418A06x30		
23	Gear ring nut	2	415F20AUT		
25	Oil cap vent	1	407L14S		407P14S
26	Oil cap	1	407L14T		407P14T
27	Oil level	1	407L14L		407P14L
29	Front bearing	2	2019M020		
30	Rear bearing	2	406FNATB5904		
40	Rotorcase	1	23 B50	23 B50B	23 B50
41	316 S.S. gear rotor ST	2	2005B086L1	2005B086	2005B086L1
41	316 S.S. 2 lobe ST	2	2005B089L1	2005B089	2005B089L1
41	S.S. anti-seizure alloy gear rotor	2	2005&086L	2005&086	2005&086L
41	S.S. anti-seizure alloy 2 lobe	2	2005&089L	2005&089	2005&089L
42	Locking nut for rotor	2	2004B107L1	2004B107	2004B107L1
43	O-ring	2	404U30753A	404T3075	
44	Rotorcase cover	1	2006B022L1	2006B022	2006B022L1
45	Cover O-ring	1	404U63123A	404T6312	404T6312
47	Stud	4	419A06X80		
48	Pin	2	417A08X16		
50	O-ring	2	404U20503A	404T2050	404T2050
51	Cap nut	4	414A06		
52	Nut	2	413A06		
55	Plane washer	6	412F04		
56	Mech.saf.valve support	1	2013L015		
57	Mech.saf.valve piston	1	2013B059		
58	Mech.saf.valve cover	1	2013L018		
59	Mech.saf.valve adjustment screw	1	2013B058		
60	Mech.saf.valve thrust washer	1	2013L017		
61	Mech.saf.v. adjustment ring nut	1	2013A021		
62	Mech.saf.valve retainer	1	2013L020		
63	Mech.saf.valve screw	4	411A06X55		
65	Mech.saf.valve screw	2	420A05X06		
66	Mech.saf.valve split ring	1	421A025I		
67	Mech.saf.valve split ring	1	421A010E		

Pos.	Descriptions	Q.ty	BA100	BB100	BF100
68	Mech.saf.valve o-ring	1		404T4118	
70	Mech.saf.valve lock	1		411A05X05	
71	Mech.saf.valve spring	1		See par.7.1.6	
72	Mech.saf.valve cover	1		2006B026	
80	Foot	1	2001G100		2001A100
81	Screw for foot	4		411A06X10	
111	End cover for heating version	1	2006B050L	2006B050	2006B050L
113	End cover jacket	1		2006B167	
114	Screw	4		411A06X16	
115	O-ring	1		404T176	
239	Seal protection	2		4034Y005	
302	Screw	2		410A05X10	
304	Name plate	1	4434A102	4434A103	4434A103
305	Rivet	4		44301027	

7.1.1.3 Seals section drawings and spare parts

Single mechanical seal 7KFO

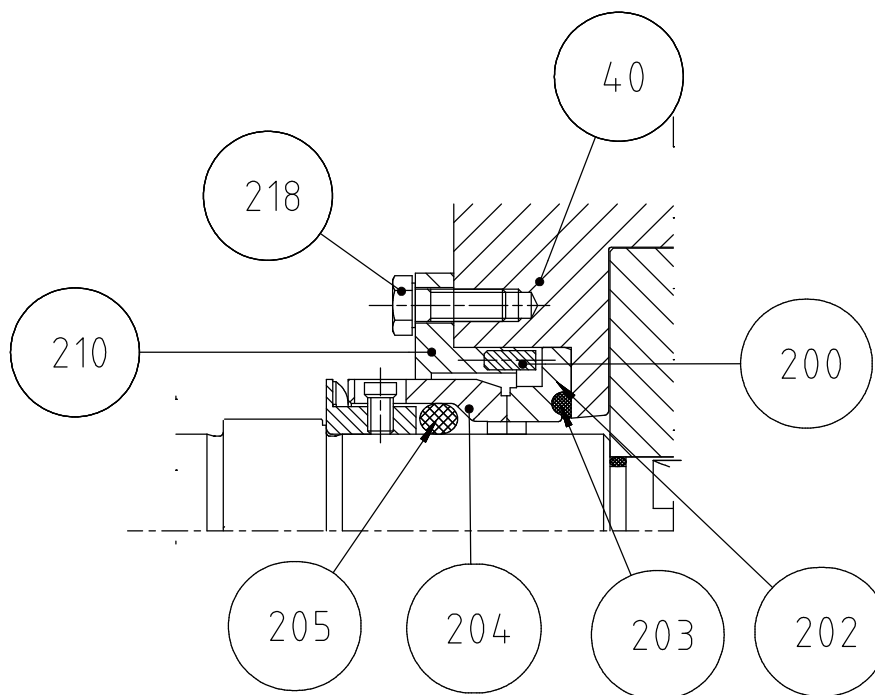

Pos.	Descriptions	Q.ty	BA100	BB100	BF100
200	Seal stop pin	2		430A02X08	
201	Mechanical seal 7KFO (pos.202+203+204+205)	2		4U0217KFO...	
202	Mech. Seal Stationary part	2			
203	Stationary part o-ring	2	404U40873A	404U4087	404U4087
204	Mech. Seal Rotating part	2			
205	Rotating part o-ring	2	404U40873A	404U4087	404U4087
210	Balancing ring	2		2014B030	
218	Balancing ring screw	4		410A06X16	

Pos.201 = (202+203+204+205)

7.1.2 BA BB BF Size 105 B110 B115: Spare parts list

7.1.2.1 Pump exploded view drawing

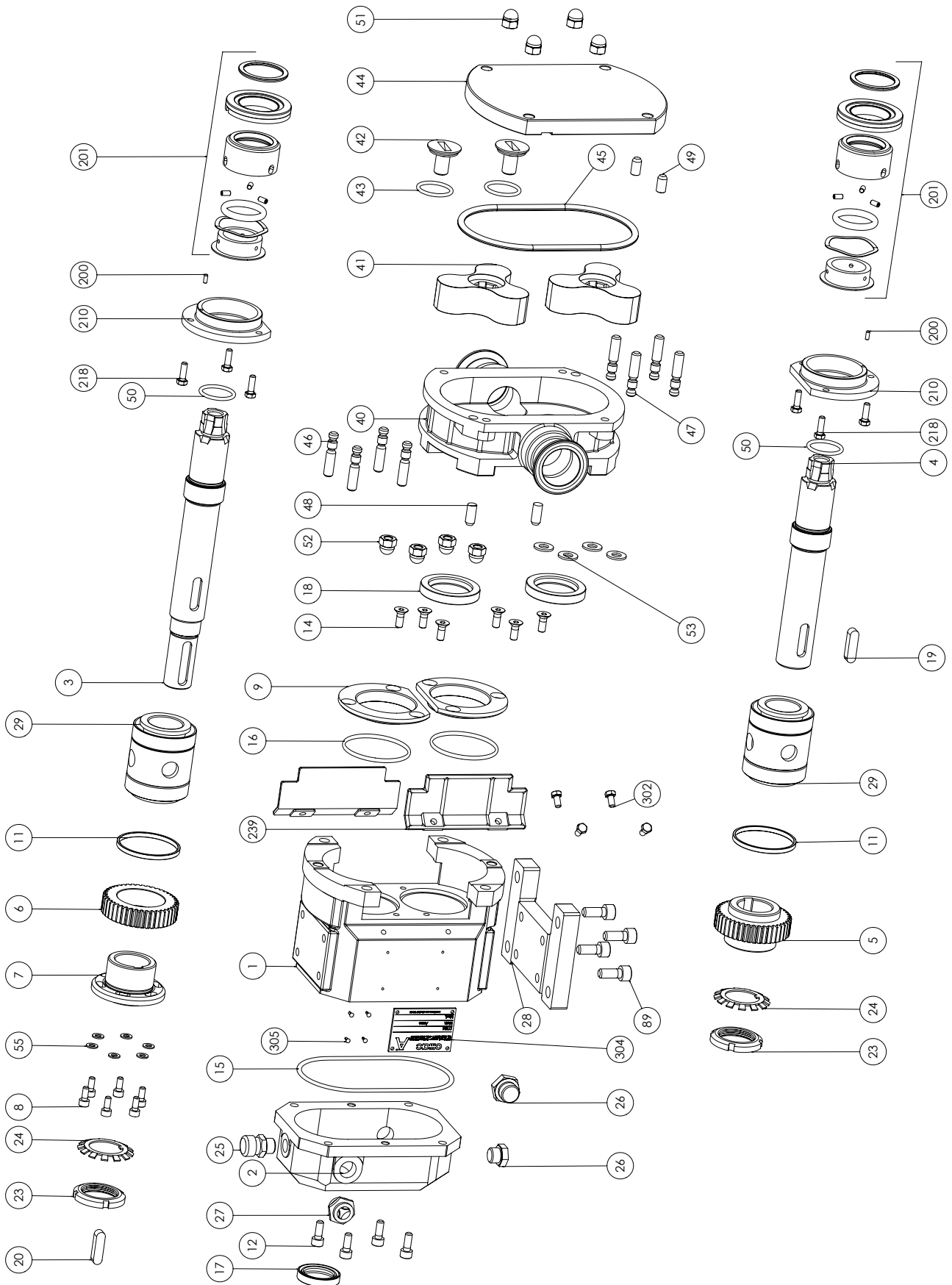

7.1.2.2 Spare parts names and codes

Pos.	Descriptions	Q.ty	BF105	BF110	BF115	BA105	BA110	BA115	BB105	BB110	BB115
1	BEARING BOX	1		2001A001				2001G001			
2	GEARS COVER	1		2001A031				2001L031			
3	STANDARD DRIVING SHAFT	1	2004B401		2004B402	2004B401		2004B402	2004B401		2004B402
3	DUPLEX DRIVIGN SHAFT	1									
3	DOUBLE FLUSH. MEC. SEAL DRIVING SHAFT	1									
4	STANDARD DRIVEN SHAFT	1	2004B429		2004B430	2004B429		2004B430	2004B429		2004B430
4	DUPLEX DRIVEN SHAFT	1									
4	DOUBLE FLUSH. MEC. SEAL DRIVEN SHAFT	1									
5	FIXED GEAR	1				2008M001					
6	ADJUSTABLE GEAR	1				2008M007					
7	ADJUSTABLE GEAR BUSH	1				2008M031					
8	SCREWS FOR ADJ. GEAR	6				411F05X14					
9	BEARING RETAINER	2				2001C051					
10	BEARING SPACER	2				-					
11	AXIAL ADJUSTMENT SPACER	2 8(1)				2014M024					
12	SCREW	4 10(1)				411A06X16					
13	GEAR COVER PIN	2				417A06X15					
14	SCREW	6 8(2)				411A06X16S					
15	GEAR COVER O-RING	1		404T4450				404T4437			
16	BEARING RETAINER O'RING	2				404T3218					
17	OIL SEAL RING	1				403Y26377D					
18	OIL SEAL RING	2				403Y35527D					
19	KEY	2				418F08X30M					
20	KEY	1				418F08X40					
21	BEARING RING NUT	2				-					
22	WASHER	2				-					
23	GEAR RING NUT	2				415F30					
24	WASHER	2				416F30					
25	OIL VENT CAP	1		407P14S				407L14S			
26	OIL CAP	2		407P14T + 407P38T				407L14T + 407L38T			
27	OIL LEVEL	1		407P38L				407L38L			
28	FOOT	1				2001G101					
29	ASSEMBLED FRONT BEARING	2				2019M001					
30	ASSEMBLED REAR BEARING	2				-					

Pos.	Descriptions	Q.ty	BF105	BF110	BF115	BA105	BA110	BA115	BB105	BB110	BB115
31	VERTICAL FOOT	2					2001A301				
32	SCREW	8	411A08X20	411A08X20	411A08X20	411A08X20	411A08X20	411A08X20	411A08X20	411A08X20	411A08X20
33	COUNTERFLANGE FOR ENLARGED INLET PORT	1	-	-	2006B045	-	-	2006B045	-	-	2006B045
34	COUNTERFLANGE O-RING	1	-	-	404T3281	-	-	404U32813A	-	-	404T3281
40	ROTORCASE (see separate list)	1	23.....21	23.....22	23.....23	23...51	23...52	23...53	23...51B	23...52B	23...53B
41	316 STAINLESS STEEL 3 LOBE ST	2	-	2005B111L	2005B112L	-	2005B111L	2005B112L	-	2005B111	2005B112
41	316 STAINLESS STEEL 2 LOBE ST	2	-	2005B121L	2005B122L	-	2005B121L	2005B122L	-	2005B121	2005B122
41	316 STAINLESS STEEL 3 LOBE SM	2	-	-	-	-	-	-	-	-	-
41	316 STAINLESS STEEL 2 LOBE SM	2	-	-	-	-	-	-	-	-	-
41	RUBBER COATED 316 S.S. 3 (5) LOBE	2	-	-	-	-	-	-	-	2005B151	2005B152
41	RUBBER COATED 316 S.S. 2 LOBE	2	-	-	-	-	-	-	-	2005B162	2005B160
41	ANTI-SEIZURE ALLOY DUAL WING ROT. PISTON	2	2005&140L	2005&141L	2005&142L	2005&140L	2005&141L	2005&142L	2005&140	2005&141	2005&142
41	ANTI-SEIZURE ALLOY 3 LOBE	2	-	-	-	-	-	-	-	-	-
41	316 STAINLESS STEEL GEAR ROTOR	2	-	-	-	-	-	-	-	-	-
41	ANTI-SEIZURE ALLOY GEAR ROTOR	2	-	-	-	-	-	-	-	-	-
42	LOCKING NUT for STANDARD ROTOR	2		2004B121L			2004B121L			2004B121	
43	LOCKING NUT O-RING	2		404T4100			404U41003A			404T4100	
44	STANDARD FRONT COVER	1	2006B200L	2006B201L	2006B201L	2006B200L	2006B201L	2006B201L	2006B200	2006B201	2006B201
45	COVER O-RING	1	404T2013A	404T2063A	404T2063A	404U2013A	404U2063A	404U2063A	404T201	404T206	404T206
46	BACK STUD	4		419A08X33			419A08X31			419A08X31	
47	FRONT STUD	8-4(2)12(1)		419A08X33			419A08X31			419A08X31	
48	BACK PIN	2					417A08X20				
49	FRONT PIN	2					417A08X16				
50	O-RING	2		404T2075			404U20753A				404T2075
51	CAP NUT	8-4(2)12(1)					414A08				
52	CAP NUT	4					414A08				
53	PLANE WASHER	4					412A08				
54	PLANE WASHER	12					-				
55	PLANE WASHER	6					412F05				
	COMPLETE MECHANICAL SAFETY VALVE										
56/1	MECH.SAF.VALVE SUPPORT	1									
56	MECH.SAF.VALVE BUSH	1									
57	MECH.SAF.VALVE PISTON	1									

Pos.	Descriptions	Q.ty	BF105	BF110	BF115	BA105	BA110	BA115	BB105	BB110	BB115
58	MECH.SAF.VALVE COVER	1									
59	MECH.SAF.VALVE ADJUSTEMENT SCREW	1									
60	MECH.SAF.VALVE THRUST WASHER	1									
61	MECH.SAF.VALVE ADJUSTMENT RING NUT	1									
62	MECH. SAFETY VALVE ADJUST. RETAINER	1									
63	SUPPORT SCREW	4-6(1)									
64	SCREW	4									
65	SECURITY DOWEL	2									
66	SPLIT RING	1									
67	SPLIT RING	1									
68	O-RING	1									
69	O-RING	1									
70	LOCK BY-PASS PISTON	1									
71	SPRING	1									
72	END COVER FOR BY PASS	1									
73	INSPECTION COVER	1									
74	COVER TCEI SCREW	4									
75	BEARING SUPPORT	2									
76	TCEI SCREW	8									
77	BACK BULL RING	2									
78	TCEI SCREW	8									
80	STUD	4-8(2)									
81	PLANE WASHER	4-8(2)									
82	CAP NUT	4-8(2)									
83	FLANGED PORT	2									
84	PORT O-RING	2									
85	STUD	8									
86	PLANE WASHER	8									
87	CAP NUT	8									
88	OIL CLOSE CAP	1									
89	SCREW	4									
91	PNEUMATIC SAFETY VALVE SUPPORT	1									
92	VTCEI SCREW/PNEUMATIC SAFETY VALVE	46(1)									

Pos.	Descriptions	Q.ty	BF105	BF110	BF115	BA105	BA110	BA115	BB105	BB110	BB115
93	SUPPORT O-RING PNEUMATIC SAFETY VALVE	1									
94	PNEUMATIC SAFETY VALVE PISTON	1									
95	PNEUMATIC SAFETY VALVE KEY	1									
96	PNEUMATIC SAFETY VALVE PISTON O-RING	1									
97	PNEUMATIC SAFETY VALVE ADJUST. RING NUT	1									
98	PNEUMATIC SAFETY VALVE SECURITY DOWEL	2									
99	PNEUMATIC SAFETY VALVE COVER	1									
100	PNEUMATIC SAF. VALVE BACK COVER O-RING	1									
101	PNEUMATIC SAF. VALVE FRONT COVER O-RING	1									
102	PNEUMATIC SAF. VALVE PISTON-COVER O-RING	1									
103	PNEUMATIC SAFETY VALVE JACKET	1									
104	PNEUMATIC SAFETY VALVE SCREW	4 6(1)									
105	PNEUMATIC SAFETY VALVE THRUST RING	1									
106	PNEUM. SAF. VAL. PISTON ROD-THRUST O-RING	1									
107	PNEUM. SAF. VAL. THRUST-JACKET O-RING	1									
108	PNEUMATIC SAFETY VALVE RING NUT	2									
111	END COVER FOR HEATING VERSION	1									
112	END COVER FOR ASEPTIC VERSION	1									
113	END COVER JACKET	1									
114	TCEI SCREW	6									
115	END COVER JACKET O-RING	1									
116	INTERNAL COVER O-RING for ASEPTIC vers.	1									
117	EXTERNAL COVER O-RING for ASEPTIC vers.	1									
118	CONNECTION COUNTER FLANGE for AS vers.	2									
119	INTERNAL CONNECTION O-RING for AS vers.	2									
120	EXTERNAL CONNECTION O-RING for AS vers.	2									
121	SCREW	8									
302	SCREW	4					410A05X10				
303	PLUG	4					44301020				
304	NAME PLATE	1		44301026						44301026	
305	RIVET	4					44301027				
306	EYEBOLT	2									

7.1.2.3 Seals section drawings and spare parts

Single flushed mechanical seal 7KFO

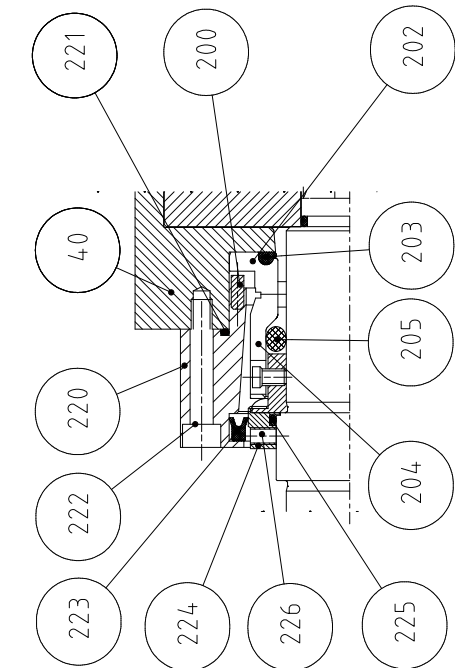

Single mechanical seal 7KFO

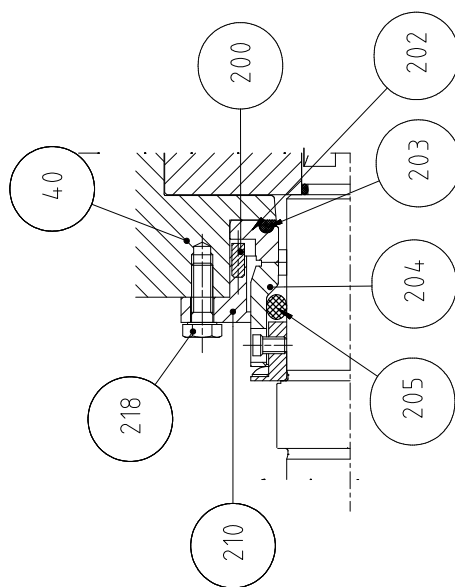

Pos.	Descriptions	Q.ty	BF105	BF110	BF115	BA105	BA110	BA115	BB105	BB110	BB115
200	Seal stop pin	2									
201	Mechanical seal 7KFO (pos.202+203+204+205)	2					430A03X08				
202	Mech. Seal Stationary part	2					4U0307KFO				
203	Stationary part o-ring	2									
204	Mech. Seal Rotating part	2									
205	Rotating part o-ring	2									
210	Balancing ring	2					2014B031				
218	Balancing ring screw	6					410A05X14				
220	Flushing seal box	2					2014B175				
221	O-ring	2					404U2224				
222	Screw	6					411A05X30				
223	Seal ring UM	2					402V57486				
224	Rotating Ring	2					2004B147				
225	Bush o-ring	2					404U2137				
226	Security dowel	6					420A04X05				

Pos.201 = (202+203+204+205)

7.1.3 BA BB BF Size 215 - 220: Spare parts list

7.1.3.1 Pump exploded view drawing

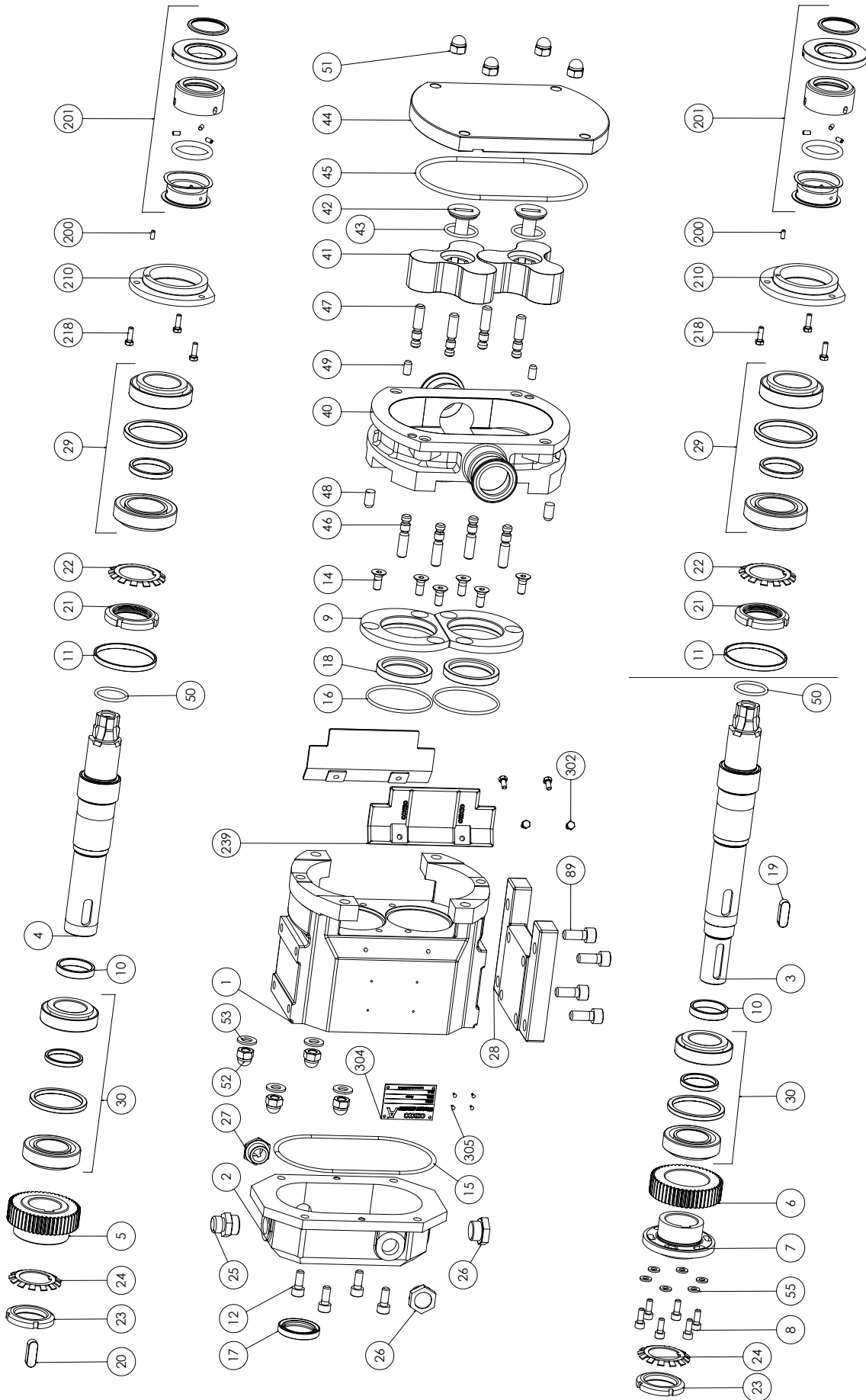

7.1.3.2 Spare parts names and codes

Pos.	Descriptions	Q.ty	BF215	BF220	BA215	BA220	BB215	BB220
1	BEARING BOX	1	2001A002		2001G002			
2	GEAR COVER	1	2001A032		2001L032			
3	STANDARD DRIVING SHAFT	1	2004B403	2004B404	2004B403	2004B404	2004B403	2004B404
3	DUPLEX DRIVIGN SHAFT	1						
3	DOUBLE FLUSH. MEC. SEAL DRIVING SHAFT	1						
4	STANDARD DRIVEN SHAFT	1	2004B431	2004B432	2004B431	2004B432	2004B431	2004B432
4	DUPLEX DRIVEN SHAFT	1						
4	DOUBLE FLUSH. MEC. SEAL DRIVEN SHAFT	1						
5	FIXED GEAR	1	2008M002					
6	ADJUSTABLE GEAR	1	2008M008					
7	ADJUSTABLE GEAR BUSH	1	2008M032					
8	SCREW	6	411F06X16					
9	BEARING RETAINER	2	2001C052					
10	BEARING SPACER	2	2014M021					
11	AXIAL ADJUSTMENT SPACER	2	2014M025					
12	SCREW	4	411A08X20S					
13	GEAR COVER PIN	2	417A06X14		417A6X15			
14	SCREW	6	411A08X20S					
15	GEAR COVER O-RING	1	404T4537		404T4562			
16	BEARING RETAINER O-RING	2	404T3268					
17	OIL SEAL RING	1	403Y32457					
18	OIL SEAL RING	2	403Y45608D					
19	KEY	2	418F10X30M					
20	KEY	1	418F08X40					
21	BEARING RING NUT	2	415F40					
22	WASHER	2	416F40					
23	GEAR RING NUT	2	415F35					
24	WASHER	2	416F35					
25	OIL VENT CAP	1	407P12S		407L12S			
26	OIL CAP	2	407P12T		407L12T			
27	OIL LEVEL	1	407P12L		407L12L			
28	FOOT	1	2001G102					
29	ASSEMBLED FRONT BEARING	2	2019M002					
30	ASSEMBLED REAR BEARING	2	2019M005					
31	VERTICAL FOOT	2	2001A302					
32	SCREW	8	411A10X20					
33	COUNTERFLANGE FOR ENLARGED INLET PORT	1		2006B046		2006B046		2006B046
34	O-RING	1		404U4350		404U43503A		404U4350
40	ROTOR CASE (see separate list)	1	23 . . . 24	23 . . . 25	23 . . 54	23 . . 55	23 . . 54B	23 . . 55B
41	316 STAINLESS STEEL 3 LOBE ST	2	2005B113L	2005B114L	2005B113L	2005B114L	2005B113	2005B114
41	316 STAINLESS STEEL 2 LOBE ST	2					2005B123	2005B124
41	316 STAINLESS STEEL 3 LOBE SM	2						
41	316 STAINLESS STEEL 2 LOBE SM	2						
41	RUBBER COATED 316 S.S. 3 (5)^ LOBE	2						
41	RUBBER COATED 316 S.S. 2 LOBE	2						
41	ANTI-SEIZURE ALLOY DUAL WING ROT. PISTON	2					2005&143	2005&144
41	ANTI-SEIZURE ALLOY 3 LOBE	2						
41	316 STAINLESS STEEL GEAR ROTOR	2						
41	ANTI-SEIZURE ALLOY GEAR ROTOR	2						
42	LOCKING NUT for STANDARD ROTOR	2	2004B122L		2004B122L		2004B122	

Pos.	Descriptions	Q.ty	BF215	BF220	BA215	BA220	BB215	BB220
43	O'RING	2	404T4118		404U41183A		404T4118	
44	STANDARD FRONT COVER	1	2006B202L		2006B202L		2006B202	
45	COVER O'RING	1	404T4625		404U66003A		404T6600	
46	BACK STUD	4	419A10X39					
47	FRONT STUD	8-4(2)	419A10X39					
48	BACK PIN	2	417A10X20					
49	FRONT PIN	2	417A08X16					
50	O'RING	2	404T2093		404U20933A		404T2093	
51	CAP NUT	8-4(2)	414A10					
52	CAP NUT	4	414A10					
53	PLANE WASHER	4	412A10					
54	PLANE WASHER	12	-					
55	PLANE WASHER	6	412F06					
56/1	BY PASS - COMPLETE RELIEF VALVE	1						
56	BY PASS SUPPORT	1						
57	BY PASS PISTON	1						
58	BY PASS COVER	1						
59	BY PASS ADJUSTEMENT SCREW	1						
60	THRUST WASHER	1						
61	ADJUSTMENT RING NUT	1						
62	BY PASS ADJUSTEMENT RETAINER	1						
63	SCREW	4-6(1)						
64	SCREW	4						
65	SCREW	2						
66	SPLIT RING	1						
67	SPLIT RING	1						
68	O-RING	1						
69	O-RING	1						
70	LOCK BY-PASS PISTON	1						
71	SPRING	1						
72	END COVER FOR BY PASS	1						
73	INSPECTION COVER	1						
74	TCEI SCREW	4						
75	BEARING SUPPORT	2						
76	TCEI SCREW	8						
77	BACK BULL RING	2						
78	TCEI SCREW	8						
80	STUD	4-8(2)						
81	PLANE WASHER	4-8(2)						
82	CAP NUT	4-8(2)						
83	FLANGED PORT	2						
84	PORT O-RING	2						
85	STUD	8						
86	PLANE WASHER	8						
87	CAP NUT	8						
88	OIL CLOSE CAP	1						
89	SCREW	4						
91	PNEUMATIC BY PASS SUPPORT	1						
92	VTCEI SCREW	6						
93	SUPPORT O'RING	1						

Pos.	Descriptions	Q.ty	BF215	BF220	BA215	BA220	BB215	BB220
94	PNEUMATIC BY-PASS PISTON	1						
93+94	PNEUMATIC BY-PASS PISTON+O-RING	1						
95	KEY	1						
96	PISTON O'RING	1						
97	ADJUSTMENT RING NUT	1						
98	SCREW	2						
99	PNEUMATIC BY PASS COVER	1						
100	BACK COVER O-RING	1						
101	FRONT COVER O-RING	1						
102	PISTON-COVER O-RING	1						
103	PNEUMATIC BY PASS JACKET	1						
104	SCREW	6						
105	THRUST RING	1						
106	PISTON ROD-THRUST O-RING	1						
107	THRUST-JACKET O-RING	1						
108	RING NUT	2						
111	END COVER FOR HEATING VERSION	1						
112	END COVER FOR ASEPTIC VERSION	1						
113	END COVER JACKET	1						
114	TCEI SCREW	6						
115	END COVER JACKET O'RING	1						
116	INTERNAL COVER O'RING for ASEPTIC vers.	1						
117	EXTERNAL COVER O'RING for ASEPTIC vers.	1						
118	CONNECTION COUNTER FLANGE for AS.vers.	2						
119	INTERNAL CONNECTION O'RING for AS.vers.	2						
120	EXTERNAL CONNECTION O'RING for AS.vers.	2						
121	SCREW	8						
239	SEALS PROTECTION	2			4034Y002			
302	SCREW	4			410A05X10			
303	PLUG	4			44301022			
304	NAME PLATE	1	4434A102		4434A103			4434A102
305	RIVET	4			44301027			
306	EYEBOLT	2			-			

7.1.3.3 Seals section drawings and spare parts

Single mechanical seal 7KFO

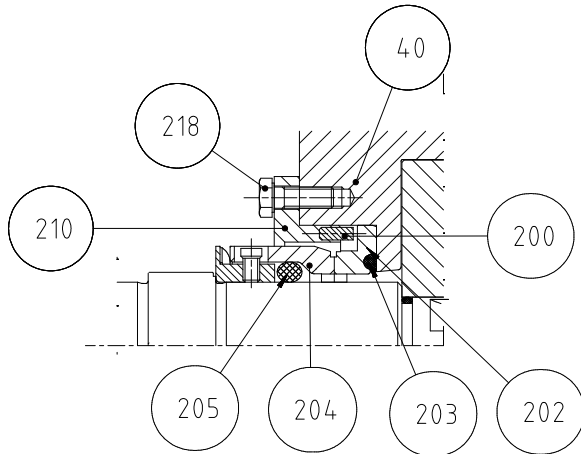

Single flushed mechanical seal 7KFO

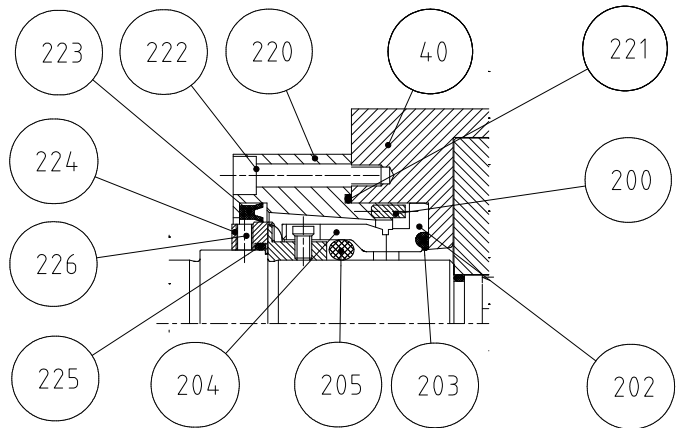

Pos.	Descriptions	Q.ty	BF215	BF220	BA215	BA220	BB215	BB220
200	Seal stop pin	2	430A04X10					
201	Mechanical seal 7KFO (pos.202+203+204+205)	2	4U0357KFO...					
202	Mech. Seal Stationary part	2						
203	Stationary part o-ring	2						
204	Mech. Seal Rotating part	2						
205	Rotating part o-ring	2						
210	Balancing ring	2			2014B032			
218	Balancing ring screw	6			410A06X16			
220	Flushing seal box	2			2014B176			
221	O-ring	2			404U3256			
222	Screw	6			411A06X35			
223	Seal ring UM	2			402V70578			
224	Rotating Ring	2			2004B148			
225	Bush o-ring	2			404U3181			
226	Security dowel	6			420A05X05			

Pos.201 = (202+203+204+205)

7.1.4 BA BB BF Size 325 - 330 - 390: Spare parts list

7.1.4.1 Pump exploded view drawing

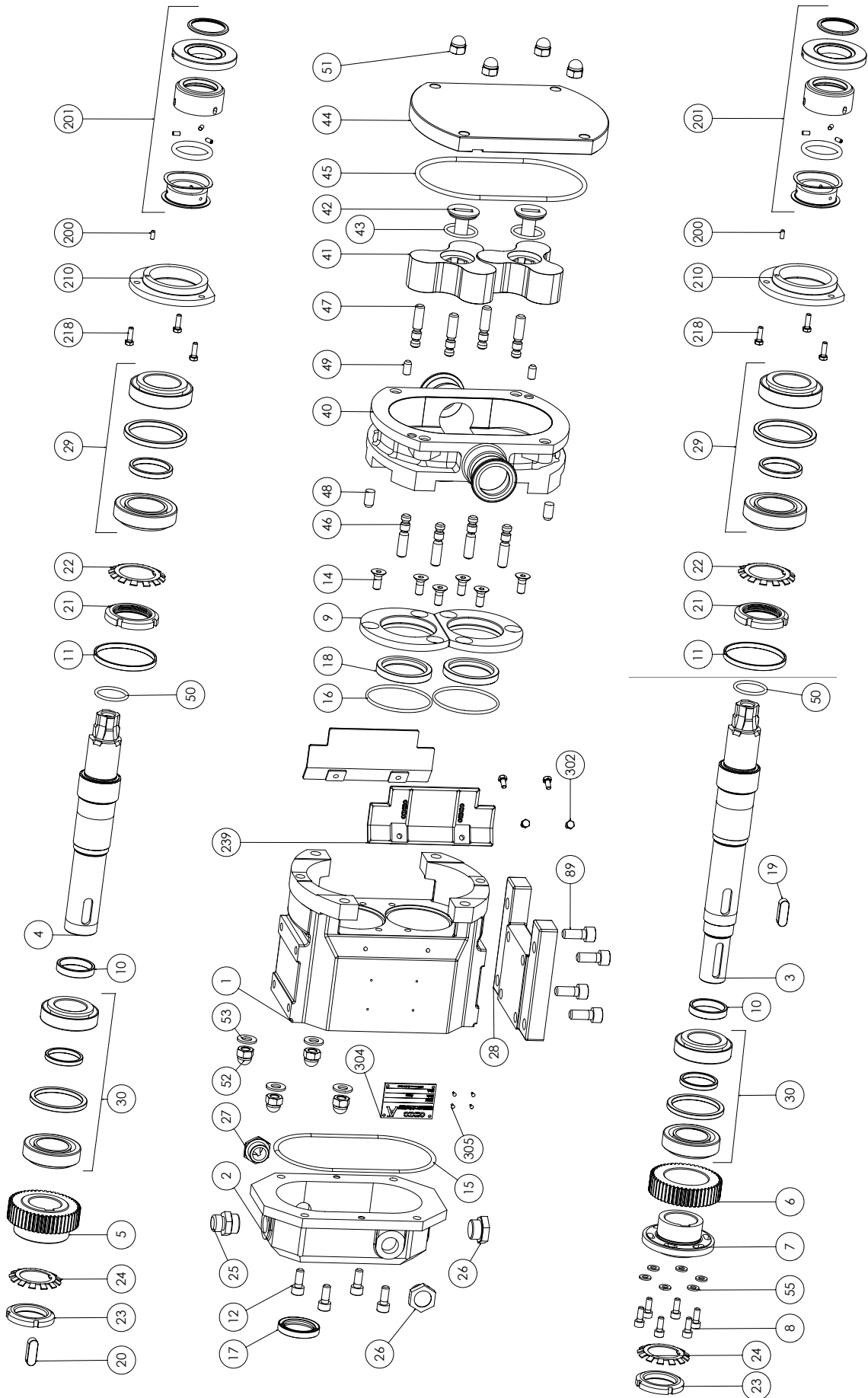

7.1.4.2 Spare parts names and codes

Pos.	Descriptions	Q.ty	BF325	BF330	BA325	BA330	BA390	BB325	BB330	BB390
1	BEARING BOX	1	2001A003				2001G003			
2	GEAR COVER	1	2001A033				2001L033			
3	STANDARD DRIVING SHAFT	1	2005B405	2004B406	2004B405	2004B406	2004B406	2004B405	2004B406	2004B406
3	DUPLEX DRIVIGN SHAFT	1								
3	DOUBLE FLUSH. MEC. SEAL DRIVING SHAFT	1								
4	STANDARD DRIVEN SHAFT	1	2004B433	2004B434	2004B433	2004B434	2004B434	2004B433	2004B434	2004B434
4	DUPLEX DRIVEN SHAFT	1								
4	DOUBLE FLUSH. MEC. SEAL DRIVEN SHAFT	1								
5	FIXED GEAR	1					2008M003			
6	ADJUSTABLE GEAR	1					2008M009			
7	ADJUSTABLE GEAR BUSH	1					2008M033			
8	SCREW	6					411F08X20			
9	BEARING RETAINER	2					2001C053			
10	BEARING SPACER	2					-			
11	AXIAL ADJUSTMENT SPACER	2					2014M026			
12	SCREW	4					411A08X25			
13	GEAR COVER PIN	2	417A06X16						417A6X15	
14	SCREW	6 (6)					411A08X20S			
15	GEAR COVER O-RING	1	404T4650						404T4675	
16	BEARING RETAINER O'RING	2					404T4312			
17	OIL SEAL RING	1					403Y37528			
18	OIL SEAL RING	2					403Y60758D			
19	KEY	2					418F12X40M			
20	KEY	1					418F10X50			
21	BEARING RING NUT	2					415F50			
22	WASHER	2					416F50			
23	GEAR RING NUT	2					415F40			
24	WASHER	2					416F40			
25	OIL VENT CAP	1	407P12S						407L12S	
26	OIL CAP	2	407P12T						407L12T	
27	OIL LEVEL	1	407P12L						407L12L	
28	FOOT	1							2001G103	
29	ASSEMBLED FRONT BEARING	2							2019M003	
30	ASSEMBLED REAR BEARING	2							2019M002	

Pos.	Descriptions	Q.ty	BF325	BF330	BA325	BA330	BA390	BB325	BB330	BB390
31	VERTICAL FOOT	2				2001A303				
32	SCREW	8				411A12X25				
33	COUNTERFLANGE FOR ENLARGED INLET PORT	1		2006B047					2006B047	
34	O-RING	1		404T4500		404U45003A			404T4500	
40	ROTOR CASE (see separate list)	1	23.....26	23.....27	23...56	23...57	23...58	23...56B	23...57B	23...58B
41	316 STAINLESS STEEL 3 LOBE ST	2	2005B115L	2005B116L	2005B115L	2005B116L	2005B176L	2005B115	2005B116	2005B176
41	316 STAINLESS STEEL 3 LOBE SM	2								
41	316 STAINLESS STEEL 2 LOBE ST	2								
41	316 STAINLESS STEEL 2 LOBE SM	2								
41	316 S.STEEL. DUAL WING ROT. PIST ST	2								
41	316 S.STEEL. DUAL WING ROT. PIST SM	2								
41	ANTI-SEIZURE ALLOY DUAL WING ROT/PISTON	2						2005&145	2005&146	
41	ANTI-SEIZURE ALLOY 3 LOBE	2								
41	316 STAINLESS STEEL GEAR ROTOR	2								
41	ANTI-SEIZURE ALLOY GEAR ROTOR	2								
42	LOCKING NUT for STANDARD ROTOR	2	2004B123L		2004B123L		2004B126L		2004B123	2004B126
43	O'RING	2	404U4162			404U41623A			404U4162	
44	STANDARD FRONT COVER	1	2006B203L			2006B203L			2006B203	
45	COVER O-RING	1	404U6720			404U67203A			404U6720	
46	BACK STUD	4				419A12X46				
47	FRONT STUD	8-4(2)				419A10X39				
48	BACK PIN	2				417A12X25				
49	FRONT PIN	2				417A08X16				
50	O'RING	2	404U2137			404U21373A			404U2137	
51	CAP NUT	8-4(2)				414A10				
52	CAP NUT	4				414A12				
53	PLANE WASHER	4				412A12				
54	PLANE WASHER	12				-				
55	PLANE WASHER	6				412F08				
56	BY PASS - COMPLETE RELIEF VALVE	1								
57	BY PASS SUPPORT	1								
58	BY PASS PISTON	1								
58	BY PASS COVER	1								
59	BY PASS ADJUSTEMENT SCREW	1								

Pos.	Descriptions	Q.ty	BF325	BF330	BA325	BA330	BA390	BB325	BB330	BB390
60	THRUST WASHER	1								
61	ADJUSTMENT RING NUT	1								
62	BY PASS ADJUSTMENT RETAINER	1								
63	SCREW	4-6(1)								
64	SCREW	4								
65	SECURITY DOWEL	2								
66	SPLIT RING	1								
67	SPLIT RING	1								
68	O-RING	1								
69	O-RING	1								
70	LOCK BY-PASS PISTON	1								
71	SPRING	1								
72	END COVER FOR BY PASS	1								
73	INSPECTION COVER	1								
74	TCEI SCREW	4								
75	BEARING SUPPORT	2								
76	TCEI SCREW	8								
77	BACK BULL RING	2								
78	TCEI SCREW	8								
80	STUD	8								
81	PLANE WASHER	8								
82	CAP NUT	8								
83	FLANGED PORT	2								
84	PORT O'RING	2								
85	STUD	8								
86	PLANE WASHER	8								
87	CAP NUT	8								
88	OIL CLOSE CAP	1								
89	SCREW	4								
91	PNEUMATIC BY PASS SUPPORT	1								
92	VTCEI SCREW	6								
93	SUPPORT O-RING	1								
94	PISTONE BY-PASS PNEUMATICO	1								

325 330 390

Pos.	Descriptions	Q.ty	BF325	BF330	BA325	BA330	BA390	BB325	BB330	BB390
93+94	PNEUMATIC BY-PASS PISTON+O-RING	1								
95	KEY	1								
96	PISTON O-RING	1								
97	ADJUSTMENT RING NUT	1								
98	SECURITY DOWEL	2								
99	PNEUMATIC BY PASS COVER	1								
100	BACK COVER O-RING	1								
101	FRONT COVER O-RING	1								
102	PISTON-COVER O-RING	1								
103	PNEUMATIC BY PASS JACKET	1								
104	SCREW	6								
105	THRUST RING	1								
106	PISTON ROD-THRUST O-RING	1								
107	THRUST-JACKET O-RING	1								
108	RING NUT	2								
111	END COVER FOR HEATING VERSION	1								
112	END COVER FOR ASEPTIC VERSION	1								
113	END COVER JACKET	1								
114	TCEI SCREW	4								
115	END COVER JACKET O-RING	1								
116	INTERNAL COVER O-RING for ASEPTIC vers.	1								
117	EXTERNAL COVER O-RING for ASEPTIC vers.	1								
118	CONNECTION COUNTER FLANGE for AS.vers.	2								
119	INTERNAL CONNECTION O-RING for AS.vers.	2								
120	EXTERNAL CONNECTION O-RING for AS.vers.	2								
121	SCREW	8-12(3)								
239	SEALS PROTECTION	2	4034Y003			4034Y003			4034Y003	
302	SCREW	4					410A05X10			
303	PLUG	4					44301023			
304	NAME PLATE	1						4434A103		4434A102
305	RIVET	4								44301027
306	EYEBOLT	2								-

7.1.4.3 Seals section drawings and spare parts

Single mechanical seal 7KFO

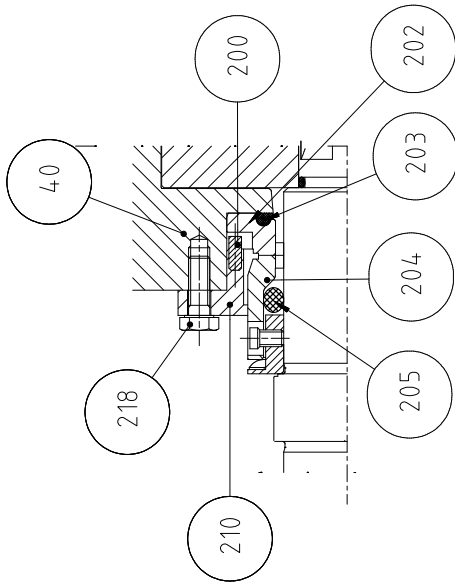

Single flushed mechanical seal 7KFO

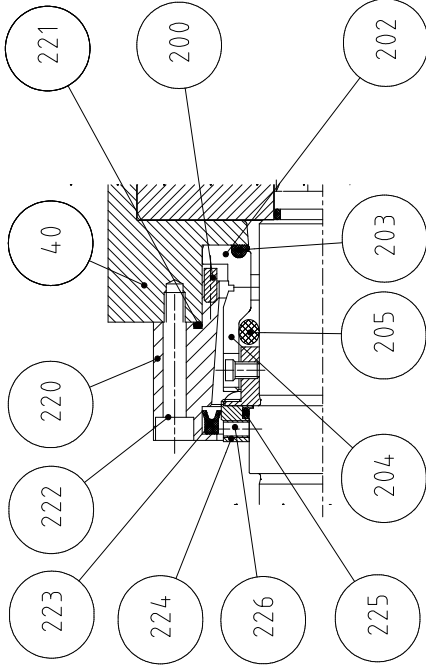

Pos.	Descriptions	Qty	BF325	BF330	BA325	BA330	BA390	BB325	BB330	BB390
200	Seal stop pin	2					430A04X10			
201	Mechanical seal 7KFO (pos.202+203+204+205)	2	4U0507KFO							
202	Mech. Seal Stationary part	2								
203	Stationary part o-ring	2								
204	Mech. Seal Rotating part	2								
205	Rotating part o-ring	2								
210	Balancing ring	2					2014B033			
218	Balancing ring screw	6					410A06X20			
220	Flushing seal box	2					2014B177			
221	O-ring	2					404U0840			
222	Screw	6					411A06X40			
223	Seal ring UM	2					402V85757			
224	Rotating Ring	2					2004B149			
225	Bush o-ring	2					404U4237			
226	Security dowel	6					420A05X06			

Pos.201 = (202+203+204+205)



7.1.5 BA BB Size 430 - 440: Spare parts list

7.1.5.1 Pump exploded view drawing

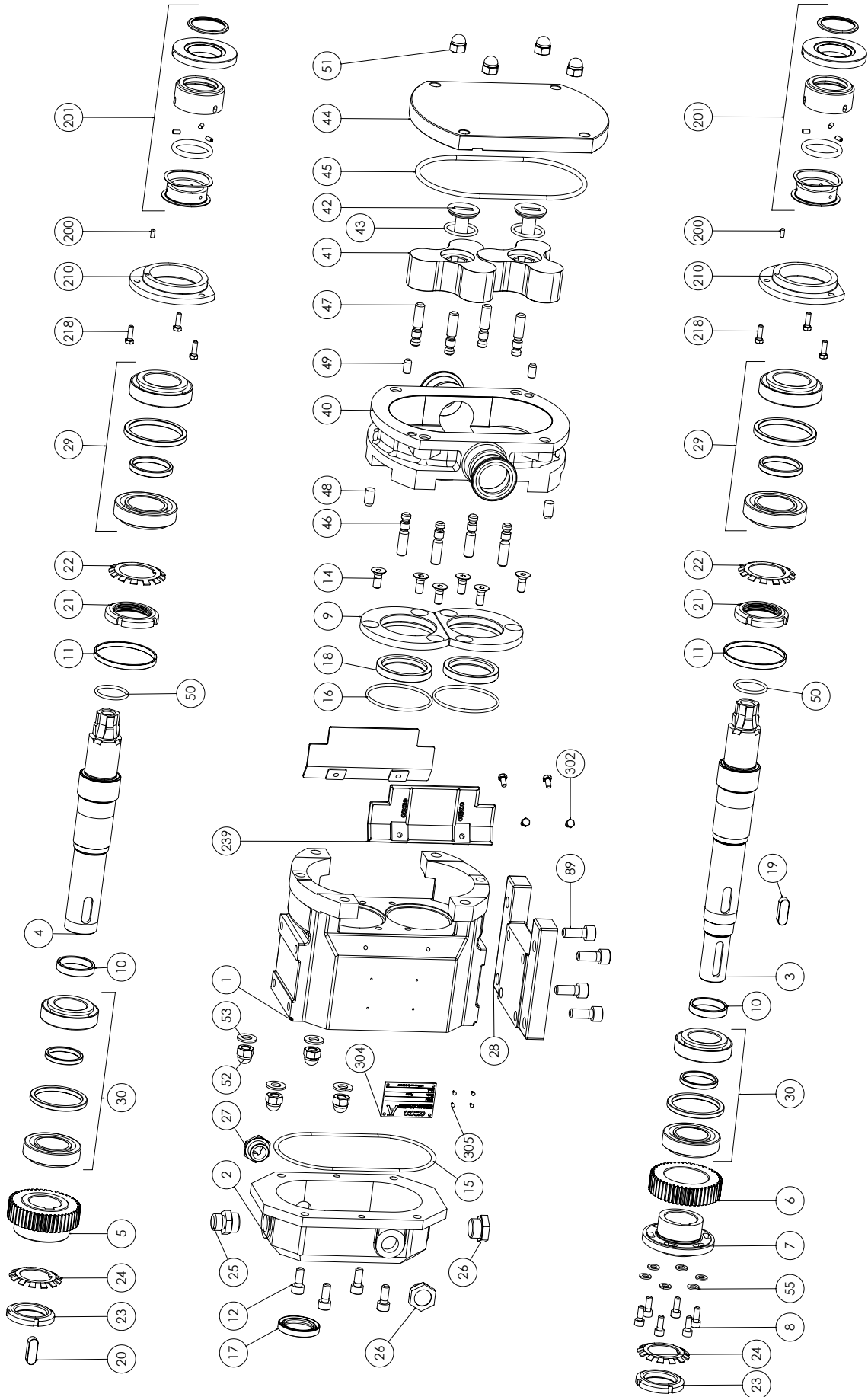

430 440

7.1.5.2 Spare parts names and codes

Pos.	Descriptions	Q.ty	BA430	BA440	BB430	BB440
1	BEARING HOUSING	1	2001G004			
2	GEAR COVER	1	2001L034			
3	STANDARD DRIVING SHAFT	1	2004B407	2004B408	2004B407	2004B408
3	DUPLEX DRIVIGN SHAFT	1				
3	DOUBLE FLUSH. MEC. SEAL DRIVING SHAFT	1				
4	STANDARD DRIVEN SHAFT	1	2004B435	2004B436	2004B435	2004B436
4	DUPLEX DRIVEN SHAFT	1				
4	DOUBLE FLUSH. MEC. SEAL DRIVEN SHAFT	1				
5	FIXED GEAR	1	2008M004			
6	ADJUSTABLE GEAR	1	2008M010			
7	ADJUSTABLE GEAR BUSH	1	2008M034			
8	SCREW	6	411F10X25			
9	BEARING RETAINER	2	2001C054			
10	BEARING SPACER	2	-			
11	AXIAL ADJUSTMENT SPACER	2	2014M027			
12	SCREW	4	411A10X30			
13	GEAR COVER PIN	2	417A6X15			
14	SCREW	8	411A10X25S			
15	GEAR COVER O-RING	1	404T4900			
16	BEARING RETAINER O-RING	2	404T4437			
17	OIL SEAL RING	1	403Y557210			
18	OIL SEAL RING	2	403Y801008			
19	KEY	2	418F18X50M			
20	KEY	1	418F14X70			
21	BEARING RING NUT	2	415F70			
22	WASHER	2	416F70			
23	GEAR RING NUT	2	415F60			
24	WASHER	2	416F60			
25	OIL VENT CAP	1	407L12S			
26	OIL CAP	2	407L12T			
27	OIL LEVEL	1	407L12L			
28	FOOT	1	2001G104			
29	ASSEMBLED FRONT BEARING	2	2019M004			
30	ASSEMBLED REAR BEARING	2	2019M007			
31	VERTICAL FOOT	2	2001A304			
32	SCREW	8	411A14X30			
33	COUNTERFLANGE FOR ENLARGED INLET PORT	1	-	2006B048	-	2006B048
34	O-RING	1	-	404U46503A	-	404T4650
40	ROTOR CASE (see separate list)	1	23...59	23...60	23...59B	23...60B
41	316 STAINLESS STEEL 3 LOBE ST	2	2005B117L	2005B118L	2005B117	2005B118
41	316 STAINLESS STEEL 3 LOBE SM	2				
41	316 STAINLESS STEEL 2 LOBE ST	2			2005B127	2005B128
41	316 STAINLESS STEEL 2 LOBE SM	2				
41	316 S.STEEL. DUAL WING ROT. PIST ST	2				2005B158
41	316 S.STEEL. DUAL WING ROT. PIST SM	2				
41	ANTI-SEIZURE ALLOY DUAL WING ROT.PISTON	2			2005&147	2005&148
41	ANTI-SEIZURE ALLOY 3 LOBE	2				
41	316 STAINLESS STEEL GEAR ROTOR	2				
41	ANTI-SEIZURE ALLOY GEAR ROTOR	2				
42	LOCKING NUT for STANDARD ROTOR	2	2004B124L		2004B124	

Pos.	Descriptions	Q.ty	BA430	BA440	BB430	BB440
43	O-RING	2	404U1583A		404T158	
44	STANDARD FRONT COVER	1	2006B204L		2006B204	
45	COVER O-RING	1	404U810003A		404T81000	
46	BACK STUD	4	419A16X55			
47	FRONT STUD	8	419A12X46			
48	BACK PIN	2	417A12X25			
49	FRONT PIN	2	417A08X16			
50	O-RING	2	404U31683A		404T3168	
51	CAP NUT	8	414A12			
52	CAP NUT	4	414A16			
53	PLANE WASHER	4	412A16			
54	PLANE WASHER	12	-			
55	PLANE WASHER	6	412F10			
56/1	BY PASS - COMPLETE RELIEF VALVE	1				
56	BY PASS SUPPORT	1				
57	BY PASS PISTON	1				
58	BY PASS COVER	1				
59	BY PASS ADJUSTEMENT SCREW	1				
60	THRUST WASHER	1				
61	ADJUSTMENT RING NUT	1				
62	BY PASS ADJUSTEMENT RETAINER	1				
63	SCREW	6				
64	SCREW	4				
65	SECURITY DOWEL	2				
66	SPLIT RING	1				
67	SPLIT RING	1				
68	O-RING	1				
69	O-RING	1				
71	SPRING	1				
72	END COVER FOR BY PASS	1				
89	SCREW	4				
91	PNEUMATIC BY PASS SUPPORT	1				
92	VTCEI SCREW	6				
93	SUPPORT O-RING	1				
94	PISTONE BY-PASS PNEUMATICO	1				
93+94	PNEUMATIC BY-PASS PISTON+O-RING	1				
95	KEY	1				
96	PISTON O-RING	1				
97	ADJUSTMENT RING NUT	1				
98	SECURITY DOWEL	2				
99	PNEUMATIC BY PASS COVER	1				
100	BACK COVER O-RING	1				
101	FRONT COVER O-RING	1				
102	PISTON-COVER O-RING	1				
103	PNEUMATIC BY PASS JACKET	1				
104	SCREW	6				
105	THRUST RING	1				
106	PISTON ROD-THRUST O-RING	1				
107	THRUST-JACKET O-RING	1				
108	RING NUT	2				

Pos.	Descriptions	Q.ty	BA430	BA440	BB430	BB440
111	END COVER FOR HEATING VERSION	1				
112	END COVER FOR ASEPTIC VERSION	1				
113	END COVER JACKET	1				
114	TCEI SCREW	4				
115	END COVER JACKET O'RING	1				
116	INTERNAL COVER O'RING for ASEPTIC vers.	1				
117	EXTERNAL COVER O'RING for ASEPTIC vers.	1				
118	CONNECTION COUNTER FLANGE for AS.vers.	2				
119	INTERNAL CONNECTION O'RING for AS.vers.	2				
121	SCREW	8				
239	SEALS PROTECTION	2		4034Y004		
302	SCREW	4		410A05X10		
303	PLUG	4		44301024		
304	NAME PLATE	1	4434A103		4434A102	
305	RIVET	4		44301027		
306	EYEBOLT	2	-			-

7.1.5.3 Seals section drawings and spare parts

Single mechanical seal 7KFO

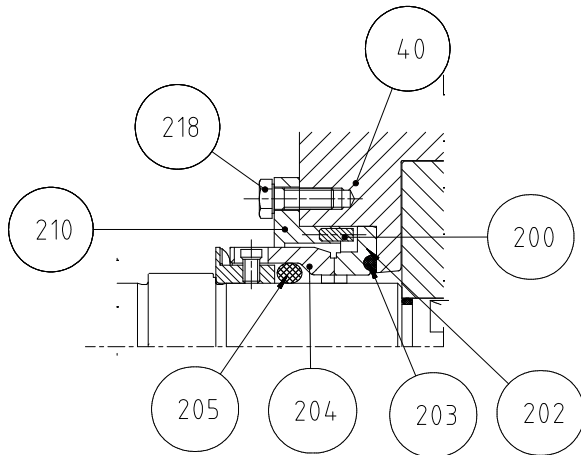

Single flushed mechanical seal 7KFO

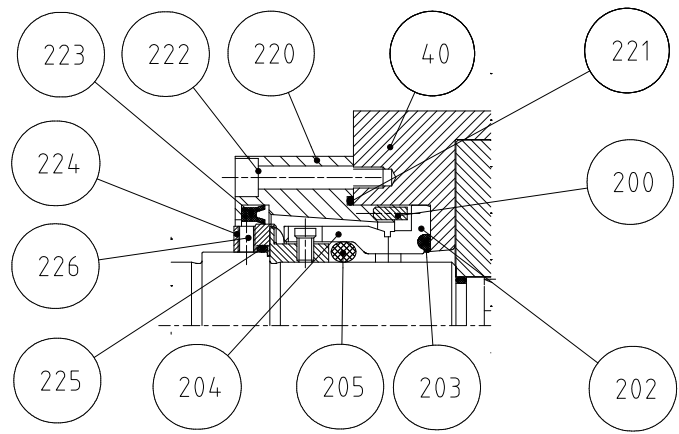

Pos.	Descriptions	Q.ty	BA430	BA440	BB430	BB440
200	Seal stop pin	2		430A04X10		
201	Mechanical seal 7KFO (pos.202+203+204+205)	2		4U0657KFO...		
202	Mech. Seal Stationary part	2				
203	Stationary part o-ring	2				
204	Mech. Seal Rotating part	2				
205	Rotating part o-ring	2				
210	Balancing ring	2		2014B034		
218	Balancing ring screw	6		410A10X20		
220	Flushing seal box	2				
221	O-ring	2				
222	Screw	6				
223	Seal ring UM	2				
224	Rotating Ring	2				
225	Bush o-ring	2				
226	Security dowel	6				

Pos.201 = (202+203+204+205)

7.1.6 BA BB Size 470 - 490: Spare parts list

7.1.6.1 Pump exploded view drawing

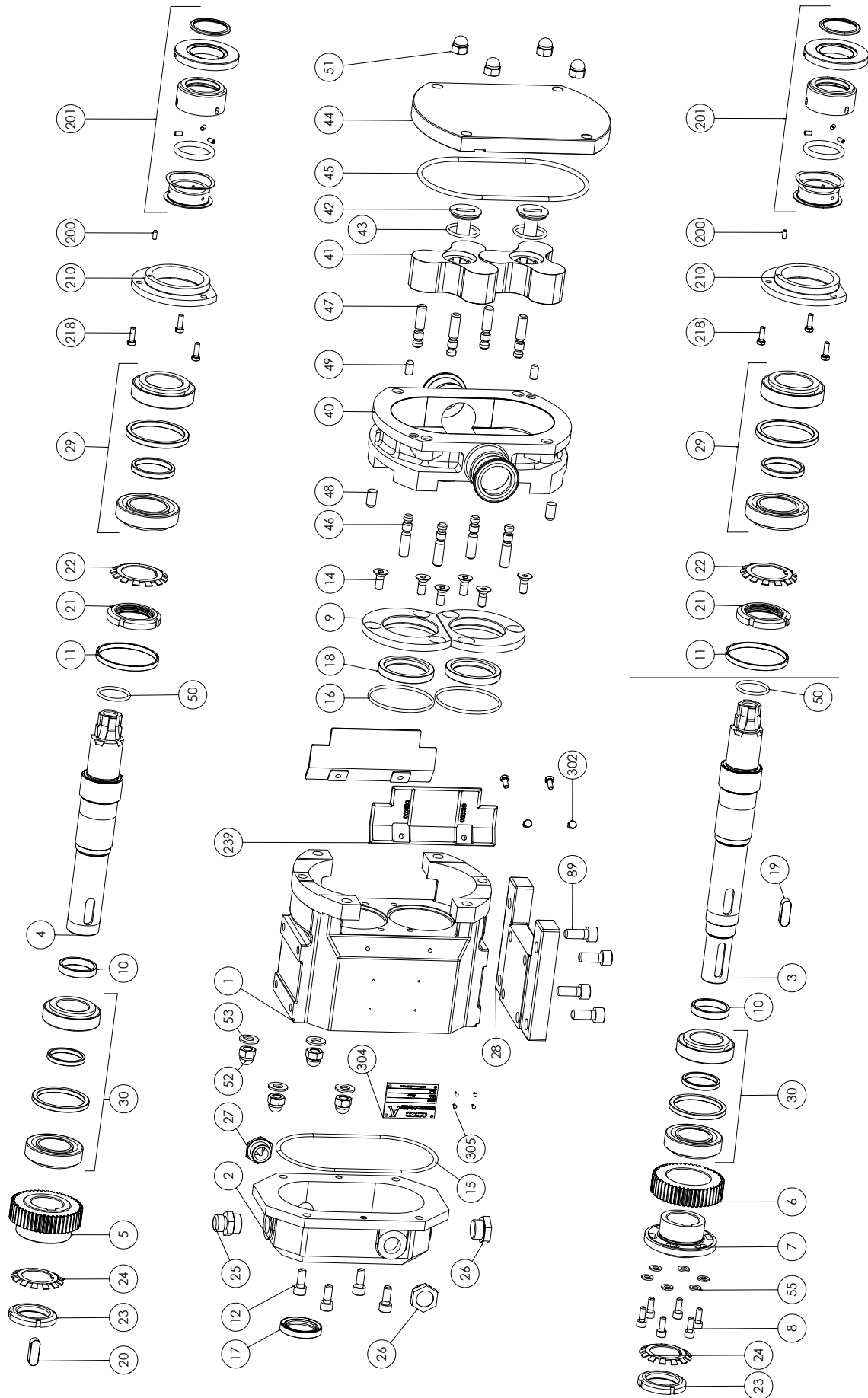

7.1.6.2 Spare parts names and codes

Pos.	Descriptions	Q.ty	BA470	BA490	BB470	BB490
1	BEARING HOUSING	1	2001G008			
2	GEAR COVER	1	2001L038			
3	STANDARD DRIVING SHAFT	1	2004B067	2004B069	2004B067	2004B069
3	DUPLEX DRIVIGN SHAFT	1				
3	DOUBLE FLUSH. MEC. SEAL DRIVING SHAFT	1	2004B068	2004B070	2004B068	2004B070
4	STANDARD DRIVEN SHAFT	1				
4	DUPLEX DRIVEN SHAFT	1				
4	DOUBLE FLUSH. MEC. SEAL DRIVEN SHAFT	1				
5	FIXED GEAR	1	2008M014			
6	ADJUSTABLE GEAR	1	2008M015			
7	ADJUSTABLE GEAR BUSH	1	2008M037			
8	SCREW	6	411F10X30			
9	BEARING RETAINER	2	2001C057			
10	BEARING SPACER	2	-			
11	AXIAL ADJUSTMENT SPACER	2	2014M044			
12	SCREW	4	411A10X30			
13	GEAR COVER PIN	2	417A8X16			
14	SCREW	8	411A10X25S			
15	GEAR COVER O'RING	1	404T81050			
16	BEARING RETAINER O'RING	2	404T4500			
17	OIL SEAL RING	1	403Y658510D			
18	OIL SEAL RING	2	403Y9011012D			
19	KEY	2	418F20X60M			
20	KEY	1	418F16X90			
21	BEARING RING NUT	2	415F80			
22	WASHER	2	416F80			
23	GEAR RING NUT	2	415F70			
24	WASHER	2	416F70			
25	OIL VENT CAP	1	407L12S			
26	OIL CAP	2	407L12T			
27	OIL LEVEL	1	407L12L			
28	FOOT	1	2001G105			
29	ASSEMBLED FRONT BEARING	2	2019M008			
30	ASSEMBLED REAR BEARING	2	2019M004			
31	VERTICAL FOOT	2	2001A305			
32	SCREW	8	411A20X40			
33	COUNTERFLANGE FOR ENLARGED INLET PORT	1	-	2006B049	-	2006B049
34	O-RING	1	-	404U47253A	-	404T4725
40	ROTOR CASE (see separate list)	1	23...61	23...62	23...61B	23...62B
41	316 STAINLESS STEEL 3 LOBE ST	2			2005B178	2005B179
41	316 STAINLESS STEEL 3 LOBE SM	2				
41	316 STAINLESS STEEL 2 LOBE ST	2				
41	316 STAINLESS STEEL 2 LOBE SM	2				
41	316 S.STEEL. DUAL WING ROT. PIST ST	2				
41	316 S.STEEL. DUAL WING ROT. PIST SM	2				
41	ANTI-SEIZURE ALLOY DUAL WING ROT.PISTON	2				
41	ANTI-SEIZURE ALLOY 3 LOBE	2				
41	316 STAINLESS STEEL GEAR ROTOR	2				
41	ANTI-SEIZURE ALLOY GEAR ROTOR	2				
42	LOCKING NUT for STANDARD ROTOR	2				

Pos.	Descriptions	Q.ty	BA470	BA490	BB470	BB490
43	O-RING	2				
44	STANDARD FRONT COVER	1				
45	COVER O-RING	1				
46	BACK STUD	4		419A20X70		
47	FRONT STUD	8		419A14X55		
48	BACK PIN	2		417A16X40		
49	FRONT PIN	2		417A10X20		
50	O-RING	2				
51	CAP NUT	8		414A14		
52	CAP NUT	4		414A20		
53	PLANE WASHER	4		412A20		
54	PLANE WASHER	12		-		
55	PLANE WASHER	6		412F10		
56/1	BY PASS - COMPLETE RELIEF VALVE	1				
56	BY PASS SUPPORT	1				
57	BY PASS PISTON	1				
58	BY PASS COVER	1				
59	BY PASS ADJUSTEMENT SCREW	1				
60	THRUST WASHER	1				
61	ADJUSTMENT RING NUT	1				
62	BY PASS ADJUSTEMENT RETAINER	1				
63	SCREW	6				
64	SCREW	4				
65	SECURITY DOWEL	2				
66	SPLIT RING	1				
67	SPLIT RING	1				
68	O-RING	1				
69	O-RING	1				
71	SPRING	1				
72	END COVER FOR BY PASS	1				
89	SCREW	4				
91	PNEUMATIC BY PASS SUPPORT	1				
92	VTCEI SCREW	4-6(1)				
93	SUPPORT O-RING	1				
94	PISTONE BY-PASS PNEUMATICO	1				
93+94	PNEUMATIC BY-PASS PISTON+O-RING	1				
95	KEY	1				
96	PISTON O-RING	1				
97	ADJUSTMENT RING NUT	1				
98	SECURITY DOWEL	2				
99	PNEUMATIC BY PASS COVER	1				
100	BACK COVER O-RING	1				
101	FRONT COVER O-RING	1				
102	PISTON-COVER O-RING	1				
103	PNEUMATIC BY PASS JACKET	1				
104	SCREW	6				
105	THRUST RING	1				
106	PISTON ROD-THRUST O-RING	1				
107	THRUST-JACKET O-RING	1				
108	RING NUT	2				

Pos.	Descriptions	Q.ty	BA470	BA490	BB470	BB490
111	END COVER FOR HEATING VERSION	1				
112	END COVER FOR ASEPTIC VERSION	1				
113	END COVER JACKET	1				
114	TCEI SCREW	4				
115	END COVER JACKET O-RING	1				
116	INTERNAL COVER O'RING for ASEPTIC vers.	1				
117	EXTERNAL COVER O'RING for ASEPTIC vers.	1				
118	CONNECTION COUNTER FLANGE for AS.ver.	2				
119	INTERNAL CONNECTION O'RING for AS.ver.	2				
121	SCREW	12				
239	SEALS PROTECTION	2	4034A007			
302	SCREW	4	410A05X10		410A05X10	
303	PLUG	4	44301025		44301025	
304	NAME PLATE	1	4434A103		4434A102	
305	RIVET	4	44301027			
306	EYEBOLT	2	-			-

7.1.6.3 Seals section drawings and spare parts

Single mechanical seal 7KFO

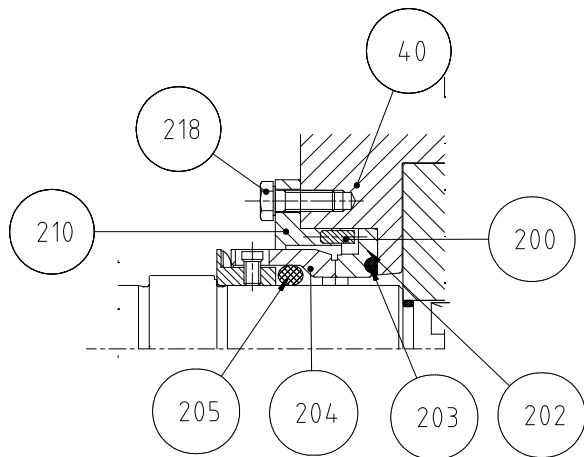

Single flushed mechanical seal 7KFO

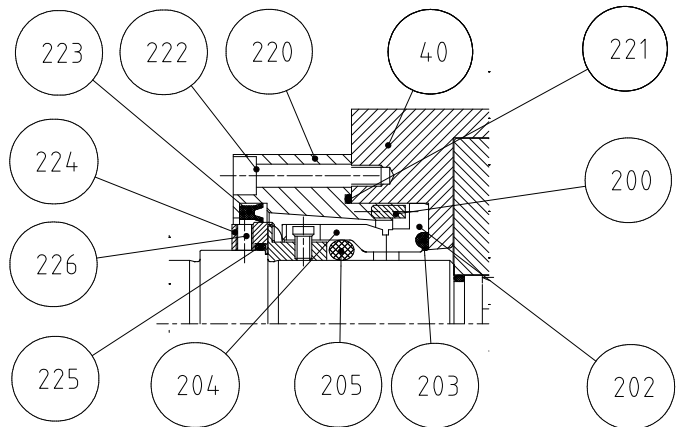

Pos.	Descriptions	Q.ty	BA470	BA490	BB470	BB490
200	Seal stop pin	2	430A04X10			
201	Mechanical seal 7KFO (pos.202+203+204+205)	2	4U0807KFO...			
202	Mech. Seal Stationary part	2				
203	Stationary part o-ring	2				
204	Mech. Seal Rotating part	2				
205	Rotating part o-ring	2				
210	Balancing ring	2	2014B035			
218	Balancing ring screw	6	410A10X20			
220	Flushing seal box	2				
221	O-ring	2				
222	Screw	6				
223	Seal ring UM	2				
224	Rotating Ring	2				
225	Bush o-ring	2				
226	Security dowel	6				

Pos.201 = (202+203+204+205)

7.2 Name and codes of pumping bodies

This naming refers to position n. 40 (pumping body) of the construction exploded view drawings in sections 7.1.1.1, 7.1.2.1, 7.1.3.1, 7.1.4.1, 7.1.5.1, 7.1.6.1 and identifies the item code to order as a spare part.

Example: code 23102B07

2	3	1	0	2	B	0	7
A	B	C	D	E	F	G	G

Code 23102B07 identifies the finished body, with heated chamber, for mechanical seals, for DIN11851 openings, made of AISI 316 L material, for the size of the LPDP.

The code of the pump bodies is made up as follows:

A	B	C	D	E	F	G	G
---	---	---	---	---	---	---	---

A	CODIFY	2 = FINISHED PART	5 = SEMIFINISHED PART	6 = CAST PART
----------	---------------	-------------------	-----------------------	---------------

B	FAMIGLIA	3 = FAMILY MEMBERSHIP		
----------	-----------------	-----------------------	--	--

C	VERSION	0 = STANDARD	1 = HEATED PUMP BODY	2 = ASEPTIC	3 = HEATED ASEPTIC
		4 = HIGH PRESSURE	5 = HIGH PRESSURE + HEATED PUMP BODY	6 = ENLARGED INLET PORT	7 = ENLARGED INLET PORT + HEATED PUMP BODY

D	HOUSING TYPE SEALS	0 = MECHANICAL AND LIP SEAL	1 = PACKING GLAND SEAL	9 = SPECIAL
----------	---------------------------	-----------------------------	------------------------	-------------

E	CONNECTIONS	0 = THREAD GAS-BSP	1 = FLANGE PN 16 UNI2278	2 = DIN11851	3 = SMS	4 = RJT
		5 = IDF-ISS	6 = TRI-CLAMP	7 = GAS	8 = ENOLOGIC	9 = SPECIAL

F	MATERIAL	B	H	I	J	R
----------	-----------------	---	---	---	---	---

G-G	Numerical order in relation to the size				
------------	---	--	--	--	--

7.3 Codes of the springs used in the mechanical safety valve

The table below list the identification codes of the springs used in the mechanical safety valves (see ref. section 3.3.3), codes that can be used to order any spare parts.

PUMP	SPRING CODE		
BA BB BF 100	(0 ÷ 5 bar) VL12.5X25 code 422F015	(6 ÷ 10 bar) code 422F016	-
BA BB BF 105 110 115	(0 ÷ 13 bar) Ø5 code 422F001	(14 ÷ 17 bar) code 422F011	(18 ÷ 20 bar) code 422F002
BA BB BF 215 220	(0 ÷ 13 bar) Ø5 code 422F001	(14 ÷ 17 bar) code 422F011	(18 ÷ 20 bar) code 422F002
BA BB BF 325 330 BA BB 390	(0 ÷ 7 bar) code 422F003	(8 ÷ 13 bar) code 422F004	(14 ÷ 17 bar) code 422F005
BA BB 430 440	(0 ÷ 7 bar) code 422F017	(8 ÷ 11 bar) code 422F007	(12 ÷ 17 bar) code 422F008
BA BB 470 490	(0 ÷ 7 bar) code 422F013	(8 ÷ 15 bar) code 422F014	-

7.4 Codes of the springs used in the external bridge mechanical safety valve

The table below lists the kinds of springs used in the external bridge mechanical safety valves (see ref. section 3.3.3): depending on the adjustment pressure and valve diameter one can recognise the spring identification letter: "A", "B", "C", "D", "E".

VALVE DIMENSION	PRESSURE (BAR)				
	SPRING "A"	SPRING "B"	SPRING "C"	SPRING "D"	SPRING "E"
DN 25	0.5 ÷ 2 bar	1 ÷ 3.5 bar	1 ÷ 6.5 bar	1 ÷ 9 bar	1 ÷ 10 bar
DN 32	0.5 ÷ 2 bar	1 ÷ 3.5 bar	1 ÷ 6.5 bar	1 ÷ 9 bar	1 ÷ 10 bar
DN 40	0.5 ÷ 2 bar	1 ÷ 3.5 bar	1 ÷ 6.5 bar	1 ÷ 9 bar	1 ÷ 10 bar
DN 50		0.5 ÷ 2 bar	1 ÷ 3.7 bar	1 ÷ 6 bar	1 ÷ 10 bar
DN 65			0.5 ÷ 2 bar	0.5 ÷ 3.3 bar	1 ÷ 7.7 bar
DN 80			0.5 ÷ 1.7 bar	0.5 ÷ 2.3 bar	1 ÷ 5 bar
DN 100				0.5 ÷ 1.3 bar	0.5 ÷ 4 bar

7.5 Recommended spare parts

It is advisable for the Customer, in order to ensure the shortest plant down time, to stock up on spare parts relating to sealing parts complete with gaskets.

The codes relating to these components can be found in sections 7.1.1.3 - 7.1.2.3 - 7.1.3.3 - 7.1.4.3 - 7.1.5.3 - 7.1.6.3, depending on the size of the BA BB BF Series LPDP, part of the LPDPG.

7.6 How to order spare parts

With reference to the previous sections, the single parts that compose the LPDP are marked with an internal O.M.A.C. code.

This code is of vital importance when communicating with our spare parts department.

In order to have the spare parts delivered quickly you must communicate the following data to us, even via a purchase order:

- ✦ machine model (*)
- ✦ serial number (*)
- ✦ component description
- ✦ component reference code (refer to the attachments of the manual)
- ✦ desired amount.

(*) information that can be found on the machine, on the nameplate

Contacts:

Tel.: 0522/629371 or 0522/629923 and ask for the "spare parts" department

Fax: 0522/628980

E-mail: info@omacpompe.com

CHAPTER 8: ASSISTANCE

O.M.A.C. S.r.l. has a customer after-sales assistance service that can solve any problem in relation to the LPDPG.
In the case there are anomalies in the LPDPG used, contact our after-sales assistance service which will see to solve the problem.

Contacts:

- ▲ Tel.: 0522/629371 or 0522/629923 and ask for the "assistance" department
- ▲ Fax: 0522/628980
- ▲ E-mail: info@omacpompe.com

Only O.M.A.C. S.r.l. technical personnel is qualified to carry out extraordinary maintenance activities that the LPDPG requires.

CHAPTER 9: WARRANTY

O.M.A.C. S.r.l. grants a warranty for twenty-four to months from the date of delivery for new LPDPG that have been subjected to normal work of eight hours a day, while if they will be subjected to a double or triple work shift, during the day, the warranty term will be respectively reduced by half (in the case of a double work shift) or by a third (in the case of a triple work shift).

Unless otherwise agreed, the warranty is only for new LPDPG manufactured by the seller and used as described in the attached technical sheet, thus excluding LPDPG used in unintended manners, overhauled LPDPG and those parts of LPDPG built by other companies for which the warranties of the respective manufacturers apply (electrical panel, bridge By-Pass, etc.).

The warranty consists in repairing or replacing all pieces that are possibly defective in terms of materials or processing, returned free port to the headquarters of OMAC s.r.l.

The warranty does not extend to failures resulting from improper installation, inexperience in the running the LPDPG, from poor maintenance, negligence, when changes have been made to the LPDPG or non-original spare parts have been used, without the written consent of OMAC s.r.l. Electrical components are always excluded from the warranty.

Under no circumstances can the manufacturer be charged for damages due to non-compliance with our requirements, or manipulations carried out by untrained personnel. Under no circumstances can we replace for free those pieces whose failure or breakage depends on normal wear and tear, misuse, or in inappropriate use conditions or use of the LPDPG other than what was agreed in the sale contract.

Any assistance required during the warranty period must be carried out solely by OMAC s.r.l. skilled technicians. In the case this LPDPG is used for abrasive/corrosive products, this warranty is reduced to 2 months.

If the LPDPG is tampered with by unauthorised personnel the warranty is voided.

All repairs or replacements of pieces for failures not attributable to manufacture defects or poor quality of the material will be charged in full to the Customer.



WARNING

An installation other than that indicated in chapter, a use other than that indicated in chapter 4, the possible seizure of rotors, caused by foreign bodies, such as pipe process scraps, welding cinders, dust, etc. will void the warranty.



OMAC

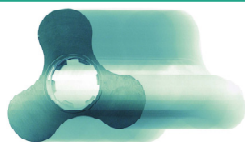

O.M.A.C. S.R.L.
Via G. Falcone nr. 8 – 42048 RUBIERA (RE) – ITALY (UE)
Tel. 0522/629371 – 629923 / Fax. 0522/628980
WebSite: www.omacpompe.com E-mail: info@omacpompe.com

