

Mixing Technologies Side Entering Agitators

Reliable
Performance and
Dependability



The Proof is in the Performance

Innovative Solutions to Satisfy Your Needs

We have the capabilities, knowledge and experience to effectively evaluate application requirements and apply and/or customize our high quality mixing equipment to provide innovative mixing solutions that:

- Perform consistently
- Minimize maintenance costs and downtime
- Provide long service life
- Optimize total cost of ownership

We market our side entering agitators under the Chemineer™ and Prochem™ brand names. Side entering agitators as compared to top entering agitators typically:

- Utilize higher HP at faster rotational speeds
- Mount easily to the side of vessel with a simple pipe leg support on tie rods
- Have shorter shaft lengths and weigh less

The Mixing Technologies Difference

The extensive line of Chemineer and Prochem side entering agitators offers numerous benefits to the customer not often found in competitive equipment including:

- **Application versatility**—proprietary ChemScale™ method for effective agitator selection with both gear or belt driven configurations
- **Proven performance and extended service life**—heavy duty bearings and shafts
- **Optimal mixing efficiency**—high performance impeller options
- **Ease of maintenance**—tank shut off devices and multiple sealing options



Prochem side entering agitators satisfy critical mixing applications worldwide

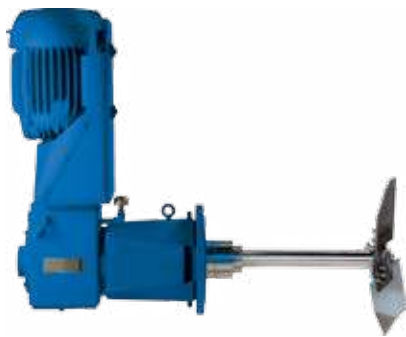

HS



PB



MD

Drive Choices for Application Versatility

We manufacture and market both gear driven and belt driven, side entering agitators with over 60 years of field proven performance. Designed for demanding applications

in Pulp and Paper, Flue Gas Desulphurization (FGD), Biofuel, Petroleum Blending and Storage, BS&W and CPI vessels to name but a few, these agitators provide rugged dependability, application versatility and easy, economical maintenance.

We offer three side entering agitator designs to meet the specific requirements of your applications. The HS agitators feature a spiral bevel gear driven design for demanding applications that include significant fluctuations in load. The PB agitators feature a belt driven design that incorporates

a pillow block bearing configuration for economical performance and easy maintenance. The MD agitators also feature a belt driven design, but incorporate an innovative bearing cartridge configuration that protects the bearings from the process fluids.

Chemineer Gear Driven Agitator Advantages

The HS gear driven, side entering agitators offer ruggedness and dependability in an extensive range of applications. Designed for maximum service life, the HS agitators use precision machined, surface hardened spiral bevel gear sets, high capacity tapered roller bearings and heavy duty output shafts.

Features and Benefits

	Features	Benefits
Design Parameters	<ul style="list-style-type: none"> • Four standard sizes ranging from 1 to 75 HP • Custom designs available for higher HP applications 	<ul style="list-style-type: none"> • Extensive power options to satisfy a variety of applications
	<ul style="list-style-type: none"> • Two standard output speeds <ul style="list-style-type: none"> - 350 and 230 rpm for 60 Hz designs - 290 and 190 rpm for 50 Hz designs 	<ul style="list-style-type: none"> • Application versatility to meet specific requirements
Gearing and Bearings	<ul style="list-style-type: none"> • Hardened spiral bevel gearing 	<ul style="list-style-type: none"> • Higher power transfer efficiency than other types of gearing for heavy duty performance • Generates less heat for long service life
	<ul style="list-style-type: none"> • All gears load rated per AGMA standards and inspected to AGMA Quality 10 levels 	<ul style="list-style-type: none"> • High quality ensures performance to meet all demands
	<ul style="list-style-type: none"> • High capacity, tapered roller bearings used throughout 	<ul style="list-style-type: none"> • Exceptional wear resistance and long service life • Rated at a minimum of 30,000 hour L-10 bearing life • All bearings mounted on carriers for easy maintenance

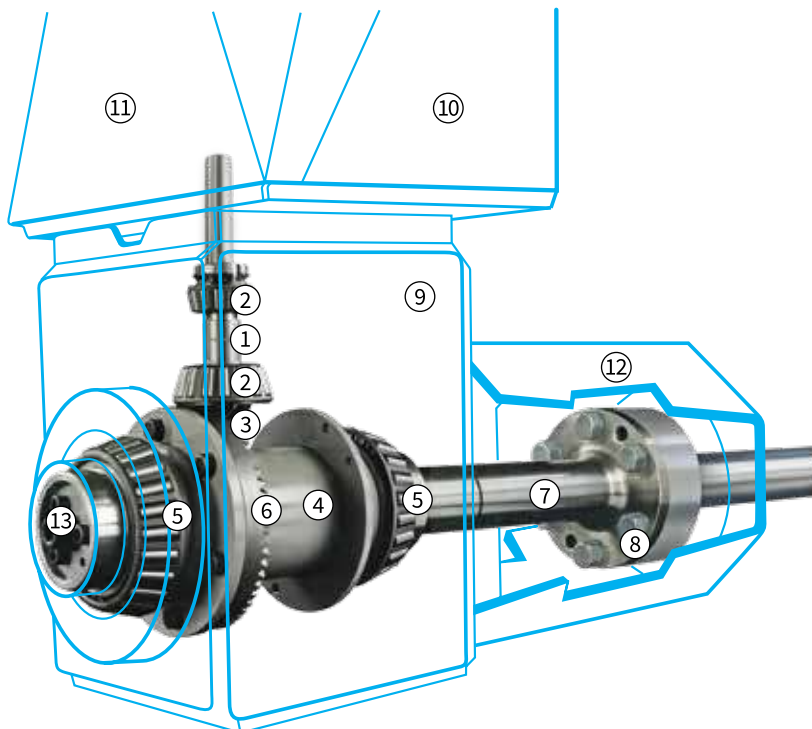

Gearbox Components

- 1 Spiral bevel pinion shaft
- 2 High speed shaft bearings
- 3 Spiral bevel pinion
- 4 Hollow shaft
- 5 Low speed shaft bearings
- 6 Spiral bevel gear
- 7 Drive shaft
- 8 Extension shaft coupling (with mechanical seal only)
- 9 Housing
- 10 Motor bracket
- 12 Coupling guard
- 13 Pedestal
- 14 Retract mechanism

Features and Benefits

	Features	Benefits
Shafts and Seals	• Large low speed shaft	• Resists deflection and prevents gear misalignment
	• Rugged, high quality extension shaft	• Minimizes deflection for excellent sealing and extended seal life
	• Output shafts available in carbon steel, 304 stainless steel, 316 stainless steel and other alloys	• Application versatility to meet a wide range of applications
	• Packed stuffing box and single, split or double mechanical seals and slurry seal are available	• Shaft sealing options provide versatility to cost effectively meet customer preferences
	• Easy seal change out	• Improves uptime of your process
Housing and Lubrication	• Drive housing, motor bracket and pedestals are all fabricated from steel plate, machine welded and precision machined	• Reduces noise level • Rugged protection of gearing for long service life • Accurate bearing alignment
	• Compact, right angle configuration	• Takes up less space • Minimizes overhung load and reduces nozzle reinforcement requirements
	• Splash lubricated	• Ensures vital lubrication to gears and bearings at all operating speeds for long service life
	• Double lip seals on drive shafting	• Prevent oil loss or contaminant infiltration for long service life
Tank Shut Off	• A standard tank shut off device contains vessel contents during routine maintenance	• No need to disassemble the agitator for routine maintenance to minimize downtime and cost

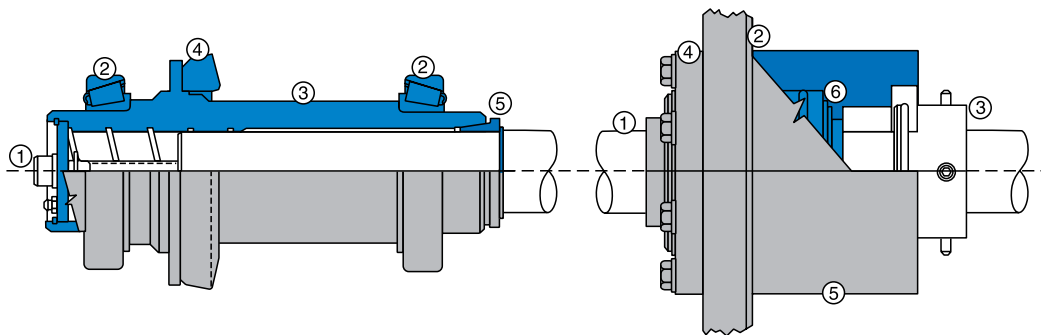

Drive Internals

- | | |
|-------------------------|------------------------|
| 1 Retract bolt assembly | 4 Spiral bevel gear |
| 2 Bearings | 5 Split tapered collar |
| 3 Hollow drive shaft | 6 Spiral bevel gear |

Shaft Seal

- | | |
|-------------------|---|
| 1 Extension shaft | 4 Cartridge seal |
| 2 Mounting flange | 5 Housing (integral with mounting flange) |
| 3 Shut off collar | 6 Throttle bushing |

Gear Driven Agitator Dimensions

Agitator Dimensions

Case Size	1	2	3	4
B	11"	11"	14"	17.25"
C	6.5"	6.5"	8.5"	10.5"
D	25.5"	25.5"	32.125"	38.5"
E	19.75"	19.75"	25"	28.75"
F	8"	8"	12"	12"
G	5.125"	5.125"	7.0625"	9.3125"
H	10.25"	10.25"	14.125"	18.625"
J	26"	26"	33"	38"
V	2"	2"	3"	3.5"

Motor Dimensions

(for totally enclosed and explosion proof, 1750 rpm motors)

HP ①		Frame	A	P
1150 rpm	1750 rpm			
1	1	143T	12.25"	7.75"
1	1.5, 2	145T	13"	
1.5	3	182T	14.375"	9.25"
2	5	184T	15.375"	
3	7.5	213T	18"	11"
5	10	215T	29.5"	
7.5	15	254T	22.875"	12.75"
10	20	256T	24.625"	
15	25	284T	26.625"	14.5"
20	30	286T	28.125"	
25	40	324T	39.625"	16.875"
30	50	326T	31.125"	
40	60	364T	32.5"	18.5"
50	75	365T	33.5"	

Mounting Dimensions

Case Size	1	2	3	4
K	20.75"	20.75"	27.125"	31.625"
L	6.25"	6.25"	7.75"	9.875"
M	66"-72"	66"-72"	78"-84"	90"-96"
N	21.375"	21.375"	27.6875"	33.5"
R	27"	27"	34"	37"
S	0.4375"	0.4375"	0.5625"	0.6875"
T	2"	2"	2.25"	2.5"
U	4"	4"	4.5"	5"

① 230 rpm units use 1150 rpm motors; 350 rpm units use 1750 rpm motors

② Impeller diameter and other options to suit application

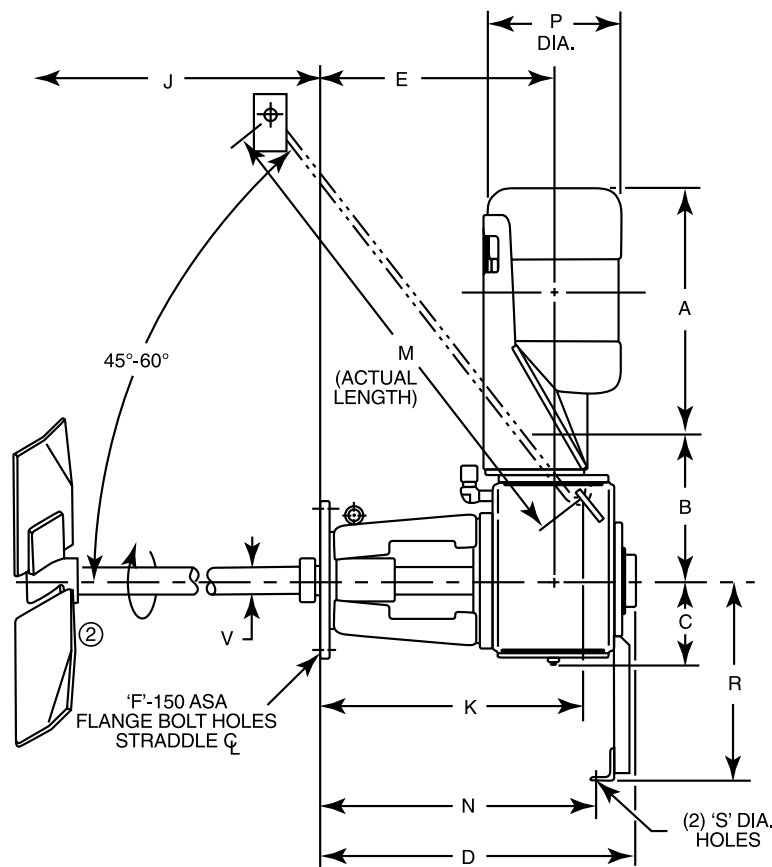

HS

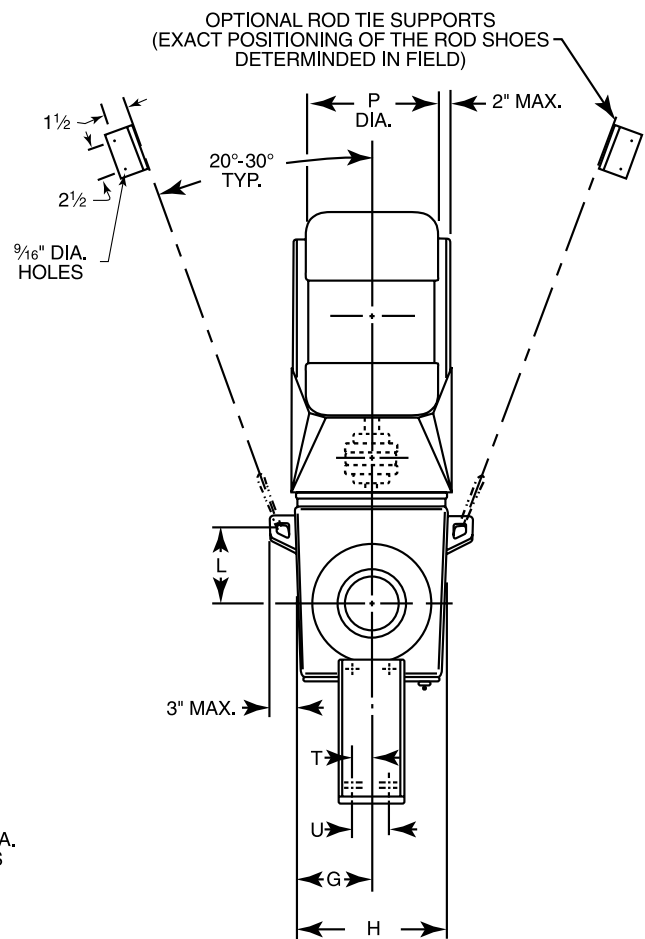

Prochem Belt Driven Agitator Advantages

The PB and MD belt driven, side entering agitators provide easy to maintain configurations that minimize downtime and maintenance costs. Field proven performance for over 40 years makes Prochem agitators the ideal choice for a broad range of applications.

Features and Benefits

	Features	Benefits
Design Parameters	<ul style="list-style-type: none"> Standard belt drive service factor is 1.3 with optional 1.5 and 2.0 available 	<ul style="list-style-type: none"> Aligns with customers' equipment specification requirements
	<ul style="list-style-type: none"> Up to 300 HP as standard with designs up to 400 HP available (PB); up to 250 HP as standard with designs up to 500 HP available (MD) 	<ul style="list-style-type: none"> Extensive power options to satisfy a variety of applications
	<ul style="list-style-type: none"> Wetted parts available in many highly corrosion resistant materials including 316 stainless steel, 317L stainless steel, hastelloy C or titanium and other alloys available as needed 	<ul style="list-style-type: none"> Corrosive and abrasive environments can be easily handled Extends service life of wetted parts Can meet a wide range of application requirements
Bearings	<ul style="list-style-type: none"> Pillow block bearing configuration (PB) 	<ul style="list-style-type: none"> No field alignment of bearings or packing needed due to prealignment on integral mounting base Easily accessible bearings access for economical maintenance
	<ul style="list-style-type: none"> Enclosed bearing cartridge configuration (MD) 	<ul style="list-style-type: none"> Innovative design allows quick and easy replacement of bearings as a unit to reduce downtime
	<ul style="list-style-type: none"> Minimum B-10 bearing life of 100,000 hours 	<ul style="list-style-type: none"> Long bearing life for low cost of ownership
	<ul style="list-style-type: none"> Bearing shields and slingers are standard 	<ul style="list-style-type: none"> Protects bearings from the process fluid for long bearing life



Pillow Block Assembly



Bearing Cartridge

Features and Benefits

	Features	Benefits
Shafts and Seals	<ul style="list-style-type: none"> • Shaft diameters up to 7 inches 	<ul style="list-style-type: none"> • Wide range of shaft options increases application versatility
	<ul style="list-style-type: none"> • Shafts designed to handle up to 10 times the normal operating load at full torque 	<ul style="list-style-type: none"> • Optimal performance and long service life in the most difficult applications
	<ul style="list-style-type: none"> • Packed stuffing box and single, split or double mechanical seals are available 	<ul style="list-style-type: none"> • Shaft sealing options provide versatility to cost effectively meet customer preferences
	<ul style="list-style-type: none"> • Chrome plated shaft sleeves are available 	<ul style="list-style-type: none"> • Extends shaft life in highly corrosive or abrasive applications to minimize costs
Belt Drives and Guards	<ul style="list-style-type: none"> • Ultra VX belts and sheaves are used on both the PB and MD agitators 	<ul style="list-style-type: none"> • Provides economical power transmission with shock absorbing capability for optimal performance and long life
	<ul style="list-style-type: none"> • Made to OSHA standards 	<ul style="list-style-type: none"> • Ensures operational safety of belt driven equipment
	<ul style="list-style-type: none"> • Ample ventilation regulates temperature 	<ul style="list-style-type: none"> • Cooler running agitators extend service life for low total cost of ownership
	<ul style="list-style-type: none"> • Guards on units with 3 inch or larger shafts contain access holes for adjusting belts 	<ul style="list-style-type: none"> • Quick and easy maintenance reduces costs
Housing and Mounts	<ul style="list-style-type: none"> • Designed to withstand severe loads many times that of typical application requirements 	<ul style="list-style-type: none"> • Quality construction extends service life
Tank Shut Off	<ul style="list-style-type: none"> • Optional tank shut off device contains vessel contents during routine maintenance 	<ul style="list-style-type: none"> • No need to disassemble the agitator for routine maintenance to minimize downtime and cost

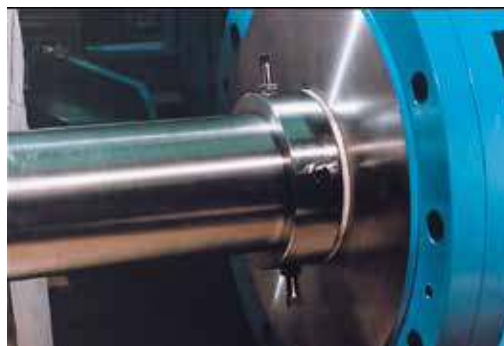

Tank Shut Off

Belt Driven Agitator Dimensions

Agitator Dimensions

Model	A	B	C	D	F	F	G	H	J	K	L	M	N	Net Weight
20PB1S	20.5"	23.0"	23.0"	22.3"	8.6"	5.8"	34.3"	8.0"	20.3"	31.8"	4.9"	1.0"	3.8"	400
30PB1S	20.5"	29.0"	32.3"	25.2"	10.5"	6.8"	37.3"	8.0"	28.1"	44.3"	6.6"	1.3"	3.8"	890
40PB1S	30.0"	34.0"	43.8"	33.8"	12.8"	7.3"	48.8"	10.0"	41.9"	63.8"	8.5"	1.3"	4.8"	2000
50PB1S	39.0"	43.0"	56.3"	35.9"	15.4"	9.0"	55.9"	15.0"	50.1"	78.3"	10.3"	1.5"	4.8"	2530
60PB1S	43.0"	47.0"	56.3"	39.8"	15.7"	11.0"	59.8"	15.0"	50.1"	78.3"	13.3"	1.8"	4.8"	3240
20MD1S	4.0"	12.0"	15.0"	23.0"	20.1"	5.8"	32.1"	7.0"	20.3"	31.8"	5.0"	4.8"	—	350
25/30MD1S	5.0"	14.0"	18.0"	32.3"	23.4"	6.8"	34.3"	7.0"	28.1"	44.3"	7.0"	3.7"	—	770
35/40MD1S	6.0"	18.0"	22.0"	43.8"	28.1"	7.3"	45.6"	10.0"	41.9"	63.8"	8.6"	7.4"	—	1740
45/50MD1S	7.0"	24.0"	30.0"	56.3"	36.1"	9.0"	57.1"	15.0"	50.1"	78.3"	10.0"	5.8"	—	2200
55/60/65MD1S	10.3"	23.8"	28.8"	56.3"	34.0"	11.0"	57.5"	15.0"	50.1"	78.3"	11.0"	8.3"	—	2820

1 Net weight does not include motor, impeller or shafting beyond mounting surface, all weights are in pounds and are approximate

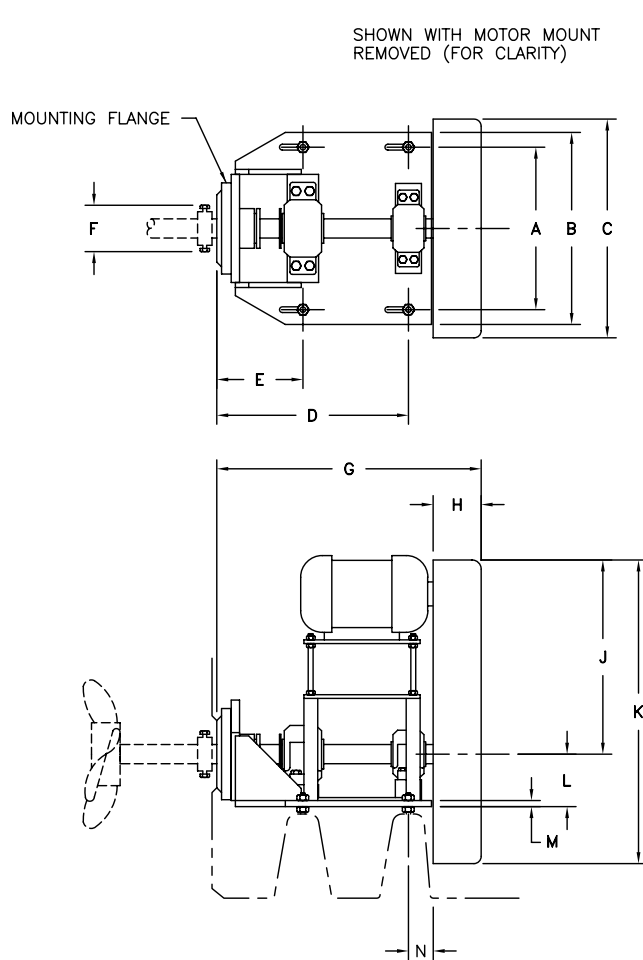

PB
S configuration shown
C & Z configurations available

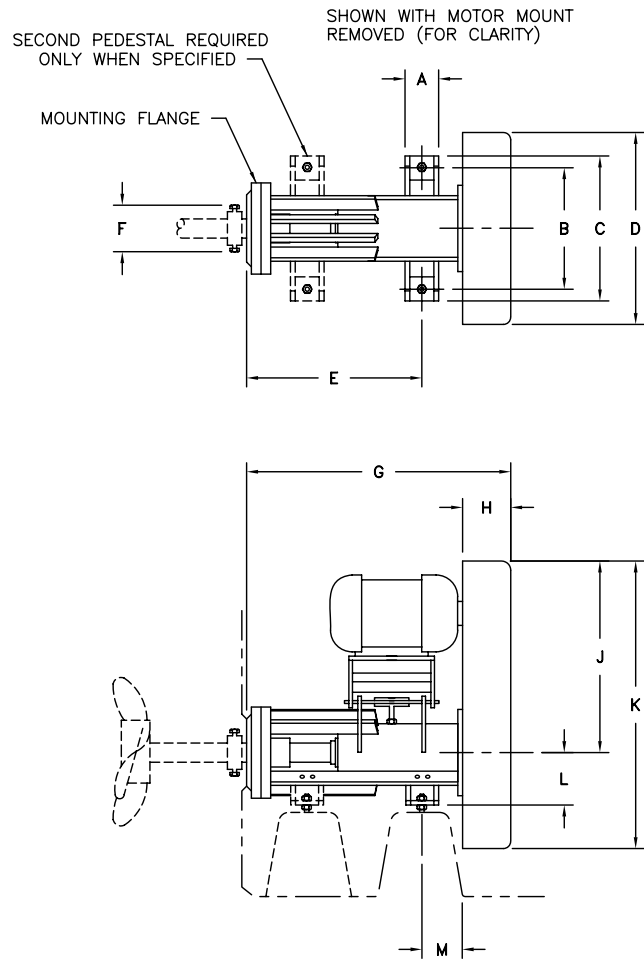

MD
S configuration shown
C & Z configurations available

Advanced Impeller Technology

The premier impeller for our side entering units is the WSE-3 which provides high pumping and low shear rates.

This proven performer offers:

- Reduced wear through lower tip speeds
- Hydrodynamic design for greater cavitation resistance than other impeller designs

- Easier maintenance with bolted blade construction
- High efficiency for maximum pumping action resulting from its hydrofoil design

In addition to the WSE-3 impeller, we also offer the Mark III or HE-3S upon request. Each impeller offers unique performance characteristics for specific application requirements.



HE-3S

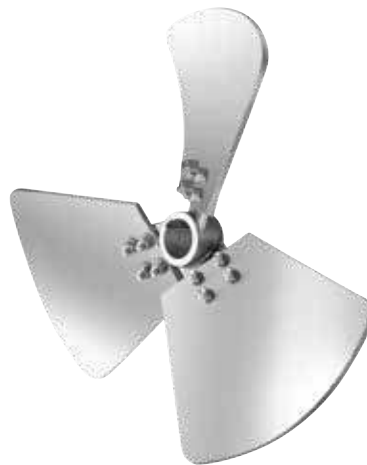

WSE-3



Mark III

Industry Leading Aftermarket and Technical Support

Features

Benefits

<ul style="list-style-type: none"> • Extensive network of factory trained field sales representatives and in house application engineers 	<ul style="list-style-type: none"> • Experienced application specialists provide effective fluid mixing solutions
<ul style="list-style-type: none"> • Superior field technical support and an extensive inventory of replacement parts available 	<ul style="list-style-type: none"> • Installation, maintenance and troubleshooting support reduces downtime and costs
<ul style="list-style-type: none"> • 24/7 hotline available 	<ul style="list-style-type: none"> • Call +1-937-926-1724



Manufacturing Facilities

US
+1 937 454 3200
chemineer@nov.com

US North Andover
+1 978 687 0101
navinfo@nov.com

United Kingdom
+44 1332 363 175
chemineeruk@nov.com

China
+86 21 6124 0001
chemineercn@nov.com

Singapore
+65 6271 1121
chemineeruk@nov.com

Mexico
+52 55 3300 5370
chemineerventasmx@nov.com

Austria
+43 1 8923481
chemineeruk@nov.com

Sales Facilities

US Ohio
+1 937 454 3200
chemineer@nov.com

US North Andover
+1 978 687 0101
navinfo@nov.com

United Kingdom
+44 1332 363 175
chemineeruk@nov.com

China
+86 21 6124 0001
chemineercn@nov.com

Singapore
+65 6271 1121
chemineeruk@nov.com

Mexico
+52 55 3300 5370
chemineerventasmx@nov.com

Austria
+43 1 8923481
chemineeruk@nov.com

National Oilwell Varco has produced this brochure for general information only, and it is not intended for design purposes. Although every effort has been made to maintain the accuracy and reliability of its contents, National Oilwell Varco in no way assumes responsibility for liability for any loss, damage or injury resulting from the use of information and data herein. All applications for the material described are at the user's risk and are the user's responsibility.

Corporate Headquarters

7909 Parkwood Circle Drive
Houston, Texas 77036
USA

