

Mark 80 Series

Self-Operated Temperature Regulators

The MK80 Series is completely self-operated and requires no external power source or other expensive instrumentation to operate the valve.

The operation of the MK80 is fairly simple. A pre-measured amount of liquid fill is drawn into the thermal system filling the upper diaphragm chamber, the capillary tube, and most of the bulb. As the controlled temperature increases, the volatile liquid fill in the sensing bulb begins to vaporize and creates pressure on the sealed system. This pressure drives the valve stem, closing direct acting valves, or opening reverse acting valves.

Because of the shorter stroke length of the sliding gate seats, the MK80 is able to utilize a sealed actuator with a stainless steel diaphragm, and does not require a bellows to operate. To seal the actuator, the upper and lower casings and diaphragm are heli-arc welded around the circumference to create a solid bond. This seal eliminates the need for any type of gasket. All sealing surfaces on the MK80 are metal to metal.

Accurate temperature control begins with a reliable actuator.

A temperature regulator is only as good as its actuator and a great deal of research has gone into the development of Jordan's stainless steel SWA actuator. That is why the SWA, combined with Jordan's sliding gate regulator design, provides the finest temperature control available in a self-operated design. Among the features of the SWA actuator:

- **Heliarc welded construction:** the upper and lower casings, and diaphragm, are heliarc welded around the circumference to fuse a solid bond and eliminate the need for a gasket, a common source for leakage.
- **Stainless Steel diaphragm:** pre-formed from AISI 347 SST to eliminate rupturing caused by metal fatigue brought about by constant stress, the most common failure in bellows actuators.
- **Sensitive control:** because of the stroke length, the span of an SWA is about 1/3 that of a typical bellows actuator.



- **Simple replacement:** attached to the yoke by just four screws, the actuator can be replaced in less than five minutes. Control ranges can be changed with the valve in line by simply replacing the actuator.
- **Liquid/vapor thermal system:** to obtain the force needed to position the valve seats, Jordan uses a liquid/vapor thermal system that is capable of delivering far more operating power than the simple liquid expansion systems used on other temperature regulators. As the sensed temperature increases, the liquid fill in the bulb begins to vaporize and creates pressure within the sealed system. This pressure, exerted on the diaphragm, drives the valve stem to modulate the valve seats to the proper position.

FEATURES

- High rangeability — controls flows from 5% to 100% of rated capacity.
- Sliding gate seats provide —
 - Straight-through flow for reduced turbulence and quiet operation
 - Short stroke for fast response and accurate temperature control
 - Easily interchangeable Cv's
 - Tight shutoff due to overlap of seat closure area
- Available with capillaries up to 100 feet in length.



Jordan Valve, a division of Richards Industries
 3170 Wasson Road • Cincinnati, OH 45209
 513.533.5600 • 800.543.7311 • 513.871.0105 (f)
 info@richardsind.com • www.jordanvalve.com

SPECIFICATIONS

Line Sizes: 1/4" (DN8) through 2" (DN50)

End Connections:

- Threaded — FNPT, BSPT, BSPP
- ANSI Flanges — 150#, 300#
- DIN Flanges — PN10/16, PN25/40

Body Materials:

- Ductile Iron
- Bronze
- Carbon Steel
- Stainless Steel

Trim Materials:

- 303 SS for DI, BRZ & CS body valves
- 316SS for SS body valves

Seat Materials:

- Jorcote on SST — Standard

Yoke Material: Carbon Steel

Stem Packing Materials:

- Spring-loaded Teflon (to 450°F max/232°C max)
- Braided (above 500°F/260°C up to 650°F/343°C)

Service: steam, water, oil, gas, air and chemicals

Shutoff: ANSI Class IV

Action:

- Direct (increase in temperature closes valve)
- Reverse (increase in temperature opens valve)

Body Rating (Max):

- Ductile Iron: 988 psi @ 100°F; 988 psi @ 450°F (68,1 bar @ 37,8°C; 68,8 bar @ 232,2°C)
- Carbon Steel: 1480 psi @ 100°F; 1235 psi @ 450°F (102,0 bar @ 37,8°C; 85,2 bar @ 232,2°C)
- Stainless Steel: 1480 psi @ 100°F; 990 psi @ 450°F (102,0 bar @ 37,8°C; 68,3 bar @ 232,2°C)
- Bronze: 500 psi @ 100°F; 350 psi @ 450°F (34,5 bar @ 37,8°C; 24,1 bar @ 232,2°C)
- -20°F (-28,9°C) temperature limit on all materials
- For other temperatures, consult factory

Overheat Protection: 100°F (38°C) above top of control range

Cv Values & Maximum Differential Pressure

Size		Flow Coefficient		Seat Material	Max ΔP	
Inches	DN	Cv	Kv		PSI	BAR
1/4"	8	0.84	0,74	Jorcote	300	20,68
3/8"	12	1.6	1,4	Jorcote	300	20,68
1/2" or 3/4"	15 or 20	2.5 or 4.4	2,15 or 3,78	Jorcote	300	20,68
1" or 1-1/4"	25 or 32	6.4 or 9.5	5,50 or 8,17	Jorcote	250	17,24
1-1/2"	40	15	12,9	Jorcote	175	12,07
2"	50	25 or 30	21,5 or 25,8	Jorcote	175	12,07

Low Flow Cv's Available

Reduced Cv's can be used in a valve of any size so long as the required Cv is a smaller value than the standard for that particular size. In addition, the following Cv values can be provided:

1.6 (1,4)	0.84 (0,72)	0.42 (0,36)	0.21 (0,18)	0.08 (0,07)	0.04 (0,03)
0.02 (0,017)	0.008 (0,007)	0.004 (0,003)	0.002 (0,0017)	0.0008 (0,0007) (N/A in 316SS)	

Available Temperature Control Ranges & Spans

Range °F (°C)	Thermal Fill	Temperature span from closed to open °F (°C) with standard spring*		
		1/4" - 3/4"	1" - 1-1/4"	1-1/2" - 2"
-20 to 20 ^{***} (-29 to -7)	Freon 22	8 (4)	12 (7)	16 (9)
10 to 55 ⁺ (-12 to 13)	Freon R134A	9 (5)	14 (8)	17 (9)
35 to 90 ⁺ (2 to 32)	Iso Butane	11 (6)	15 (8)	18 (10)
55 to 115 ⁺ (13 to 46)	N-Butane	11 (6)	15 (8)	18 (10)
80 to 140 ⁺ (27 to 60)	Ethyl Chloride	11 (6)	15 (8)	18 (10)
110 to 165 (43 to 74)	Freon R123	15 (8)	22 (12)	26 (14)
120 to 185 (49 to 85)	Ethyl Ether	15 (8)	22 (12)	26 (14)
160 to 225 (71 to 107)	Acetone	15 (8)	22 (12)	26 (14)
205 to 260 (96 to 127)	Isopropyl Alcohol	9 (5)	14 (8)	17 (9)
230 to 290 (110 to 143)	N-Propyl Alcohol	11 (6)	15 (8)	18 (10)
265 to 325 (129 to 163)	N-Butyl Alcohol	11 (6)	15 (8)	18 (10)
315 to 400 (157 to 204)	M-Xylene	12 (7)	19 (11)	21 (12)
380 to 450 (193 to 232)	P-Cymene	12 (7)	19 (11)	21 (12)

* Lower spans and ranges available with optional light spring.

** Requires reinforced actuator

THERMAL SYSTEM SPECIFICATIONS

Types of Bulbs

- Type C: Finned Bulb

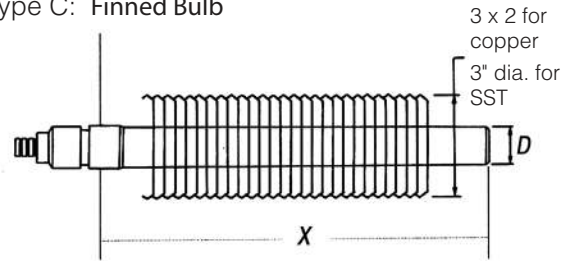

- Type D: Bulb with Rigid "Dead" Extension

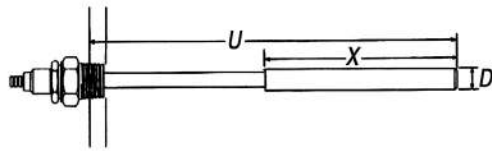

- Type E: Bulb with Pressure-tight Extension (well required for support when mounted horizontally)

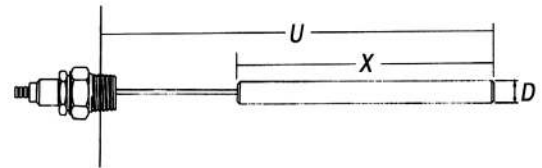

- Type F: Bulb Extension with Adjustable Union

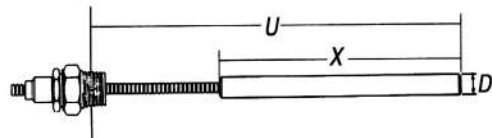

- Type A: Standard Bulb

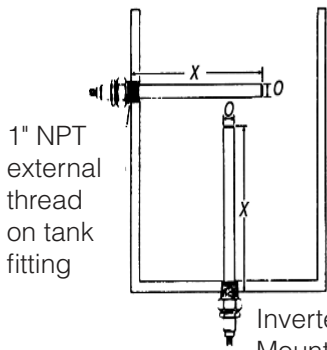

- Type B: Plain Bulb

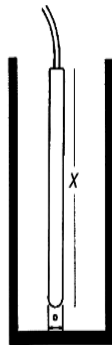

Inverted Mounting (must be specified on order)

Types of Thermal Wells

- Type A: standard threaded connection

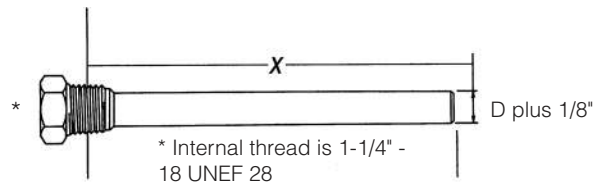

- Type B: optional flanged connection

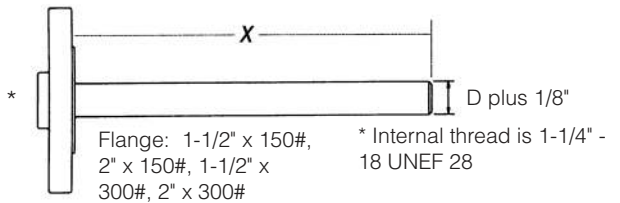

MARK 80 SELF-OPERATED TEMPERATURE REGULATORS

DIMENSIONS

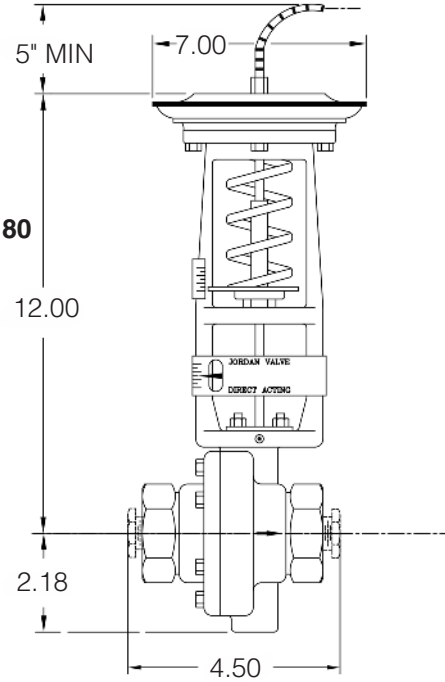
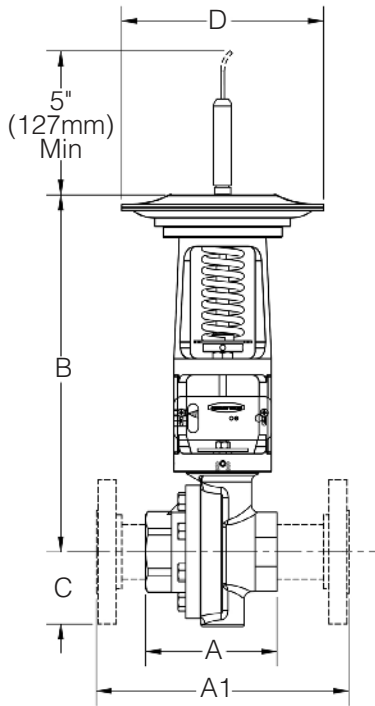

1/4" - 3/8" Mark 80

• Threaded Ends

Size	Material	Dimensions (inches)				Weight (lbs.)
		A	B	C	D	
1/4" & 3/8"	DI/BRZ	4.50	12.00	2.18	7.00	20
	CS/SS	4.50	12.00	2.18	7.00	21
1/2" & 3/4"	DI/BRZ	3.62	12.00	2.18	7.00	20
	CS/SS	3.65	12.00	2.18	7.00	21
1"	DI/BRZ	4.12	12.25	2.62	7.00	22
	CS/SS	4.12	12.25	2.62	7.00	23
1-1/4"	DI/BRZ	4.12	12.25	2.62	7.00	22
1-1/2"	DI/BRZ	4.50	12.75	2.75	7.00	24
	CS/SS	4.65	12.75	2.75	7.00	25
2"	DI/BRZ	4.50	12.81	3.00	7.00	24
	CS/SS	5.50	12.81	3.00	7.00	27

• Flanged Ends

Size	ANSI Flange	Dimensions (inches)				Weight (lbs.)	
		A1	B	C	D	DI/BRZ	CS/SS
1/2"	150#	7.25	12.00	2.81	7.00	21	23
	300#	7.50	12.00	2.81	7.00	22	24
3/4"	150#	7.25	12.00	2.81	7.00	22	25
	300#	7.62	12.00	2.81	7.00	23	28
1"	150#	7.25	12.25	2.62	7.00	24	28
	300#	7.75	12.25	2.62	7.00	25	30
1-1/4"	150#	7.87	12.25	2.62	7.00	25	—
	300#	8.37	12.25	2.62	7.00	26	—
1-1/2"	150#	8.75	12.75	2.75	7.00	27	32
	300#	9.25	12.75	2.75	7.00	30	38
2"	150#	10.00	12.81	3.00	7.00	29	38
	300#	10.50	12.81	3.00	7.00	31	42

• Threaded Ends, Metric

Size (DN)	Material	Dimensions (mm)				Weight (kg)
		A	B	C	D	
8 & 12	DI/BRZ	114	305	55	178	9,1
	CS/SS	114	305	55	178	9,5
15 & 20	DI/BRZ	92	305	55	178	9,1
	CS/SS	93	305	55	178	9,5
25	DI/BRZ	105	311	67	178	10,0
	CS/SS	105	311	67	178	10,4
32	DI/BRZ	105	311	67	178	10,0
40	DI/BRZ	114	324	70	178	10,9
	CS/SS	118	324	70	178	11,3
50	DI/BRZ	114	325	76	178	10,9
	CS/SS	140	325	76	178	12,2

• Flanged Ends, Metric

Size (DN)	Flange (PN)	Dimensions (mm)				Weight (kg)	
		A1	B	C	D	DI/BRZ	CS/SS
15	10/16	184	305	55	178	9,5	10,4
	25/40	191	305	55	178	10	10,9
20	10/16	184	305	55	178	10	11,3
	25/40	194	305	55	178	10,4	12,7
25	10/16	184	311	67	178	10,9	12,7
	25/40	197	311	67	178	11,3	13,6
32	10/16	200	311	67	178	11,3	—
	25/40	213	311	67	178	11,8	—
40	10/16	222	324	70	178	12,2	14,5
	25/40	235	324	70	178	13,6	17,2
50	10/16	254	325	76	178	13,2	17,2
	25/40	267	325	76	178	14,1	19,1

MARK 80 SELF-OPERATED TEMPERATURE REGULATORS

ORDERING SCHEMATIC

1	—	2	—	3	/	4	5	6	7	8	9	10	11

1	Model	
	80	Standard
	80T	with Thermometer

2	Size (DN)	
	025	1/4" (DN8)
	038	3/8" (DN12)
	050	1/2" (DN15)
	075	3/4" (DN20)
	100	1" (DN25)
	125	1-1/4" (DN32)
	150	1-1/2" (DN40)
	200	2" (DN50)

3	Body Material	
	DI	Ductile Iron
	BR	Bronze
	CS	Carbon Steel
	S6	Stainless Steel

4	End Connections			
	PT	NPT	I7	PN10 DIN IFE
	BT	BSPT	F7	PN10 FE (except IFE)
	BP	BSPP	I6	PN16 DIN IFE
	SW	FSW	F6	PN16 FE (except IFE)
	F1	125# FE	I8	PN25 DIN IFE
	I5	150# IFE	F8	PN25 FE (except IFE)
	F5	150# FE (except IFE)	I4	PN40 DIN IFE
	F2	250# FE	F4	PN40 FE (except IFE)
	I3	300# IFE	ZZ	Non-Standard
	F3	300# FE (except IFE)		

5	Trim	
	T3	303SS / Teflon Packing
	T6	316SS / Teflon Packing
	TM	Monel / Teflon Packing
	TA	Alloy 20 / Teflon Packing
	TH	Hastelloy C / Teflon Packing
	I3	303SS / 287-I Packing
	I6	316SS / 287-I Packing
	IM	Monel / 287-I Packing
	IH	Hastelloy C / 287-I Packing
	ZZ	Non-Standard

6	Seats			
	Material		Cv	
	Q	303 / Teflon	Y	0.0008
	R	316 / Teflon	E	0.0002
	S	Monel / Teflon	F	0.004
	T	Alloy 20 / Teflon	G	0.008
	U	Hastelloy C / Teflon	H	0.02
	V	303SS / Jorcote	I	0.04
	W	316SS / Jorcote	J	0.08
	1	303SST w/std. W.H.	1	0.21
	2	316SST w/std. W.H.	2	0.42
			3	0.84
			4	1.6
			5	2.5
			6	4.4
			7	6.4
			8	9.5
			9	15
			A	25
			B	30
	ZZ	Non-Standard		

Continued on page 6

ORDERING SCHEMATIC (CONT'D)

7	Range			
	Standard Spring °F		Standard Spring °C	
	06	-20 to 20*	A6	-29 to -7
12	10 to 55	B2	-12 to 13	
19	35 to 90	B9	2 to 32	
27	55 to 115	C7	13 to 46	
35	80 to 140	D5	27 to 60	
42	110 to 165	E2	43 to 74	
49	120 to 185	E9	49 to 85	
58	160 to 225	F8	71 to 107	
66	205 to 260	G6	96 to 127	
72	230 to 290	H2	110 to 143	
81	265 to 325	J1	129 to 163	
88	315 to 400	J8	157 to 204	
93	380 to 450	K3	193 to 232	
Light Spring °F		Light Spring °C		
05	-25 to -5*	A5	-32 to -21	
11	5 to 35	B1	-15 to 2	
17	30 to 70	B7	-1 to 21	
24	50 to 90	C4	10 to 32	
32	75 to 115	D2	24 to 46	
41	105 to 140	E1	41 to 60	
46	115 to 160	E6	46 to 71	
56	155 to 200	F6	68 to 93	
64	195 to 235	G4	91 to 113	
71	225 to 270	H1	107 to 132	
79	260 to 300	H9	127 to 149	

* Requires reinforced actuators

8	Thermowell			
	Type, Fitting & Material		Size for Bulb Diameter x Length	
	A	Type A, 1" NPT, Cu	A	1" x 12" (24,5mm x 304,8mm)
B	Type A, 1" NPT, SST	B	1" x 14" (24,5mm x 355,6mm)	
E	Type B, 1-1/2" x 150#, SST			
F	Type B, 1-1/2" x 300#, SST			
G	Type B, 2" x 150#, SST			
H	Type B, 2" x 300#, SST			
Tank Fitting Only				
11	1" NPT Brass for 1" Bulb			
12	1" NPT SST for 1" Bulb			
NN	None			

9	Thermowell System								
	Bulb: Refer to the standard bulb dimensions chart for metrics	Cap/Arm ft (m)	Actuator	Type					
				Material	Dimensions				
N1N1Q	1" x 12"	Copper Type A	SWA						
N2N1Q	1" x 14"								
A1A2A	1" x 12"								
A2A2A	1" x 14"								
A1A4A	1" x 12"								
A2A4A	1" x 14"								
A2A1R	1" x 14"	Copper Type A	Reinforced SWA						
A2A2R									
A2A3R									
A2A4R									
A2A5R									
Q1N1Q	1" x 12"	SST Type A	SWA						
Q2N1Q	1" x 14"								
G1B2A	1" x 12"								
G2B2A	1" x 14"								
G1B3A	1" x 12"								
G2B3A	1" x 14"								
G1B4A	1" x 12"								
G2B4A	1" x 14"								
G1B5A	1" x 12"								
G2B5A	1" x 14"								
G2B1R	1" x 14"					SST Type A	Reinforced SWA		
G2B2R									
G2B3R									
G2B4R									
G2B5R									
H1B1A	1" x 12"	SST Type B	SWA						
H2B1A	1" x 14"								
H1B2A	1" x 12"								
H2B2A	1" x 14"								
H1B3A	1" x 12"								
H2B3A	1" x 14"								
H1B4A	1" x 12"								
H2B4A	1" x 14"								
H1B5A	1" x 12"								
H2B5A	1" x 14"								
H2B1R	1" x 14"	SST Type B	Reinforced SWA						
H2B2R									
H2B3R									
H2B4R									
H2B5R									
J3T1A	1" x 17"	TFE Coated Type B	SWA						
J3T4A									
J3T5A									

10	Action	
D	Direct	
R	Reverse	

ORDERING SCHEMATIC (CONT'D)

11	Accessories	
	0	None
	2	316SS Bolting
	6	Mtg. Flg. Cu 'C' Bulb
	7	Mtg. Flg. SST 'C' Bulb
	8	Yoke Cover (Flexible Neoprene)
	P	Thermometer in Position 1
	Q	Thermometer in Position 2
	R	Thermometer in Position 3
	S	Thermometer in Position 4
	T	Thermometer in Position 5
	U	Thermometer in Position 6
	V	Thermometer in Position 7
	W	Thermometer in Position 8
	X	Oxygen Clean
	Y	Oil-Free Clean
	Z	Non-Standard

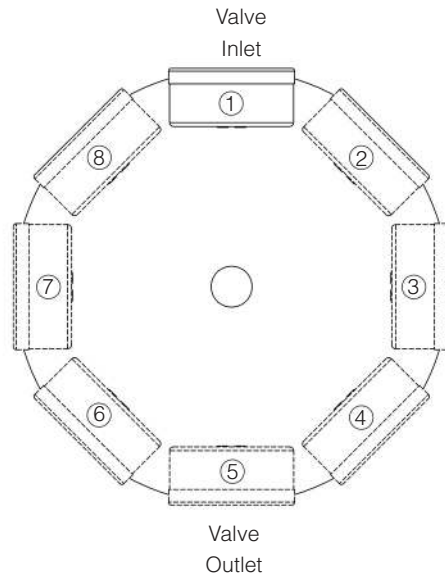

Mark 801/802 Series

Self-Operated Temperature Regulators

Actuator: Type SWA

Capillary Material:

- Standard — Copper
- Optional — SST

Armor/Bulb Material:

- Standard — SST with copper bulb
- Optional — SST with SST bulb; Teflon with Teflon/SST bulb

Capillary/Armor Length:

- Standard — 8 feet
- Optional — lengths to 100 feet

Standard Bulb Dimensions

Bulb Type	Nominal Bulb Size (Diameter x Length) for ranges beginning:	
	101°F (38,3°C) or above	100°F (37,7°C) or below
A & B	1" x 12" (standard) (2,5cm x 30,5cm)	1" x 14" (standard) (2,5cm x 35,6cm)
	3/4" x 23" (optional) (1,9cm x 58,4cm)	3/4" x 27" (optional) (1,9cm x 68,6cm)
C	1" x 12" (SST only) (2,5cm x 30,5cm)	1" x 14" (SST only) (2,5cm x 35,6cm)
	1-1/8" x 14" (CU only) (2,9cm x 35,6cm)	1-1/8" x 14" (CU only) (2,9cm x 35,6cm)
D, E, & F	1" x 12" (2,5cm x 30,5cm)	1" x 14" (2,5cm x 35,6cm)

Types of Bulbs



The MK801/802 Series is completely self-operated and requires no external power source or other expensive instrumentation to operate the valve.

The Mark 801/802 Series is the high-flow and super-high flow versions of our Mark 80 Series temperature regulator.

Accurate temperature control begins with a reliable actuator.

A temperature regulator is only as good as its actuator and a great deal of research has gone into the development of Jordan's stainless steel SWA actuator. That is why the SWA, combined with Jordan's sliding gate regulator design, provides the finest temperature control available in a self-operated design. Among the features of the SWA actuator:

- **Heliarc welded construction:** the upper and lower

SPECIFICATIONS

casings, and diaphragm, are heliarc welded around the circumference to fuse a solid bond and eliminate the need for a gasket, a common source for leakage.

- **Stainless Steel diaphragm:** pre-formed from AISI 347 SST to eliminate rupturing caused by metal fatigue brought about by constant stress, the most common failure in bellows actuators.
- **Sensitive control:** because of the stroke length, the span of an SWA is about 1/3 that of a typical bellows actuator.
- **Simple replacement:** attached to the yoke by just four screws, the actuator can be replaced in less than five minutes (without the need to adjust the stroke after replacement). Control ranges can be changed with the valve in line by simply replacing the actuator.
- **Liquid/vapor thermal system:** to obtain the force needed to position the valve seats, Jordan uses a liquid/vapor thermal system that is capable of delivering far more operating power than the simple liquid expansion systems used on other temperature regulators. As the sensed temperature increases, the liquid fill in the bulb begins to vaporize and creates pressure within the sealed system. This pressure, exerted on the diaphragm, drives the valve stem to modulate the valve seats to the proper position.

FEATURES

- Sliding gate seats provide —
 - Straight-through flow for reduced turbulence and quiet operation
 - Short stroke for fast response and accurate temperature control
 - Easily interchangeable Cv's
 - Tight shutoff due to overlap of seat closure area
- Available with capillaries up to 100 feet (30m) in length.

Line Sizes: 1/2" (DN15) through 2" (DN50)

End Connections:

- Threaded — FNPT, BSPT, BSPP
- ANSI Flanges — 150#, 300#
- DIN Flanges — PN10/16, PN25/40

Body Materials:

- Ductile Iron
- Bronze
- Carbon Steel
- Stainless Steel

Trim Materials:

- 303 SS for DI, BRZ & CS body valves
- 316SS for SS body valves

Seat Materials:

- Jorcote on SST — Standard

Yoke Material: Carbon Iron

Stem Packing Materials:

- Spring-loaded Teflon (to 450°F max/232°C max)
- Braided (above 500°F/260°C up to 650°F/343°C)

Service: steam, water, oil, gas, air and chemicals

Shutoff: ANSI Class IV

Action:

- Direct (increase in temperature closes valve)
- Reverse (increase in temperature opens valve)

Body Rating (Max):

- Ductile Iron: 988 psi @ 100°F; 988 psi @ 450°F (68,1 bar @ 37,8°C; 68,8 bar @ 232,2°C)
- Carbon Steel: 1480 psi @ 100°F; 1235 psi @ 450°F (102,0 bar @ 37,8°C; 85,2 bar @ 232,2°C)
- Stainless Steel: 1480 psi @ 100°F; 990 psi @ 450°F (102,0 bar @ 37,8°C; 68,3 bar @ 232,2°C)
- Bronze: 500 psi @ 100°F; 350 psi @ 450°F (34,5 bar @ 37,8°C; 24,1 bar @ 232,2°C)
- -20°F (-28,9°C) temperature limit on all materials
- For other temperatures, consult factory

Overheat Protection: 100°F (38°C) above top of control range

THERMAL SYSTEM SPECIFICATIONS

Cv Values & Maximum Differential Pressure

- Mark 801

Size		Flow Coefficient		Seat Material	Max ΔP	
Inches	DN	Cv	Kv		PSI	BAR
1/2" & 3/4"	15 & 20	6.4	5,50	SST	75	5,17
				Jorcote	200	13,79
1/2"	15	7.0	6,02	SST	75	5,17
				Jorcote	200	13,79
3/4"	20	9.5	8,17	SST	75	5,17
				Jorcote	200	13,79
1" & 1-1/4"	25 & 32	15	12,90	SST	75	5,17
				Jorcote	175	12,07
1"	25	18	15,48	SST	75	5,17
				Jorcote	175	12,07
1-1/4"	32	25	21,50	SST	75	5,17
				Jorcote	175	12,07
1-1/2" & 2"	40 & 50	30	25,80	SST	75	5,17
				Jorcote	175	12,07
1-1/2"	40	45	38,70	SST	75	5,17
				Jorcote	175	12,07
2"	50	50	43,00	SST	75	5,17
				Jorcote	175	12,07

- Mark 802

Size		Flow Coefficient		Seat Material	Max ΔP	
Inches	DN	Cv	Kv		PSI	BAR
1-1/2"	40	65	55,9	SST	75	5,17
				Jorcote	100	6,89
2"	50	70	60,2	SST	75	5,17
				Jorcote	100	6,89

Available Temperature Control Ranges & Spans

Range °F (°C)	Thermal Fill	Temperature span from closed to open °F (°C) w/standard spring*	
		1/2" - 3/4" (DN15-20)	1" - 2" (DN25-32)
-10 to 20 (-23 to -7)***	Freon 22	18 (10)	30 (17)
20 to 55 (-7 to 13)+	Freon R134A	20 (11)	32 (18)
45 to 90 (7 to 32)+	Iso Butane	21 (12)	33 (18)
65 to 115 (18 to 46)+	N-Butane	21 (12)	33 (18)
90 to 140 (32 to 60)+	Ethyl Chloride	21 (12)	33 (18)
120 to 165 (49 to 74)	Freon R123	31 (17)	38 (21)
130 to 185 (54 to 85)	Ethyl Ether	31 (17)	38 (21)
170 to 225 (77 to 107)	Acetone	31 (17)	38 (21)
215 to 260 (102 to 127)	Isopropyl Alcohol	20 (11)	32 (18)
240 to 290 (116 to 143)	N-Propyl Alcohol	21 (12)	33 (18)
275 to 325 (135 to 163)	N-Butyl Alcohol	21 (12)	33 (18)
325 to 400 (163 to 204)	Xylene	25 (14)	50 (28)
390 to 450 (199 to 232)	P-Cymene	25 (14)	50 (28)

Actuator: Type SWA

Capillary Material:

- Standard — Copper
- Optional — SST

Armor/Bulb Material:

- Standard — SST with copper bulb
- Optional — SST with SST bulb; Teflon with Teflon/SST bulb

Capillary/Armor Length:

- Standard — 8 feet (2,4 meters)
- Optional — Lengths to 100 feet (30,5 meters)

Standard Bulb Dimensions

Bulb Type	Nominal Bulb Size (Dia x Length) for ranges beginning:	
	101°F (38,3°C) or above	100°F (37,7°C) or below
A & B	1" x 14" (standard) (2,5cm x 35,6cm)	1" x 17" (standard) (2,5cm x 43,2cm)
	3/4" x 27" (optional) (1,9cm x 68,6cm)	3/4" x 33" (optional) (1,9cm x 83,8cm)
C	1" x 14" (SST only) (2,5cm x 35,6cm)	1" x 17" (SST only) (2,5cm x 43,2cm)
	1-1/8" x 14" (CU only) (2,9cm x 35,6cm)	1-1/8" x 14" (CU only) (2,9cm x 35,6cm)
D, E & F	1" x 14" (standard) (2,5cm x 35,6cm)	1" x 17" (standard) (2,5cm x 43,2cm)

* Lower spans and ranges available with optional light spring.

** Requires reinforced actuator

+ Requires 1" x 17" bulb

DIMENSIONS

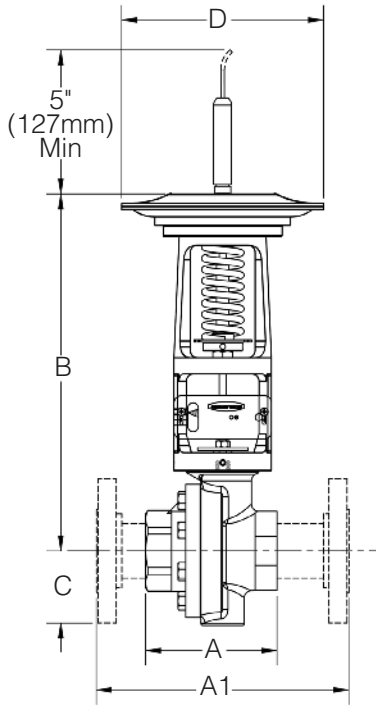

• Flanged Ends

Size	ANSI Flange	Dimensions (inches)				Weight (lbs.)	
		A1	B	C	D	DI/BRZ	CS/SS
1/2"	150#	7.25	12.00	2.18	7.00	21	23
	300#	7.50	12.00	2.18	7.00	22	24
3/4"	150#	7.25	12.00	2.18	7.00	22	25
	300#	7.62	12.00	2.18	7.00	23	28
1"	150#	7.25	12.25	2.62	7.00	24	28
	300#	7.75	12.25	2.62	7.00	25	30
1-1/4"	150#	7.87	12.25	2.62	7.00	25	—
	300#	8.37	12.25	2.62	7.00	26	—
1-1/2"	150#	8.75	12.75	3.00	7.00	29	38
	300#	9.25	12.75	3.00	7.00	31	42
2"	150#	10.00	12.81	3.00	7.00	29	38
	300#	10.50	12.81	3.00	7.00	31	42

• Flanged Ends, Metric

Size (DN)	Flange (PN)	Dimensions (mm)				Weight (kg)	
		A1	B	C	D	DI/BRZ	CS/SS
15	10/16	130	305	55	178	9,5	10,4
	25/40	130	305	55	178	10	10,9
20	10/16	150	305	55	178	10	11,3
	25/40	150	305	55	178	10,4	12,7
25	10/16	160	311	67	178	10,9	12,7
	25/40	160	311	67	178	11,3	13,6
32	10/16	180	311	67	178	11,3	—
	25/40	180	311	67	178	11,8	—
40	10/16	200	324	76	178	12,2	17,2
	25/40	200	324	76	178	13,6	19,1
50	10/16	230	325	76	178	13,2	17,2
	25/40	230	325	76	178	14,1	19,1

• Threaded Ends

Size	Material	Dimensions (inches)				Weight (lbs.)
		A	B	C	D	
1/2" & 3/4"	DI/BRZ	3.62	12.00	2.18	7.00	20
	CS/SS	3.65	12.00	2.18	7.00	21
1"	DI/BRZ	4.12	12.25	2.62	7.00	22
	CS/SS	4.12	12.25	2.62	7.00	23
1-1/4"	DI/BRZ	4.12	12.25	2.62	7.00	22
1-1/2"	DI/BRZ	4.50	12.81	3.00	7.00	24
	CS/SS	5.50	12.81	3.00	7.00	27
2"	DI/BRZ	4.50	12.81	3.00	7.00	24
	CS/SS	5.50	12.81	3.00	7.00	27

• Threaded Ends, Metric

Size (DN)	Material	Dimensions (mm)				Weight (kg)
		A	B	C	D	
15 & 20	DI/BRZ	92	305	55	178	9,1
	CS/SS	93	305	55	178	9,5
25	DI/BRZ	105	311	67	178	10,0
	CS/SS	105	311	67	178	10,4
32	DI/BRZ	105	311	67	178	10,0
40	DI/BRZ	114	325	76	178	10,9
	CS/SS	140	325	76	178	12,2
50	DI/BRZ	114	325	76	178	10,9
	CS/SS	140	325	76	178	12,2

MARK 801/802 SELF-OPERATED TEMPERATURE REGULATORS

ORDERING SCHEMATIC

To specify a MK801/802 Series Temperature Regulator, build a model number by making a selection from each category in the Product Designator Coding System below.

1		2		3	/	4	5	6	7	8	9	10	11	12

1	Model	
	801	High-Flow
	801T	High-Flow with Temperature Gauge
	802	Super High-Flow
	802T	Super High-Flow with Temperature Gauge

2	Size	
	050	1/2" (DN15)
	075	3/4" (DN20)
	100	1" (DN25)
	125	1-1/4" (DN32)
	150	1-1/2" (DN40)
	200	2" (DN50)

3	Body Material	
	DI	Ductile Iron
	BR	Bronze
	CS	Carbon Steel (WCB)
	S6	Stainless Steel (CF8M)

4	End Connections	
	PT	NPT
	BT	BSPT
	BP	BSPP
	SW	FSW
	F1	125# IFE
	I5	150# IFE
	F5	150# FE (except IFE)
	F2	250# FE
	I3	300# IFE
	F3	300# FE (except IFE)
	I7	PN10 DIN IFE
	F7	PN10 FE (except IFE)
	I6	PN16 DIN IFE
	F6	PN16 FE (except IFE)
	I8	PN25 DIN IFE
	F8	PN25 FE (except IFE)
	I4	PN40 DIN IFE
	F4	PN40 FE (except IFE)
	ZZ	Non-Standard

5	Trim	
	T3	303SS / Teflon Packing
	T6	316SS / Teflon Packing
	TM	Monel / Teflon Packing
	TA	Alloy 20 / Teflon Packing
	TH	Hastelloy C / Teflon Packing
	I3	303SS / 287-I Packing
	I6	316SS / 287-I Packing
	IM	Monel / 287-I Packing
	IA	Alloy 20 / 287-I Packing
	IH	Hastelloy C / 287-I Packing
	ZZ	Non-Standard

6	Seats			
	Material		Cv	
	Q	303 / Teflon	K	6.1
	R	316 / Teflon	7	6.4
	S	Monel / Teflon	L	7.0
	T	Alloy 20 / Teflon	M	9.0
	U	Hastelloy C / Teflon	8	9.5
	V	303SS / Jorcote	Q	14
	W	316SS / Jorcote	9	15
	1	303SSSt w/std. W.H.	R	18
	2	316SSSt w/std. W.H.	T	24
			A	25
			B	30
			V	35
			W	45
			C	50
			Y	65
			E	70
			ZZ	Non-Standard

Continued on page 13

ORDERING SCHEMATIC (CONT'D)

7	Range			
	Standard Spring °F		Standard Spring °C	
	08	-10 to 20*	A8	-23 to 7
14	20 to 55	B4	-7 to 13	
23	45 to 90	C3	7 to 32	
30	65 to 115	DD	18 to 46	
37	90 to 140	D7	32 to 60	
47	120 to 165	E7	49 to 74	
52	130 to 185	F2	54 to 85	
60	170 to 225	GG	77 to 107	
68	215 to 260	G8	102 to 127	
75	240 to 290	H5	116 to 143	
84	275 to 325	J4	135 to 163	
90	325 to 400	KK	163 to 204	
95	390 to 450	K5	199 to 232	
ZZ	Non-Standard			
Light Spring °F	Light Spring °C			
	07	-15 to -5*	A7	-26 to -21
13	15 to 35	B3	-9 to 2	
21	40 to 70	C1	41 to 21	
28	60 to 90	C8	16 to 32	
36	85 to 115	D6	29 to 46	
44	115 to 140	E4	52 to 60	
50	125 to 160	FF	46 to 71	
56	155 to 200	F6	68 to 93	
65	205 to 235	G5	96 to 113	
73	235 to 270	H3	113 to 132	
83	270 to 300	J3	132 to 149	
89	320 to 370	J9	160 to 188	

* Reinforced actuator required

8	Thermowell			
	Type, Fitting & Material		Size: for Bulb Diameter x Length	
	A	Type A, 1" NPT, Cu	B	1" x 14" (24,5mm x 355,6mm)
B	Type A, 1" NPT, SST	C	1" x 17" (24,5mm x 431,8mm)	
E	Type B, 1-1/2" x 150#, SST			
F	Type B, 1-1/2" x 300#, SST			
G	Type B, 2" x 150#, SST			
H	Type B, 2" x 300#, SST			
NN	None			
ZZ	Non-Standard			
Tank Fitting Only				
11	1" NPT Brass for 1" Bulb			
12	1" NPT SST for 1" Bulb			
NN	None			
ZZ	Non-Standard			

9	Bulb			
	Type & Material		Diameter x Length	
	A	Type A, Cu	2	1" x 14" (24,5mm x 355,6mm)
G	Type A, SST	3	1" x 17" (24,5mm x 431,8mm)	
H	Type B, SST			
J	Teflon Coated B			
ZZ	Non-Standard			
Type C Bulb				
C9	Type C, Cu		1-1/8" x 14" (28,6mm x 355,6mm)	
C2	Type C, SST		1" x 14" (24,5mm x 355,6mm)	
ZZ	Non-Standard			

10	Capillary / Armor			
	Material		Length	
	A	Cu	1	8' (2,4m)
B	SST	2	10' (3,0m)	
T	Teflon Coated	3	12' (3,7m)	
		4	15' (4,6m)	
		5	20' (6,1m)	
ZZ	Non-Standard			

11	Actuator	
	A	Standard
	R	SWA / Reinforced required below 0°F (18°C)
ZZ	Non-Standard	

12	Action	
	D	Direct
	R	Reverse

Continued on page 14

ORDERING SCHEMATIC (CONT'D)

13	Accessories	
	0	None
	2	316SS Bolting
	6	Mtg. Fig. Cu 'C' Bulb
	7	Mtg. Fig. SST 'C' Bulb
	8	Yoke Cover (Flexible Neoprene)
	P	Thermometer in Position 1
	Q	Thermometer in Position 2
	R	Thermometer in Position 3
	S	Thermometer in Position 4
	T	Thermometer in Position 5
	U	Thermometer in Position 6
	V	Thermometer in Position 7
	W	Thermometer in Position 8
	X	Oxygen Clean
	Y	Oil-Free Clean
	Z	Non-Standard

