

****VIP**** If you purchased your MK96 or MK96C Valve, or any stem repair component for this valve, after 9/17/2018 - please see ****VIP**** assembly instruction change on page 2, middle-right, section 3.



3170 Wasson Road • Cincinnati, OH 45209 USA
Phone 513-533-5600 • Fax 513-871-0105
steriflow@richardsind.com • www.steriflowvalve.com

I & M MK96 & MK96C

Installation & Maintenance Instructions for Mark 96 and 96C Sanitary Pressure Regulators

Warning: Steriflow Sanitary Pressure Regulators must only be used, installed and repaired in accordance with these Installation & Maintenance Instructions. Observe all applicable public and company codes and regulations. In the event of leakage or other malfunction, call a qualified service person; continued operation may cause system failure or a general hazard. Before servicing any valve, disconnect, shut off, or bypass all pressurized fluid. Before disassembling a valve, be sure to release all spring tension.

Please read these instructions carefully!

Your Steriflow product will provide you with long, trouble-free service if it is correctly installed and maintained. Spending a few minutes now reading these instructions can save hours of trouble and downtime later. When making repairs, use only genuine Steriflow Valve parts, available for immediate shipment from the factory.

Ideal Installation

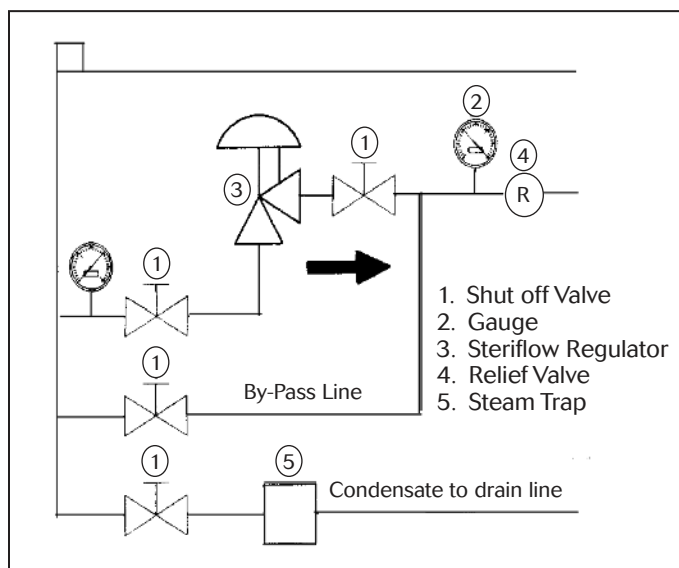

1. The valve is designed for sanitary service and it is assumed that it will be installed into a clean system. It is highly recommended that upstream lines be blown down prior to installation to remove all welding, polishing, and other debris prior to installing the valve.
2. The regulator is to be installed with the inlet vertical, or the bottom, and the outlet horizontal. This will provide the best drainage inside the valve. These restrictions apply only for drainage considerations; the valve will function in any position. Contact factory for other possible orientations.
3. Steam regulators are best located at the highest point in the piping with the take-off out of the top of the steam header. This will minimize the possibility of water in the regulator.

4. For best control, 3' 0" straight sections of pipe should be installed on either side of the regulator.
5. Use caution in tightening commercial sanitary fittings. Over-tightening can cause the gasket to extrude into the flow passage.
6. If possible, install a relief valve downstream from the regulator. Set at about 30% above the control point of the regulator.
7. If you are in gas or vapor service, and your control setpoint is 25% or less than the inlet pressure, you should expand your outlet piping by one pipe diameter for optimal performance.
8. Operate the regulator within its pressure and temperature rating as stamped on the valve nameplate.
9. Steriflow does not recommend using metal seated trim on any service where the flow will be dead-headed downstream of the pressure reducing regulator. Use an appropriate Teflon, Jorlon or Peek seat for the trim instead.
10. It is recommended that you set and test this regulating valve under flowing conditions. Deadheading the valve to measure set point pressure can give faulty readings due to instantaneous pressure creep (opposite of pressure offset or droop).

Start-Up

1. Make sure that the CIP pin (12) is not inserted into the port in the side of the spring housing (14).
2. Fully open the outlet shutoff valve.
3. Slowly open the inlet shutoff valve.
4. Slowly open and close the outlet shutoff valve several times; this will stroke the valve and confirm satisfactory operation.
5. With both shutoff valves open, slowly turn the adjustment screw clockwise to increase the pressure; or counter-clockwise to decrease the pressure.

Maintenance

Caution: Make certain that there is no pressure in the valve before loosening any fittings or joints. The following steps are recommended:

1. Close the inlet shutoff valve.

PROTECT VALVES WITH LINE STRAINERS

2. Allow pressure to bleed off through downstream piping. Do not attempt to reverse the flow through the valve by bleeding pressure from the inlet side.
3. When the pressure gauges indicate that all pressure has been removed from the system, the valve may be serviced.

Note: refer to the drawing at the end of this document for description and proper orientation of parts.

Clean-In-Place

To perform this procedure, the valve is locked in the open position by the CIP pin (12). The pin is attached to the spring housing (14) by a chain. If the valve is open, the pin can be inserted into the port in the side of the spring housing. This prevents the valve from closing and allows cleaning and draining of the internals.

Note: the CIP pin must be removed prior to placing the valve back in service. Otherwise, the valve will not regulate or shutoff, and personal injury or property damage may occur.

Disassembling Valve

3/4" - 1" Mark 96C

1. Insure that the valve is not pressurized by following the **Caution** note at the beginning of the *Maintenance* section.
2. Back off the adjusting screw subassembly (17) to remove the load from the range spring (11).
3. Remove the spring housing (14) by removing the clamp (6).
4. Remove the cylinder (10) from the spring housing (14) by rotating it approximately 90°.
5. Remove the spring (11) and spring guide (13).
6. Remove the hex jam nut (9).
7. Remove the spacer (7), upper diaphragm plate (3), diaphragm gasket (only included on 1/2" - 1" models with a 3-8 psi (0,2–0,5 bar) spring range), and diaphragm (4) from the stem (2). Remove the lower diaphragm plate (26) and o-ring (25) where applicable.
8. Remove the stem (2) from the body (1).

3/4" thru 3" Mark 96

1. Insure that the valve is not pressurized by following the **Caution** at the beginning of the *Maintenance* section.
2. Back off the adjusting screw (17) to remove the load from the range spring (11).
3. Remove the spring housing (14) by removing the hex head cap screws (21).
4. Remove the spring guide (13) and spring (11).

5. Remove the hex jam nut (9) and lockwasher (8) if so required.
6. Remove the cylinder (10) and adapter (31).
7. Remove the spacer (7), upper diaphragm plate (3), diaphragm gasket (only included on 1/2" - 1" models with a 3-8 psi (0,2–0,5 bar) spring range), and diaphragm (4) from the stem (2). **Caution: If the valve is equipped with a metal diaphragm, the edges are very sharp. Exercise care to avoid lacerations.** Remove the lower diaphragm plate (26) and o-rings (25), (30), where applicable.
8. Remove the stem (2) and o-ring (5) [on valves with metal diaphragms only] from the body (1).

Preparing Valve for Assembly

1. All parts should be cleaned and examined. Damaged parts should be replaced.
2. Do not lubricate o-rings
3. For soft seated valves:

****VIP** Use the NEW LOCTITE INSTRUCTIONS below for soft seated valves that meet the following conditions:**

- If you are working on a valve that was purchased after 9/17/2018.
- If you are installing a repair kit for a valve that was purchased after 9/17/2018, and a part number in that repair kit has a model suffix of -SLFLK, -SFLK, or -SLK.

NEW LOCTITE INSTRUCTIONS for valves or parts that meet the above conditions:
Loctite is no longer required for wetted stem component assembly. It can still be used, but its use will make future stem disassembly more difficult.
For valves or parts that don't meet the above conditions use the following instructions:

Clean threads on the stem (2) and on retainer (29) with Loctite primer 7649. Follow Loctite's instructions for Primer and Sealant. Install new soft seat (28) onto retainer (or onto stem when applicable on low flow versions). Apply Loctite Sealant 243 to threads and thread the retainer (29) onto the stem (2). Tighten until the screw threads run out. Allow to cure.

Assembling the Valve

3/4" - 1" Mark 96C

1. Install stem (2) into body (1).
2. When supplied, lubricate o-ring (25) and install into the groove in the lower diaphragm plate (26) for onto stem when applicable on low flow versions. Install lower diaphragm plate (26) onto stem (2).

3. Install diaphragm (4) onto stem (2). Center diaphragm onto body (1).
- 3a) Install diaphragm gasket (only included on 1/2" - 1" models with a 3-8 psi (0,2 -0,5 bar) spring range).
4. Install upper diaphragm plate (3) onto stem (2).
5. Install spacer (7) onto stem (2).
6. Install hex jam nut (9) onto stem (2) and tighten only 1/4 turn. Apply Loctite Primer 7649 and Sealant 243 (following Loctite's instructions) to threads to lock the joint.
7. Install spring (11) into the cylinder (10).
8. Install spring guide (13) onto the spring (11).
9. Lubricate the O.D. surfaces of the cylinder (10) and install the spring housing (14). Rotate the cylinder (10) about 90° to engage the bayonet lugs.
10. Center diaphragm (4) onto body (1). Install spring housing (14) onto the body (1).
11. Secure spring housing (14) to the body (1):
 - Clamped assemblies with two bolts: torque hex nuts (not shown) to 240 inch-pounds (20 foot-pounds).
 - Clamp assemblies with wing nut: torque wing nut (not shown) to 25 inch-pounds (2 foot-pounds).
12. Install thumb-lock (15) onto the adjusting screw (17).
13. Install nameplate onto the adjusting screw (17).
14. Lubricate the threads on the adjusting screw (17) and thread into the spring housing (14). The adjusting screw should engage the hole on the spring guide (13) inside the spring housing (14). Turn the handle clockwise to place a light preload on the spring (11) to hold the parts in place.
15. Attach the CIP pin (12) and the instruction tag to the spring housing (14) using the chain and chain connector.
9. Install lockwasher if so equipped (8), onto stem (2).
10. Install hex jam nut (9) onto stem (2) and tighten. If the valve has elastomer diaphragm, tighten only 1/4 turn and apply Loctite Primer 7649 and Sealant 243 (following Loctite's instructions) to the threads to lock joint.
11. Install spring (11) into the cylinder (10).
12. Install spring guide (13) onto the spring (11).
13. Secure the spring housing (14) to the body (1). Hand tighten the hex head screws (21).
14. Install thumb-lock or hex jam nut (15) onto the adjusting screw (17).
15. Lubricate threads on the adjusting screw (17) and thread into the spring housing (14). The adjusting screw (17) should engage the hole on the spring guide (13) inside the spring housing (14). Turn the handle clockwise to place a light preload on the spring (11) to hold the parts in place.
16. Torque hex head screws (21) to 200 in-pounds (17 foot-pounds).

Troubleshooting

If You Experience Erratic Control:

- Oversizing causes cycling and hunting, and reduces the rangeability of the valve. Make certain that your sizing is correct.
- Steam traps may require maintenance.
- Safety valve may be defective.
- Valve seat in Mark 96 may be defective ~ replace stem (2) and/or body (1).
- Valve plug in Mark 96 may not be moving freely. Inspect bushing (36) and replace if required.

Downstream Pressure Build-Up

- CIP pin (12) may be in place; if so, remove it.
- Valve seat in Mark 96 may be defective ~ replace stem (2) and/or body (1).
- Valve plug in Mark 96 may not be moving freely. Inspect bushing (36) and replace if required.
- Diaphragm in Mark 96 may have failed; replace diaphragm if necessary.
- If Mark 96 is equipped with hard seat, consider replacing with soft seat for tighter shutoff.

Cannot Maintain Regulated Pressure

- Piping may be blocked or inadequately sized.
- Inlet pressure may be set too low.
- Spring may be broken or set too low; check setting; replace spring if broken.
- Valve may be undersized for required flow; make certain that your sizing is correct.
- System demand exceeds pump or boiler capacity.

3/4" thru 3" Mark 96

1. Install stem (2) into the body (1).
2. Install o-ring (5) into the groove into the body (1) (only on valves with metal diaphragm).
3. Install o-ring (25) into the groove on the stem (2). Install lower diaphragm plate (26) onto the stem (2). Install o-ring (30) into the groove in the lower diaphragm plate (26).
4. Install diaphragm (4) onto stem (2). Center diaphragm (4) onto body (1).
5. Install upper diaphragm plate (3) onto stem (2).
6. Install spacer (7) onto stem (2).
7. Center diaphragm (4) onto body (1). *Note: when using the ultra-thin Jorlon diaphragm, gasket P/N 31203-* is to be centered over the diaphragm prior to placing the adapter onto the body.* Install adapter (31) onto body (1). The adapter (31) should engage the pilot diameter on the body (1).
8. Install the cylinder (10) onto the stem (2).

Ordering Spare Parts

Use only genuine Steriflow Valve parts to keep your valve in good working order. So that we can supply the parts, which were designed for your valve, we must know exactly which product you are using. The only guarantee to getting the correct replacement parts is to provide your Steriflow Representative with the valve serial number. This number is located on the valve identification tag. If the serial number is not available, the parts needed for your valve might be determined using the following information: Model Number, Valve Body Size, Seat Material and Cv Rating, Spring Range and Set Point, Trim Material, Part Name - Number and Quantity.

NOTE: Any parts ordered without a valve serial number that are found to be incorrect are subject to up to a minimum 25% restock charge when returned.

Illustration and Parts List

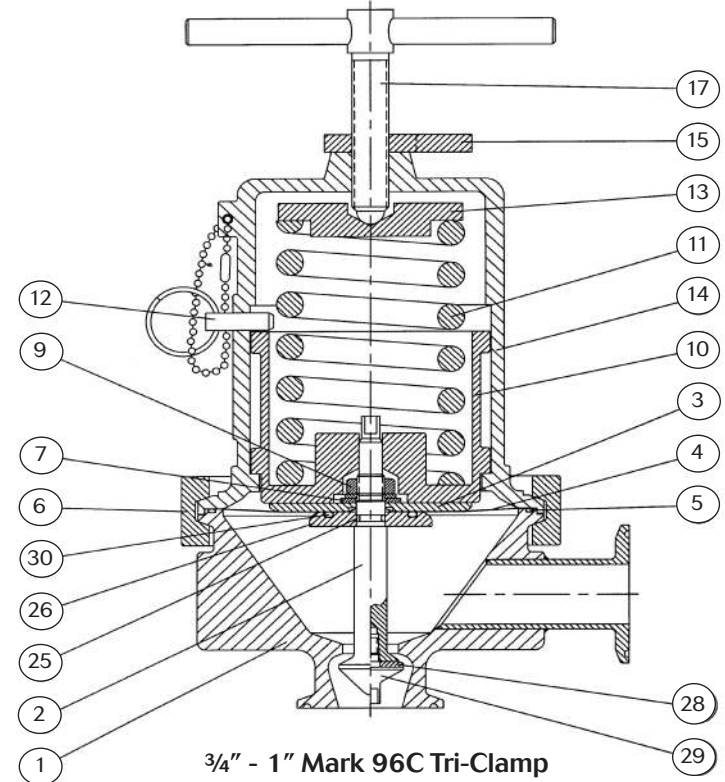
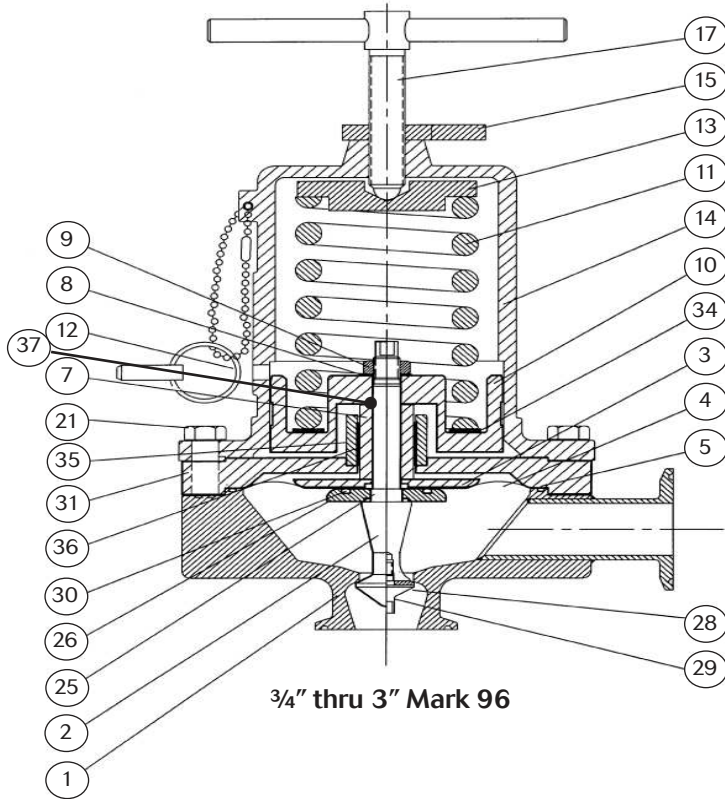

Item	Description	Qty.
1	Body S/A	1
2	Stem	1
3	Upper Diaphragm Plate	1
4	Diaphragm	1
5	O-Ring (if SS diaphragm only)	1
6	Body Tri-Clamp	1
7	Spacer	1
8	Lockwasher	1
9	Hex Jam Nut	1
10	Cylinder	1
11	Range Spring	1
12	CIP Pin S/A	1
13	Spring Guide	1
14	Spring Housing	1
15	Thumblock or Hex Jam Nut	1
17	Adjusting Screw	1
21	HHCS, 3/4" - 1"	8
	HHCS, 1-1/2" & 2"	12
25	O-Ring	1
26	Lower Diaphragm Plate	1
28	Optional Soft Seat	1
29	Soft Seat Retainer	1
30	O-Ring	1
31	Adapter	1
34	Stack-Up Ring	1
35	Gland	1
36	Bushing	1
37	Spacer Shims	2*

Notes: Items 5, 8, and 30 are not required when using an elastomer diaphragm.

Items 5 and 8 are not required when using a Jorlon diaphragm.

* 2 spacer shims are normally provided, but may come with 3.