

S13D SS316 3-piece ball valve - 1/2" up to 4"



Description

- 2-way ball valve with BSP female threaded or BW ends
- Full bore
- Body, ball and stem in SS316
- Mounting flange ISO 5211 for direct mounting pneumatic or electric actuators
- Seats PTFE
- Working pressure maximum 63 Barg
- Temperature -30° up to + 180° C.
- Face to face BSP according to DIN 3203 M4, for But weld ends according to DIN 3202 S13
- Blow-out proof stem, lockable lever
- Anti-static, suitable for vacuum

Options:

- Automatic electric or pneumatic actuation
- Socket weld or NPT female threaded ends
- Stem extension
- Fire safe version according to API607 4e edition
- Spring return lever up to 2"

Certificats:

- 3.1 Material certificate
- CE declaration
- Fire safe according to API607 4e edition
- TA-luft declaration

S13D 1/2 t/m 2"

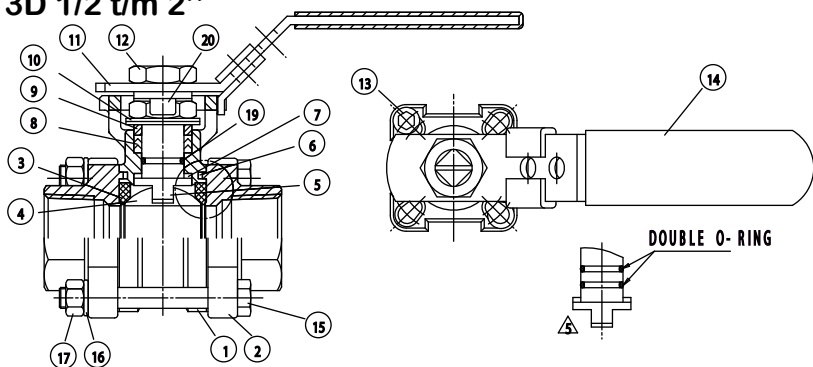

S13D 2 1/2" t/m 4"

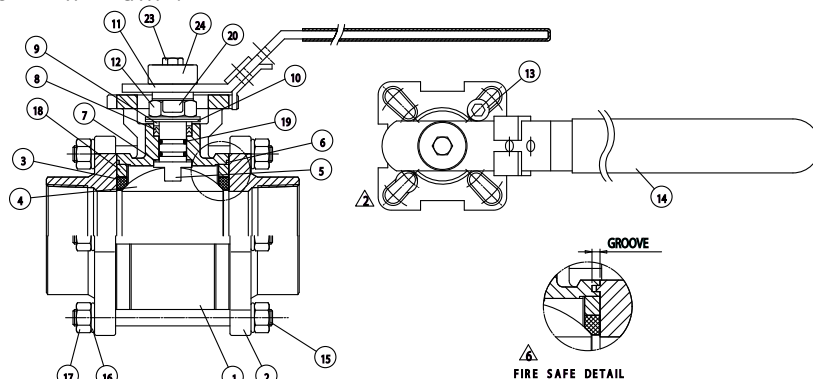

Item	Description	Material	
		Standard	Fire Safe
1	Body	SS316	SS316
2	End cap	SS316	SS316
3	Seat	PTFE	PTFE
4	Ball	SS316	SS316
5	Stem	SS316	SS316
6	Packing	PTFE	Grafiet
7	Seal	PTFE	PTFE
8	Seal	PTFE	Grafiet
9	Gland	SS304	SS304
10	Spring disc	SS	SS
11	Lever	SS	SS
12	Nut	SS	SS
13	Bolt	SS	SS
14	Grip	PVC	PVC
15	Bolts	SS	SS
16	Washer	SS	SS
17	Nuts	SS	SS
18	Center ring	SS	SS
19	O-ring	Viton®	Viton®
20	Locking device	SS	SS
21	Spring	SS316	SS316
22	Ball	SS316	SS316
23	Bolt	SS	SS
24	Washer	SS	

S13D SS316 3-piece ball valve - 1/2" up to 4"

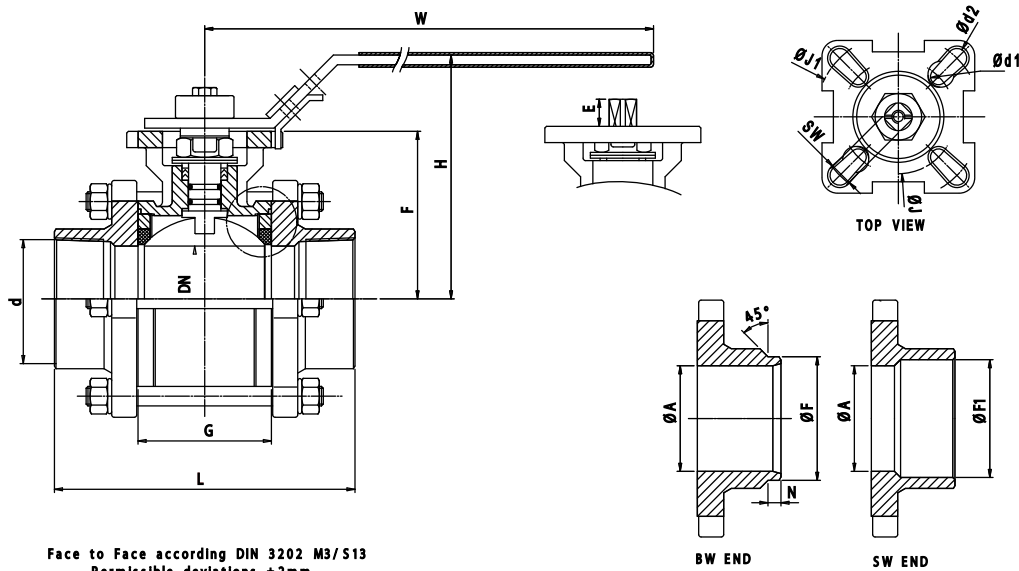
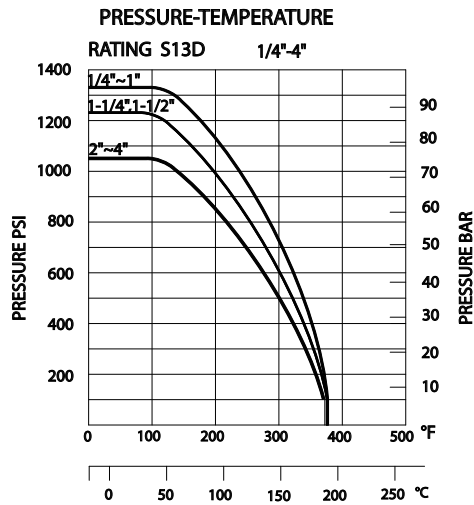

Dimensions 1/2" up to 4" [mm]									
d	1/2"	3/4"	1"	1 1/4"	1 1/2"	2"	2 1/2"	3"	4"
DN	16	20	24.5	32	38	50	65	80	100
L BSP	75	80	90	110	125	150	185	205	240
L-BW	75	90	100	110	125	150	190	220	270
H	70.9	73.4	84.1	98.3	109.5	110.9	155	165	180
W	110	110	135	135	165	165	300	335	335
G ?	25.2	27.7	33	41.2	49.3	63.6	82.1	95.8	117.8
J = ØP-ISO	36	36	42	42	50	50	70	70	70
J1 = ØP-ISO	42	42	50	50	70	70	102	102	102
d1	6	6	6	6	7	7	9	9	9
d2	6	6	7	7	9	9	11	11	11
SW	9	9	11	11	14	14	17	17	17
E	8	8	10	10	14.8	14.8	17.1	17.1	17.1
F	17	22	28	37	43	54	76.1	88.9	114.3
F1	21.3	26.9	33.7	42.4	48.3	60.3	77	90	115.5
Weight [kg]	0.596	0.871	1.359	2.009	2.904	4.669	10.34	15.26	24.6

S13D SS316 3-piece ball valve - 1/2" up to 4"

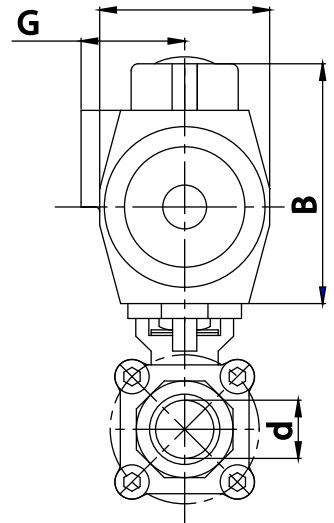
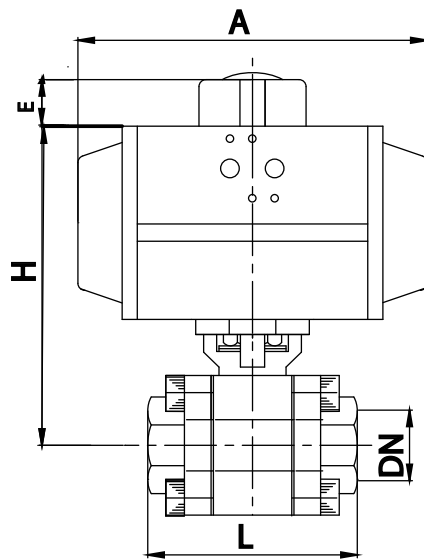

With double acting pneumatic actuator [mm]										
DN (d)	DW	A	B	C	E	G	H	L BW	L BSP	Weight [kg]
DN15 (1/2")	AP1D	137	87	60	20	41	130	75	75	1.5
DN20 (3/4")	AP1D	137	87	60	20	41	132	90	80	1.8
DN25 (1")	AP2D	150	103	73	20	44.5	158	100	90	2.9
DN32 (1 1/4")	AP2D	150	103	73	20	44.5	163	110	110	3.4
DN40 (1 1/2")	AP3D	204	120	85	20	49.5	194	125	120	5.5
DN50 (2")	AP3D	204	120	85	20	49.5	204	150	140	7.1
DN65 (2 1/2")	AP3.5D	230	130	98	20	53	237	190	185	14
DN80 (3")	AP3.5D	230	130	98	20	53	248	220	205	18.7
DN100 (4")	AP4.5D	305	172	128	30	69	305	270	240	33.7

With single acting pneumatic actuator [mm]										
DN (d)	EW	A	B	C	E	G	H	L BW	L BSP	Weight [kg]
DN15 (1/2")	AP2S	150	103	73	20	44.5	146	75	75	2.2
DN20 (3/4")	AP2S	150	103	73	20	44.5	148	90	80	2.5
DN25 (1")	AP3S	204	120	85	20	49.5	175	100	90	4.5
DN32 (1 1/4")	AP3S	204	120	85	20	49.5	180	110	110	5.1
DN40 (1 1/2")	AP3.5S	230	130	98	20	53	204	125	120	7.4
DN50 (2")	AP3.5S	230	130	98	20	53	214	150	140	9.2
DN65 (2 1/2")	AP4S	271	145	110	30	58	252	190	185	16.0
DN80 (3")	AP4.5S	305	172	128	30	69	290	220	205	24.3
DN100 (4")	AP5S	360	185	140	30	-	318	270	240	37.5

Pneumatic actuators are based on PTFE seat rings, minimum air pressure of 6 bar(g) and medium of clean water 20°C with at 6 bar pressure