

S57D 3-way SS316 ball valve - 1/2" up to 2"



Description

- 3-way ball valve BSP female threaded
- Full bore, L- or T port, standard with 4 seat rings
- Body, ball and stem SS316
- Mounting flange ISO 5211 for direct mounting pneumatic or electric actuators
- Seats and seals PTFE
- Blow-out proof stem, lockable lever
- Anti-static
- Working pressure max. 50 barg depending of version
- Temperature -15° C up to 180° C.

Options:

- Automatic electric or pneumatic actuation
- Stem extension
- Endswitches
- Reduced bore
- Spring return lever up to 2"
- Perlast O-rings, Integral seats, Peek seats

Certificats:

- 3.1 Material certificats
- CE declaration

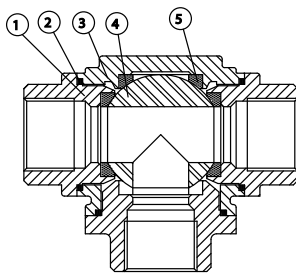
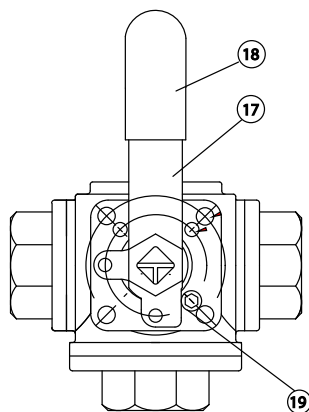
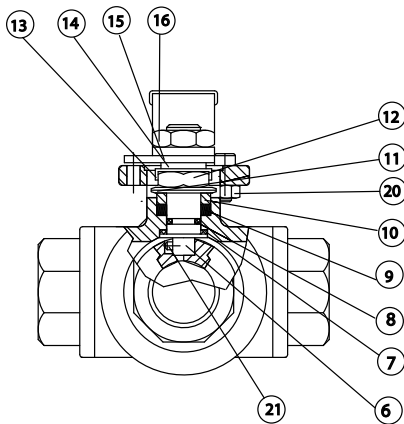

L-PORT 90° TURN

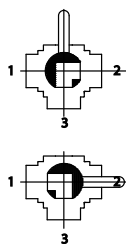

T-PORT 90° TURN

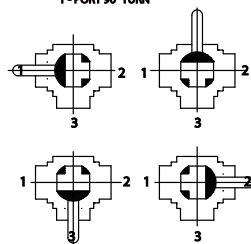

Item	Description	Material
1	End cap	SS316
2	Seal	PTFE
3	Body	SS316
4	Ball	SS316
5	Seats	RPTFE
6	Stem	SS316
7	Thrust washer	PTFE
8	O-ring	Viton®
9	Chevron®	PTFE
10	Gland	SS
11	Disc spring	SS
12	Nut	SS
13	Nut stop	SS
14	Spacer	SS
15	Stop plate	SS
16	Nut	SS
17	Lever	SS
18	Grip	PVC
19	Stop pin	SS
20	Nut	SS
21	Pin	SS

S57D 3-way SS316 ball valve - 1/2" up to 2"

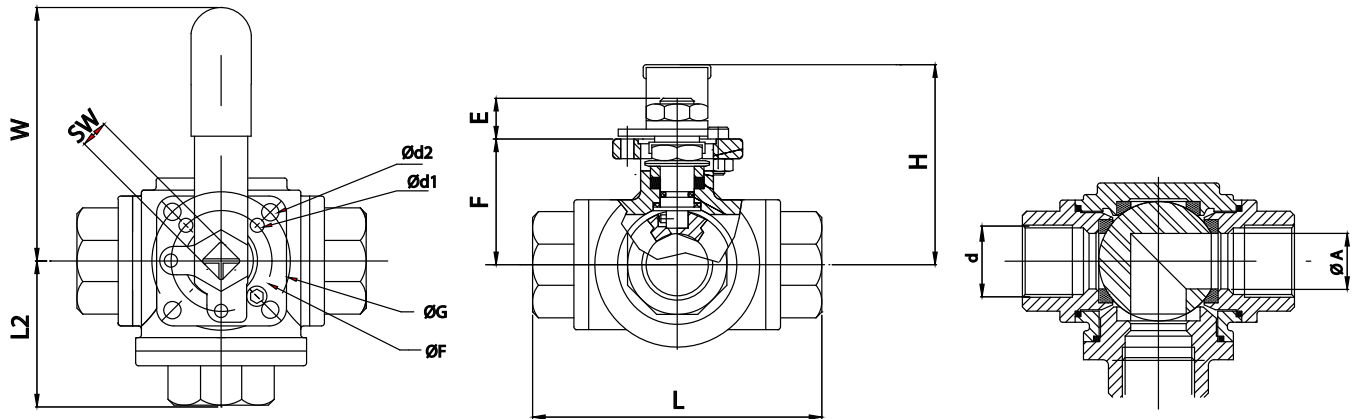

Dimensions 1/4" up to 2" [mm] full bore								
d	1/4"	3/8"	1/2"	3/4"	1"	1 1/4"	1 1/2"	2"
DN	8	10	15	20	25	32	40	50
A	11	12	15	20	25	32	38	50
L	72	72	83	99	112	125	149	174
L2	36	36	41.85	49.5	56	62.5	74.5	87
H	62	62	64	82	89	98	108	140
W	130	130	130	165	165	205	205	325
G	42	42	42	50	50	70	70	102
F	36	36	36	42	42	50	50	70
d1	6.0	6.0	6.0	6.0	6.0	7.1	7.1	9.2
d2	6.0	6.0	6.0	7.1	7.1	9.2	9.2	11.4
SW	9	9	9	11	11	14	14	17
E	11	11	11	14	14	18	18	22
F	37.5	38.5	42	49	55	63	74	93
Weight [kg]	0.66	0.66	0.86	1.48	2.22	3.22	5.36	9.70

Dimensions 1/4" up to 2" [mm] reduced bore						
d	1/2"	3/4"	1"	1 1/4"	1 1/2"	2"
DN	10	15	20	25	32	40
A	12	15	20	25	32	38
L	72	83	99	112	125	149
L2	36	41.85	49.5	56	62.5	74.5
H	62	64	82	89	98	108
W	130	130	165	165	205	205
G	42	42	50	50	70	70
F	36	36	42	42	50	50
d1	6.0	6.0	6.0	6.0	7.1	7.1
d2	6.0	6.0	7.1	7.1	9.2	9.2
SW	9	9	11	11	14	14
E	11	11	14	14	18	18
F	38.5	42	49	55	63	74
Weight [kg]	0.66	0.66	0.86	1.52	2.18	3.38

S57D 3-way SS316 ball valve - 1/2'' up to 2''

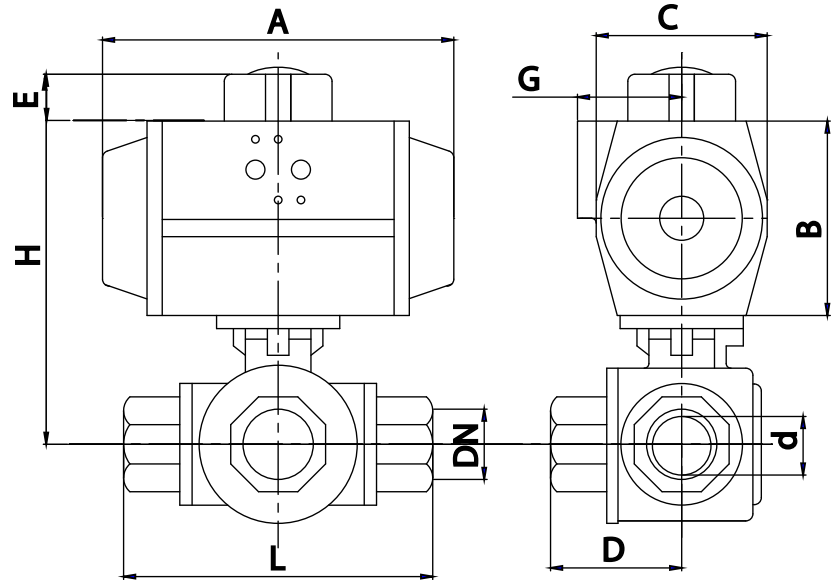

With double acting pneumatic actuator [mm] full bore

DN (d)	DW	A	B	C	E	G	H	L	D	Weight [kg]
DN8 (1/4")	AP1D	137	87	60	20	41	105	72	36	1.6
DN10 (3/8")	AP1D	137	87	60	20	41	106	72	36	1.6
DN15 (1/2")	AP1D	137	87	60	20	41	109	83	41.5	1.8
DN20 (3/4")	AP2D	150	103	73	20	44.5	132	99	49.5	2.8
DN25 (1")	AP2D	150	103	73	20	44.5	138	112	56	3.5
DN32 (1 1/4")	AP3D	204	120	85	20	49.5	163	125	62.5	6.9
DN40 (1 1/2")	AP3D	204	120	85	20	49.5	174	149	74.5	7.9
DN50 (2")	AP3.5D	230	130	98	20	53	203	174	87	13.2

With single acting pneumatic actuator [mm] full bore

DN (d)	EW	A	B	C	E	G	H	L	D	Weight [kg]
DN8 (1/4")	AP2S	150	103	73	20	44.5	121	72	36	2.2
DN10 (3/8")	AP2S	150	103	73	20	44.5	122	72	36	2.2
DN15 (1/2")	AP2S	150	103	73	20	44.5	125	83	41.5	2.4
DN20 (3/4")	AP3S	204	120	85	20	49.5	149	99	49.5	4.5
DN25 (1")	AP3S	204	120	85	20	49.5	155	112	56	5.2
DN32 (1 1/4")	AP4S	271	145	110	30	58	178	125	62.5	9.2
DN40 (1 1/2")	AP4S	271	145	110	30	58	189	149	74.5	11.2
DN50 (2")	AP4.5S	305	172	128	30	69	235	174	87	18.9

Pneumatic actuators are based on PTFE seat rings, minimum air pressure of 6 bar(g) and medium of clean water 20°C with at 6 bar pressure