

Instruction, Use and Maintenance Manual



BY-PASS VALVE

BBZS1- BBYS1

BBWS11

Bardiani Valvole S.p.A.

via G. di Vittorio, 50/52 - 43045 Forno di Taro (PR) - Italy

tel. +39 0525 400044 - fax +39 0525 3408

bardiani@bardiani.com - www.bardiani.com

MANUAL REVISION	DATE

INDEX

1	Safety, Warning and Mandatory Signs	5
1.1	Formazione dell'operatore	8
2	Sicurezza	9
2.1	Precauzioni Generali di Sicurezza	9
3	Technical Data	10
4	Checking / Unpacking / Lifting	11
5	Installation	12
6	Operation	14
7	Troubleshooting	15
8	Cleaning	16
9	Disposal	17
10	Maintenance	18
10.1	General maintenance	18
10.2	Scheduled maintenance	19
10.3	Tools useful for Disassembly/Reassembly	20
10.4	Manual valve BBZS1 - BBYS1	21
10.5	Disassembly of the BBZS1 - BBYS1 - BBWS11	23
A	Disassembly of the BBZS1 - BBYS1	24
B	Disassembly of the BBWS11	32
10.6	Assembly of the BBZS1 - BBYS1 - BBWS11	37
A	Assembly of the BBZS1 - BBYS1	39
B	Assembly of the BBWS11	49
11	Annexes	54
12	2D diagram BBZS1	55
13	2D diagram BBYS1	56
14	2D diagram BBWS11	57
15	Warranty	58
16	Recommendations	59

INTRODUCTION

This "Instruction, Use and Maintenance Manual" has been prepared to provide guidance and recommendations to assist qualified skilled technicians in the understanding, running and maintenance of the Products supplied.

It forms an integral part of the Products supplied and must be read prior to any installation, operation and/or maintenance of all types of valves provided.

This manual must be saved for future reference and be kept readily available at the unit.

With regards to the use of valves compliant with EU Directive 2014/34/UE (ATEX), consultation of a specific manual is mandatory.

The essential characteristics of all types of valves described herein being consistent, the Manufacturer reserves the right to alter and or complement and or update at any time and with no obligation to notify so in writing, the data and or information relevant to the use of the valves described in this "Instruction, Use and Maintenance Manual".





A constantly updated version of this "Instruction, Use and Maintenance Manual" is available at the Manufacturer's website www.bardianivalvole.it.





Under no circumstance shall the Manufacturer be held liable for consequences resulting from failure and or improper use of the instructions contained in this Manual and relating to the installation, operating, maintenance and storage of the products.







All rights reserved.



Full or part reproduction, transfer and or recording of any part of this "Instruction, Use and Maintenance Manual" by all means, whether it be electronic, on hard copy, mechanical or any other means or recording or reuse is strictly prohibited without the prior written consent of the Manufacturer and for any use other than that of the Buyer.









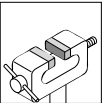
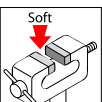

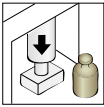
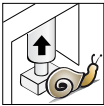
1 Safety, Warning and Mandatory Signs

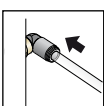
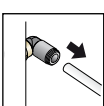
WARNING SIGNS		
Pictogram	Description	Notes
	WARNING General	This tells the person in question that the operation described involves (when not performed in accordance with the relative safety regulations) the risk of personal injury.
	WARNING Hand crushing	Exercise caution in executing the procedure Hand crushing hazard Never touch the moving parts if the actuator is supplied with compressed air.
	WARNING Heavy loads	Exercise caution in executing the procedure Heavy suspended loads.
	WARNING Severe burns	Heat emission hazard Very hot surface, risk of severe burns
	WARNING Risk of explosions	Take Care, risk of explosions

MANDATORY SIGNS (FOR THE OPERATOR IN CHARGE OF ASSEMBLY/DISASSEMBLY)		
Pictogram	Description	Notes
	OBLIGATION General	Special instructions must be followed to avoid injury to persons.
	PROTECTIVE GLOVES	Safety gloves must be available for handling objects which could cause hand injuries.
	HARD HAT	A hard hat must be worn during machine lifting operations to protect against hazards generated by suspended loads.
	FOOTWEAR	Use safety footwear to protect against the risks of falling objects during operations to transport the machine.
	SUITABLE CLOTHING	Suitable clothing such as overalls. It is strictly prohibited to wear clothes with large flapping sleeves and/or other loose items which could easily get caught up in machine parts.

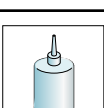
MANDATORY SIGNS (FOR THE OPERATOR IN CHARGE OF MECHANICAL MAINTENANCE)		
Pictogram	Description	Notes
	OBLIGATION General	Special instructions must be followed to avoid injury to persons.
	PROTECTIVE GLOVES	Protective gloves must be available for handling objects which could cause hand injuries or when there is the possibility of coming into contact with harmful substances..
	HARD HAT	Hard hats must be available when lifting heavy parts.
	FOOTWEAR	Use safety footwear to protect against injuries caused by falling objects during maintenance operations (particularly when dismantling parts).
	SUITABLE CLOTHING	Suitable clothing such as overalls. It is strictly prohibited to wear clothes with large flapping sleeves and/or other loose items which could easily get caught up in machine parts.
	SAFETY GLASSES	Protective glasses must be available when there is the possibility of contact which harmful substances which could cause eye injuries.

OPERATING SIGNS		
Pictogram	Description	Notes
	SKILLED PERSONNEL	Dismantling/Assembling and maintenance operations must be carried out by expert technicians only.
	NOTE	Follow the indicated note with care
	ENVIRONMENTAL NOTE	Follow the regulations in force in the country of used governing waste disposal.
	CLAMP	Use of a clamp
	CLAMP WITH SOFT JAWS	Use of a clamp with jaws made from soft material

OPERATING SIGNS		
Pictogram	Description	Notes
	PRESS	Use of a press
	PRESS (release)	Use of a press Gradual release of the pressure force
	ELECTRICAL CONNECTION	Electrical connection to the control unit (consult the relative instruction manual).
	ELECTRICAL DISCONNECTION	Electrical disconnection from the control unit (consult the relative instruction manual).
	PNEUMATIC CONNECTION	Connection of the air to the valve.
	PNEUMATIC DISCONNECTION	Disconnection of the air from the valve
	APPLICATION OF FOODSAFE GREASE	Use FOODLUBE HI-TEMP 2 15254 grease or similar.
	APPLICATION OF FOODSAFE GREASE	Use FOODLUBE Multi-paste 15756 grease or similar.
	APPLICATION OF MULTIPURPOSE GREASE	Use AGIP GREASE MU EP 2 SE 463754 or similar.
	THREADLOCK APPLICATION	Use SPEED BOND M500 threadlock or similar.
	ASSEMBLY / DISASSEMBLY SEQUENCE	Sequence of assembly disassembly operations
	USE HANDS	In all those phases in which this symbol is present, they can use only your hands to unscrew / screw the indicated devices.
	DO NOT USE TOOLS	In all those phases in which this symbol is present, they can't use the tools.
	OPTIONAL	

1.1 Formazione dell'operatore



Tutte le persone che dovranno operare sulla valvola devono avere la qualifica per svolgere le mansioni di manutenzione sulla valvola.

Devono essere informati sui possibili pericoli e devono osservare le istruzioni sulla sicurezza riportate in questo manuale.

Consentire solo a personale qualificato di agire sui componenti elettrici.

2 Sicurezza

2.1 Precauzioni Generali di Sicurezza



Destinazione d'uso

Le valvole Bardiani sono destinate esclusivamente per la movimentazione di fluidi.

Usi non consentiti

Non è previsto utilizzare la valvola:

- per operazioni diverse da quelle descritte al paragrafo "Destinazione d'uso";
- per la movimentazione di fluidi diversi da quelli previsti dal fabbricante e indicate nei dati tecnici della valvola.
- per la movimentazioni di fluidi con pressioni diverse da quelle previste dal fabbricante e indicate nei dati tecnici della valvola.

Limitazioni sull'utilizzo della valvola

E' vietato:

- utilizzare la valvola in una configurazione costruttiva diversa da quella prevista dal fabbricante.
- utilizzare la valvola in luoghi a rischio di esplosione e/o incendio, se non previsto dal fabbricante (in caso di valvole certificate ai sensi della Direttiva 2014/34/UE fare riferimento al Manuale Atex);
- integrare altri sistemi e/o attrezzature non considerati dal fabbricante nel progetto esecutivo;
- utilizzare la valvola per uno scopo diverso da quelli previsti dal fabbricante.



ATTENZIONE

La macchina non può essere utilizzata all'interno di locali con atmosfera a rischio di esplosione o incendio se non previsto dal fabbricante (in caso di valvole certificate ai sensi della Direttiva 2014/34/UE fare riferimento al Manuale Atex).



BARDIANI VALVOLE S.p.A. declina qualsiasi responsabilità per installazione, uso e manutenzione non conformi a quanto previsto dal presente manuale!

3 Technical Data

VALVE DATA	
Maximum pressure	PN10
Storage temperature	From -10°C to 25°C
Material in contact with the product	AISI 316L (1.4404). Check the resistance to corrosion in relation to products and detergents
Gasket material in contact with the product	EPDM, FKM, HNBR, P.T.F.E. and other gaskets on request. Check compatibility with products and detergents
Surface finish in contact with the product	Ra 0.8 µm. Other finishes available on request

STEAM BARRIER DATA	
Connectors	1/8" BSP
Steam maximum temperature	130°C (266°F)
Gaskets material	FKM

GASKET MATERIALS COMPATIBILITY				
Product	EPDM	FKM	HNBR	MVQ
Temperature (applications with air)	From -10 to +140°C	From -10 to +200°C	From -10 to +130°C	From -70 to +230°C
Caustic soda 2%	60°C	30°C	To be checked	Unsuitable
Nitric Acid 2%	60°C	80°C	To be checked	Unsuitable
Saturated steam 125°C	Suitable	To be checked	Suitable	Unsuitable
Greases	Unsuitable	Suitable	Suitable	Unsuitable
Alcohols	Suitable	Unsuitable	Suitable	Suitable



La valvola è conforme alla Direttiva PED 2014/68/UE, con speciale riferimento all' Allegato III, Modulo A riguardante il Controllo di fabbricazione interno come indicato nelle Procedure di Valutazione della Conformità.

Le valvole con DN uguale o inferiore al DN25 non sono comprese conformemente all'Articolo 4 paragrafo 3.

Le valvole destinate a gas, gas liquidi, gas disciolti sotto pressione, vapore e quei liquidi la cui tensione di vapore alla temperatura massima ammissibile è superiore di 0,5 bar alla pressione atmosferica normale (1.013 mbar) sono comprese entro i seguenti limiti:

- le valvole con DN da 32 a 100 (compresi) con fluidi del gruppo 1;
- le valvole con DN uguale o superiore al DN125 con fluidi del gruppo 2.

Si rimanda all'utilizzatore finale l'esecuzione delle prove di emissione acustica una volta avvenuta l'installazione della valvola nello stabilimento di destinazione.

In caso di qualsiasi dubbio di qualsiasi tipo, contattare Bardiani Valvole S.p.A.

4 Checking / Unpacking / Lifting

1. CHECK:

- Check the valve show no signs of damage caused during transport and that it corresponds with the order;
- Check the inside of the valve.



2. UNPACKING:

The valve packaging is made up of cardboard, wood and plastic. The valve is mainly made up of metal materials. The gaskets are usually made from elastomers. The handle in the DN15 - DN100 sizes is made from plastic (POM-C). Disposal must be in compliance with local legislation.

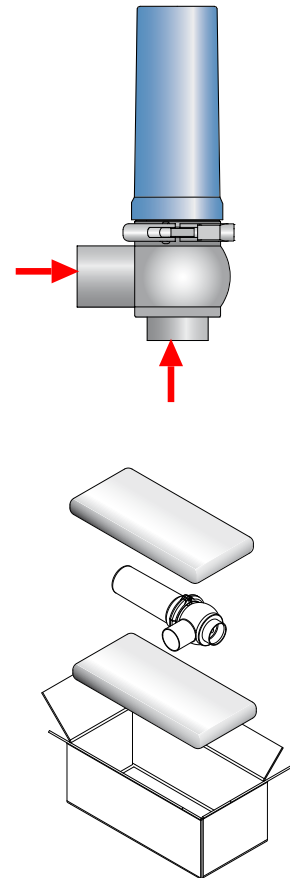

3. VALVE LIFTING:

Take care as to the type of valve you are handling.



CAUTION!

Before lifting the valve, make sure there are no disassembled or separate valve parts which could fall off causing injury to persons and damage to the valve.



CAUTION!

The figures above are used purely to represent the methods and procedures for hoisting the valves. Bardiani Valvole S.p.A. declines all liability for any damage to things and/or injuries to persons caused by improper and/or incorrect hoisting of the valve.

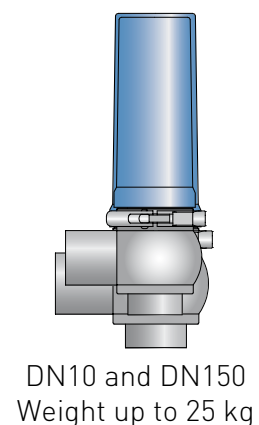

5 Installation



1. PNEUMATIC SUPPLY:

- Use expert personnel for installation/uninstallation operations.



2. REDUCING THE STRESS TO WHICH THE VALVE IS SUBJECTED:

- Vibrations;
- Thermal expansion of the piping;
- Excessive welding;
- Overload.



CAUTION!

The seal seats may become deformed or cause valve malfunctioning.



3. CORRECT DIRECTION OF FLOW:

Flow in the opposite direction to valve closure minimizes water hammer.

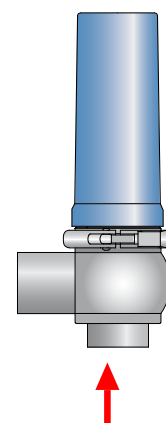
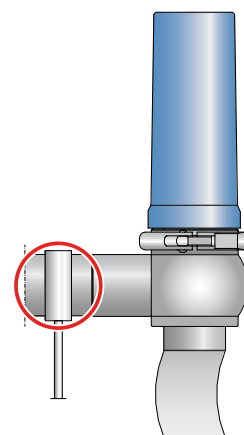

CAUTION!

Bardiani Valvole S.p.A. declines all liability for any damage to things and/or injuries to persons caused by any failure to correctly follow the installation procedures.



4. VALVE CONNECTIONS/CONNECTORS:

If the valve is fitted with connectors, you may proceed with installation. Correctly insert the gaskets and tighten the connectors.

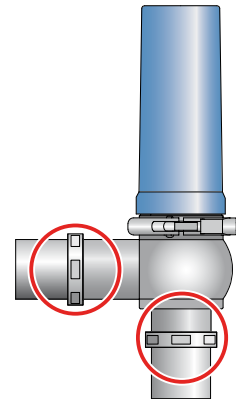

5. WELDING THE VALVE BODY ONTO PIPING:

Remove the body from the rest of the valve before proceeding with welding operations. Please refer to the following pages in this manual.

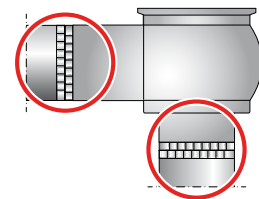

6. MINIMUM MAINTENANCE CLEARANCES:

Make sure there is enough room around the valve for it to be disassembled.

DN	BBZS1 A (mm)	BBYS1 A (mm)
10-25	245	245
32-40	265	265
50	280	280
65	295	295
80	310	310
100	330	330

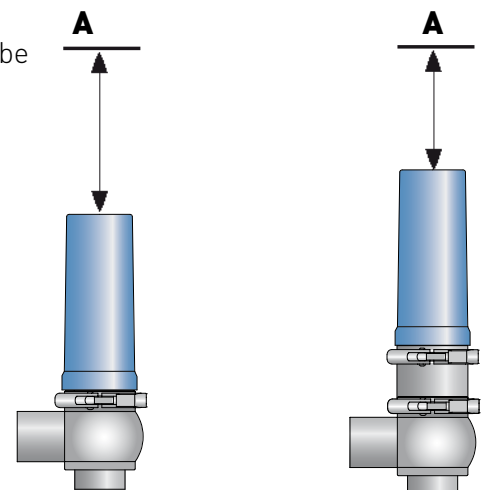

6 Operation



1. PNEUMATIC SUPPLY:

- Use expert personnel for installation/uninstallation operations.

A = Spring compression decrease (lower sealing pressure)

B = Spring compression increase (higher sealing pressure)

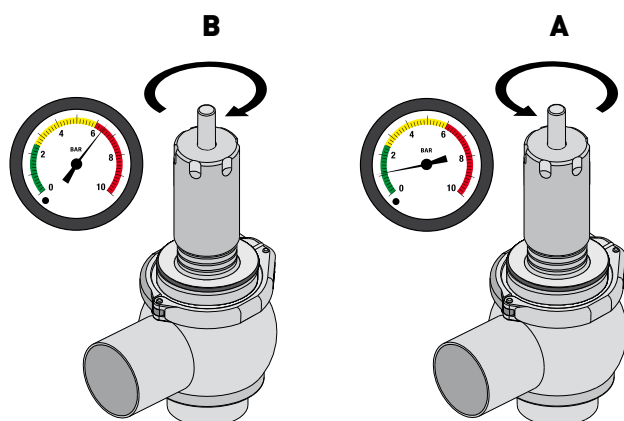

CAUTION!

Bardiani Valvole S.p.A. declines all liability for any damage to things and/or injuries to persons caused by any failure to correctly follow the installation procedures.

7 Troubleshooting



PROBLEM	POSSIBLE CAUSE	POSSIBLE SOLUTION
External leak	Worn gasket	Replace the seal
Leaks inside the closed valve caused by normal wear		
External leak	Excessive pressure	Replace with a gasket of a different type of elastomer
	Excessive temperature	
Premature leaks inside the closed valve	Aggressive fluids	Modify the operating conditions
	Operating conditions	
Difficulty opening and closing	Incorrect valve body positioning. Disassemble and correctly reposition the valve body.	Disassemble and correctly reposition the valve body

8 Cleaning



1. VALVE CLEANING WITH DETERGENTS:

The system in which the valve is installed must be cleaned by expert personnel in observance of the following:

- Abide by the indicated detergent concentration values;
- Observe the instructions provided by the detergent manufacturer.
- Always wear protective safety glasses and gloves.



IMPORTANT!

- Accurately dose detergents to avoid excessive concentration;
- Always rinse thoroughly with clean water after washing.
- Check compatibility of valve materials.

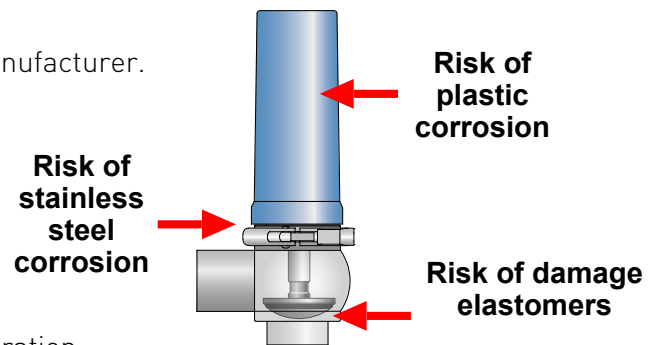

CAUTION!

Burns hazard. The valves and piping may be very hot. Wear protective gloves



WARNING

After installing a new or serviced valve, perform an internal washing cycle before using the piping for food liquids. If there has been any welding work, passivation treatment must be carried out.

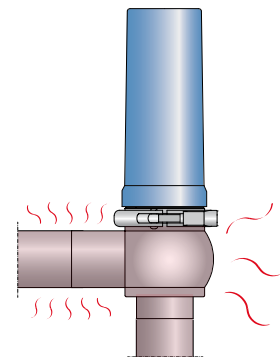

EXAMPLE OF INTERNAL WASHING CYCLE (CIP)

Phases	Temperature °C	Washing product
Initial rinse	Environment	Chlorine- and chloride-free water
Washing	70 °C	Caustic soda (NaOH) at 1%
Intermediate rinse	Environment	Chlorine- and chloride-free water
Washing	70 °C	Nitric acid (HNO ₃) at 0.5%
End rinse	Environment	Chlorine- and chloride-free water

Recommended washing product velocity = 2m/s

9 Disposal



At the end of its service life, the device must be recycled in accordance with the legislation in force in the country of valve use.

Any hazardous residues must be taken into consideration and adequately handled.

The valve is made of AISI 316L and AISI 304 stainless steel, elastomers (gaskets), plastic (control unit) and electrical components (terminal boards, solenoid valves, sensors).

Adhere to the following steps before disconnecting the valve and refer to the heading "General Maintenance".

- make sure the line on which the valve is installed in is not in use
- empty the line on which the valve is installed and clean if necessary
- disconnect the air supply if it is not required during dismantling
- disconnect the valve from the power supply
- remove the valve from the system
- move the valve in observance of the rules set out in the heading "Lifting"
- to dismantle the valve, refer to the heading "Disassembly"

10 Maintenance

10.1 General maintenance



1. MAINTENANCE PRECAUTIONS

Maintenance operations must be carried out by expert technicians only.



CAUTION!

Maintenance operations must be carried out with the line stopped and all utilities (electricity, compressed air) disconnected.

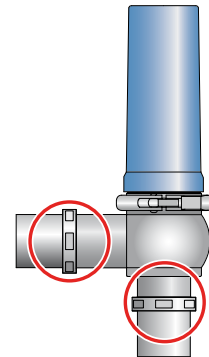

CAUTION!

Always discharge the fluid pressure in the valve and piping before disassembling the valve.



CAUTION!

Burns hazard. The valves and piping may be very hot. Wear protective gloves

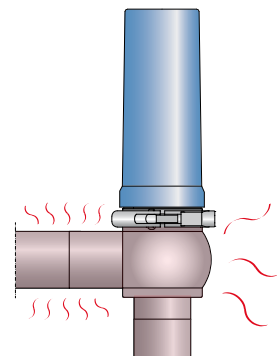



2. CLEANING AWAY DEPOSITS:

- Thoroughly wash and clean all the valve parts before disassembly;
- Pay attention to any possible detergent or other aggressive fluid deposits (see "Cleaning");
- Always use protective safety glasses and gloves when required.

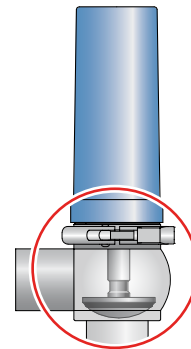

3. SOSTITUZIONE PARTI USURATE DELLA VALVOLA:

Utilizzare sempre ricambi originali.

10.2 Scheduled maintenance

SCHEDULED MAINTENANCE	VALVE GASKETS
Preventive	Replace after 12 months
In the event of leaks	Replace at the end of the day
Periodical	Check correct operation and that there are no leaks
	Record the actions carried out

10.3 Tools useful for Disassembly/Reassembly

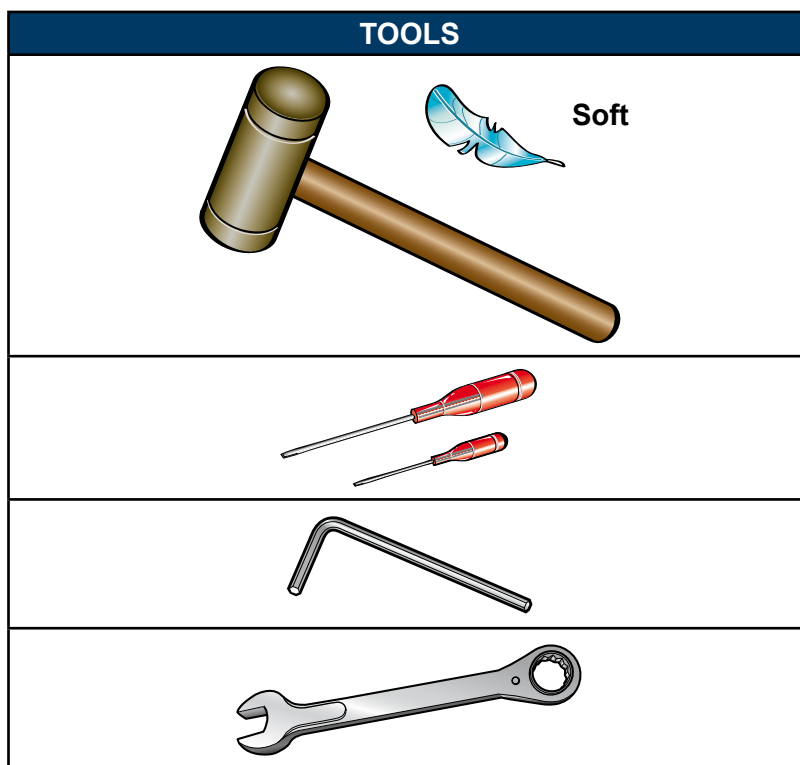

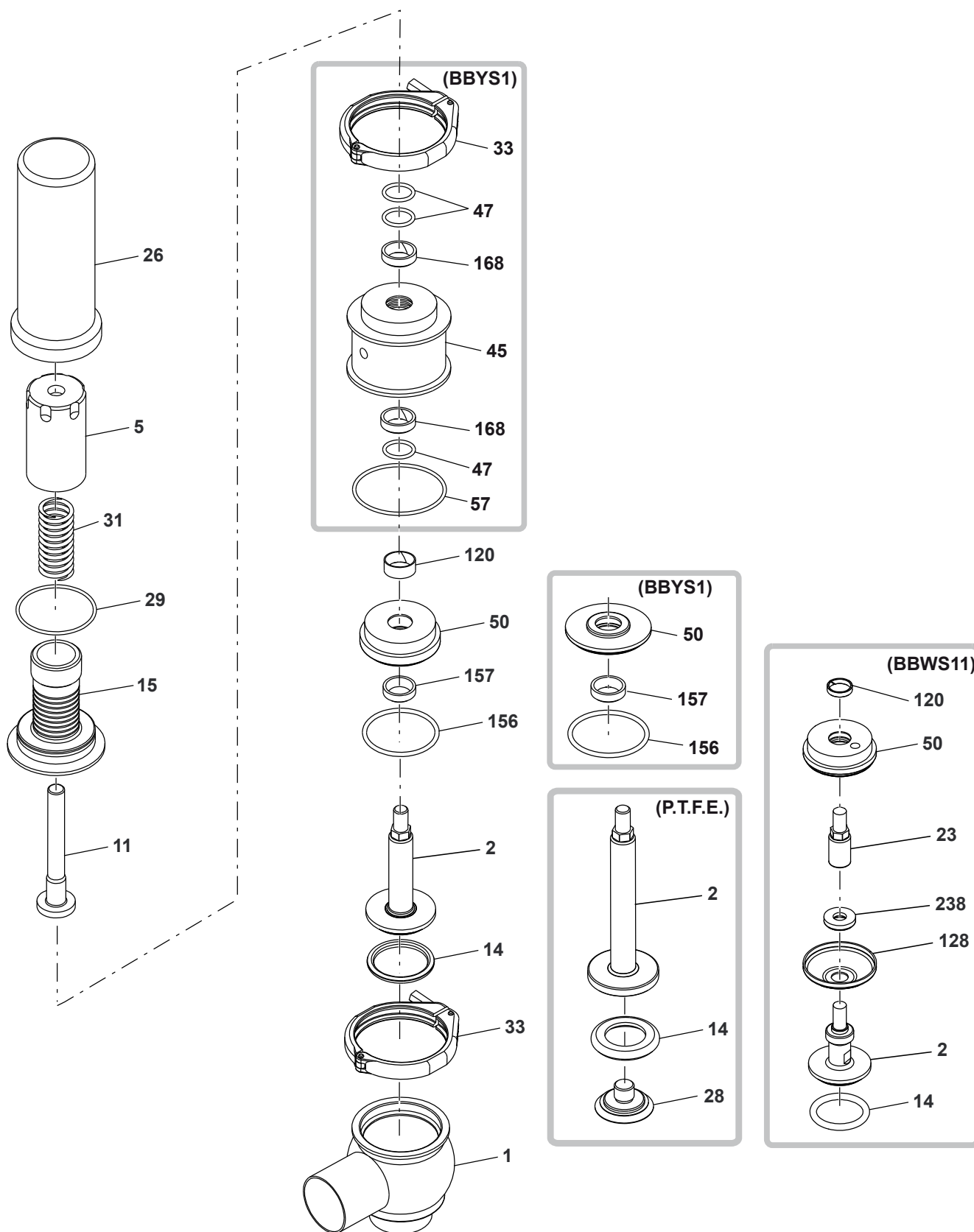

10.5 Disassembly of the BBZS1 - BBYS1 - BBWS11

A

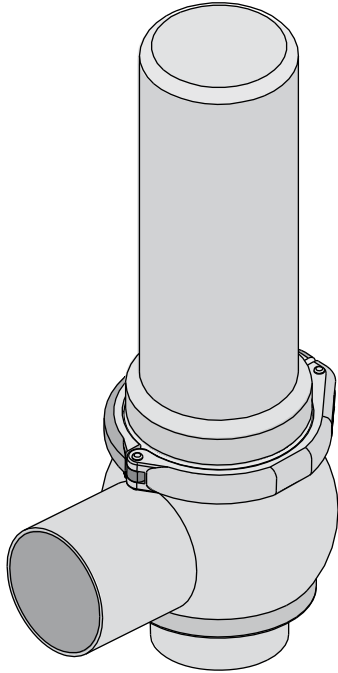

[A S BBZS1]

B

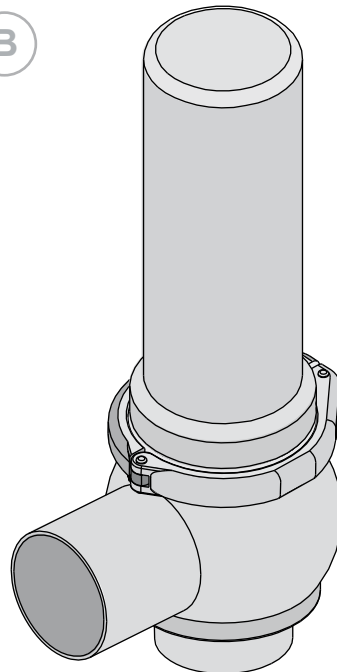

[B S BBWS11]

A Disassembly of the BBZS1 - BBYS1

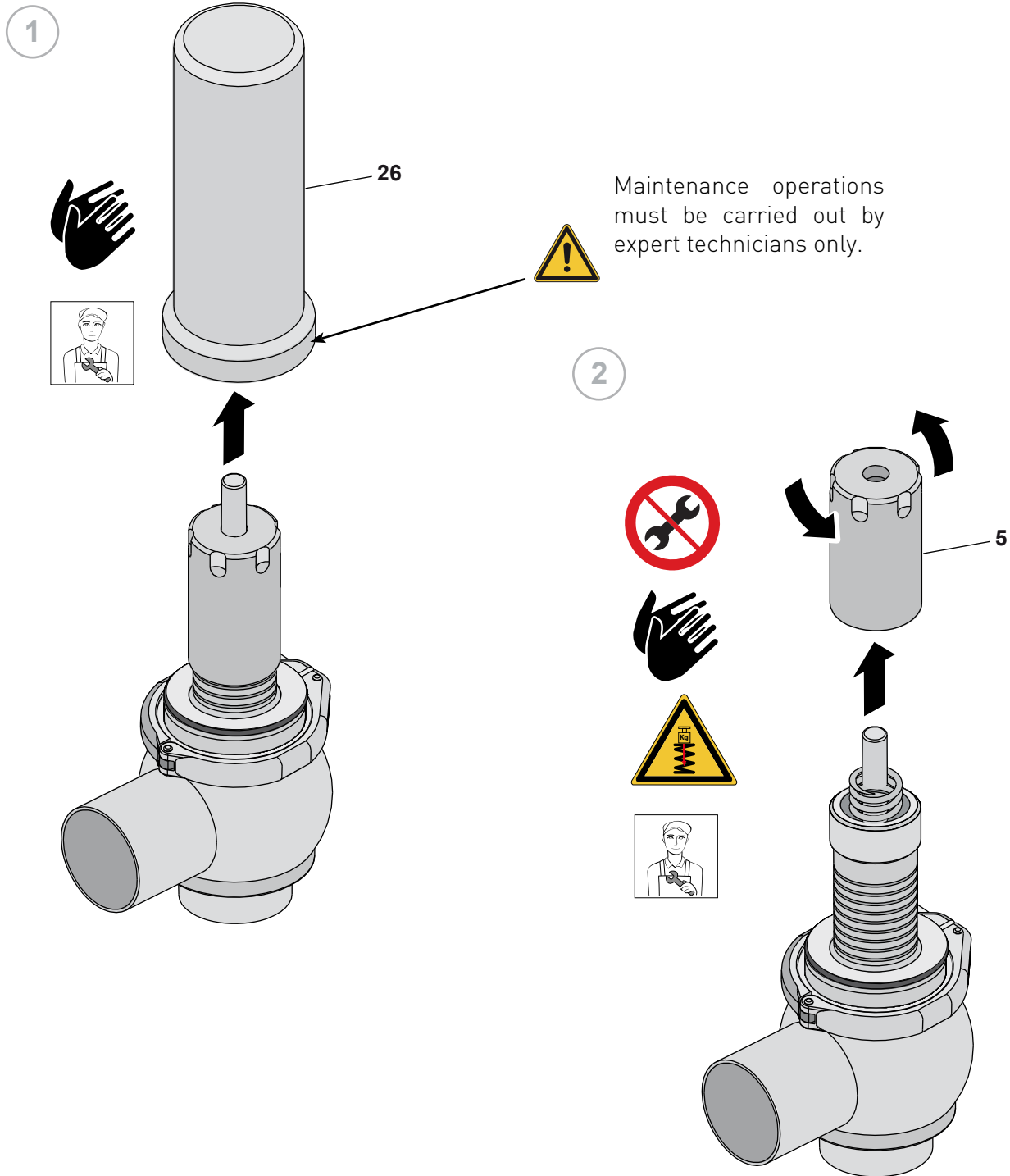

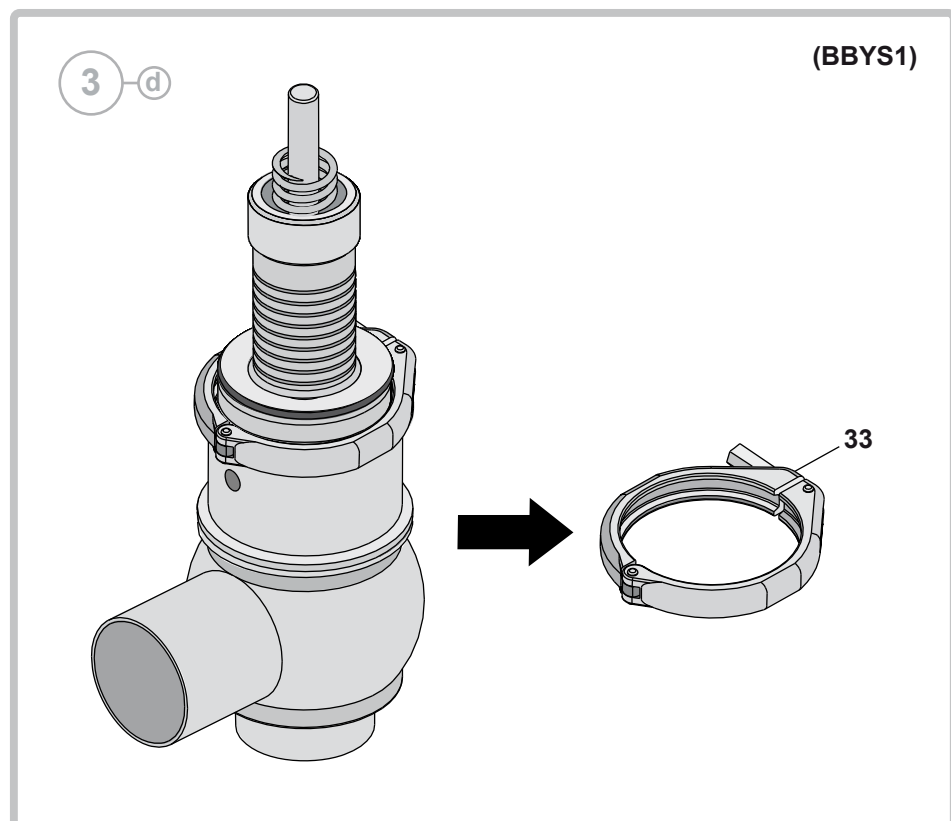
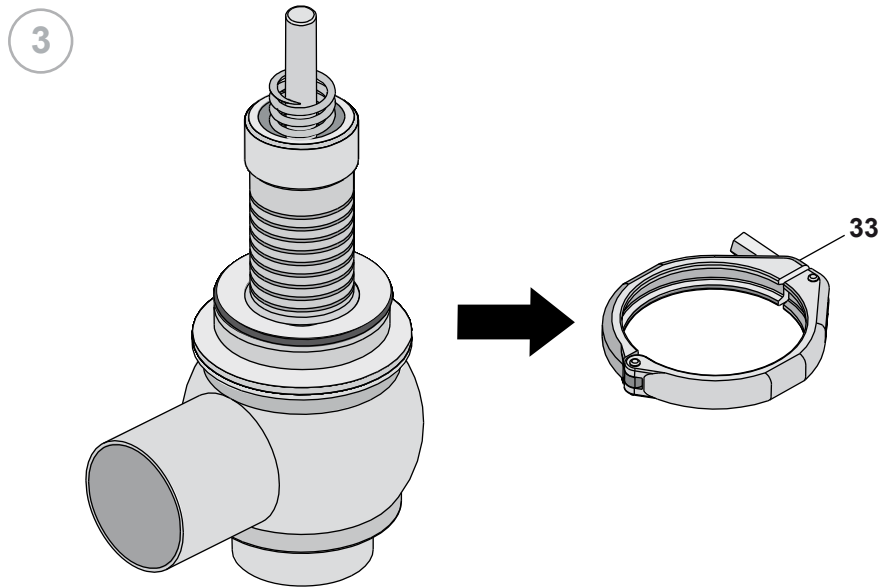

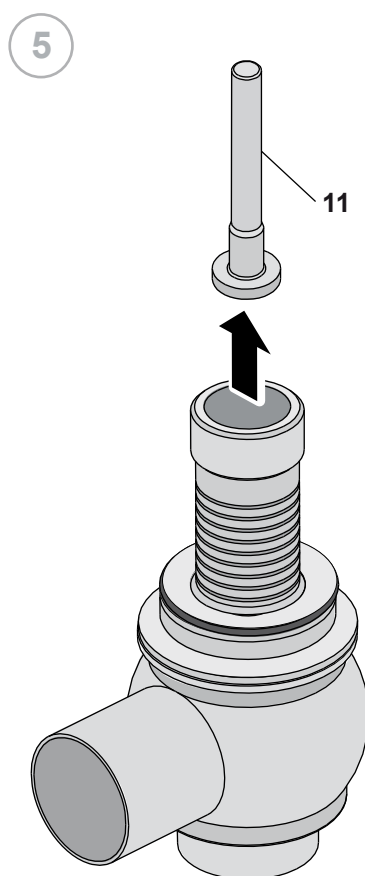
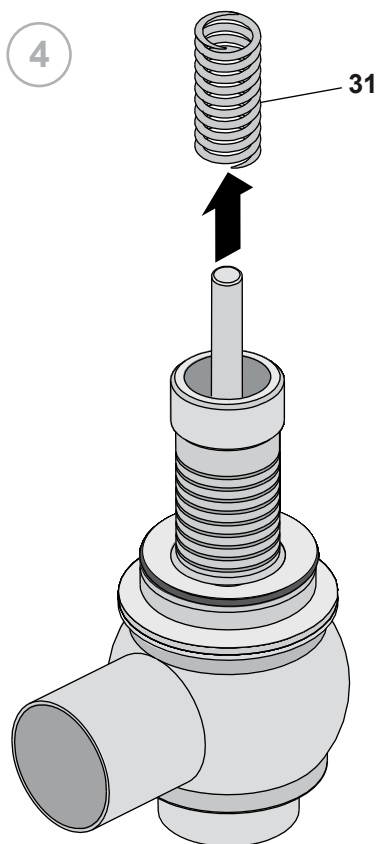

BBZS1

6 a

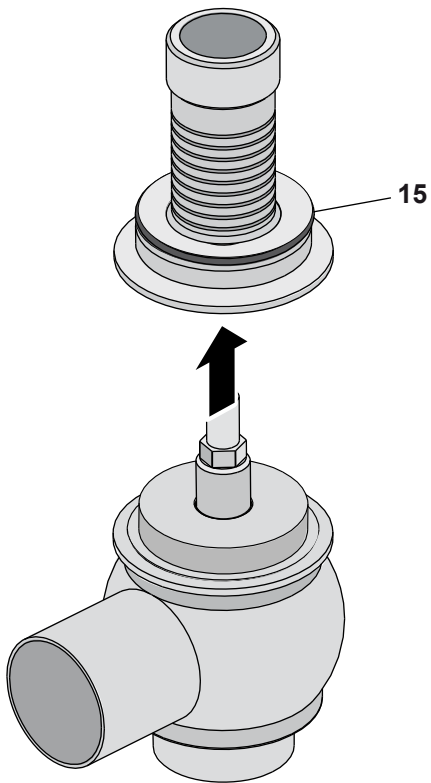

7 a

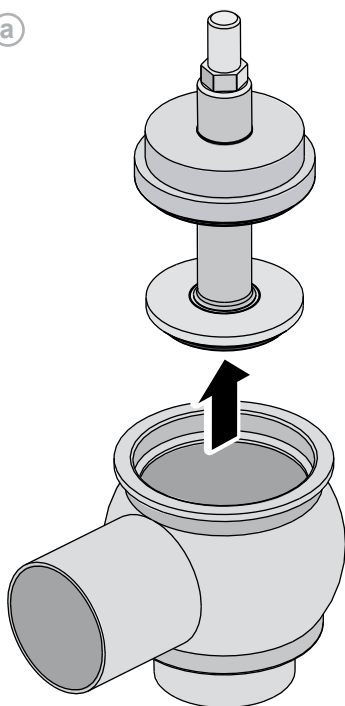

BBYS1

6 d

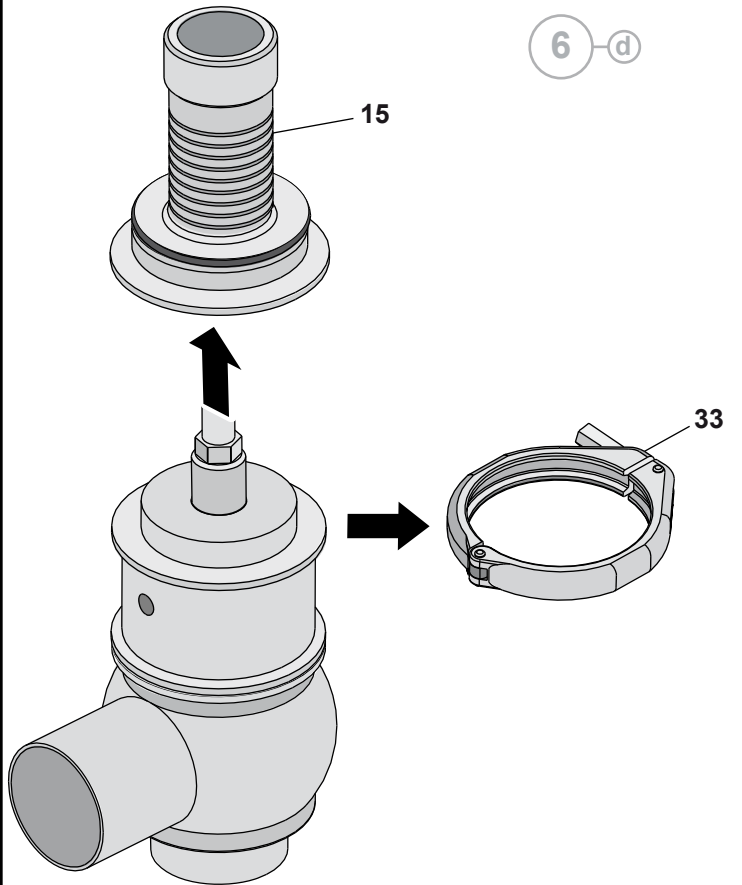

7 d

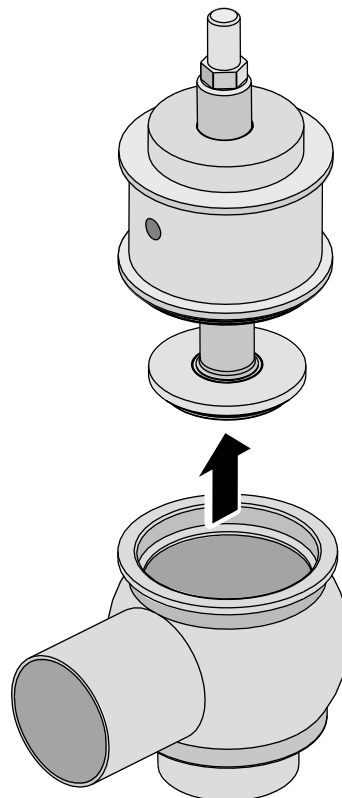

BBZS1

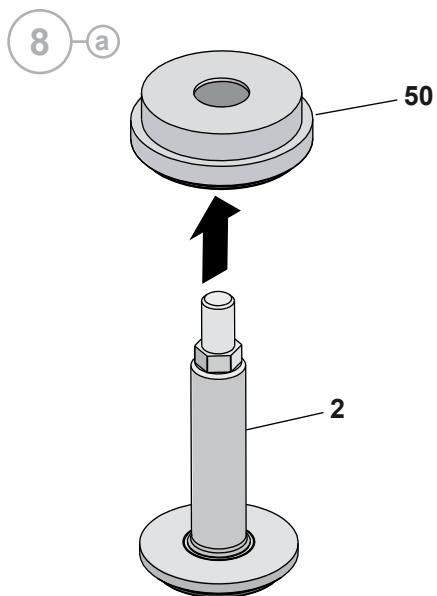

BBYS1

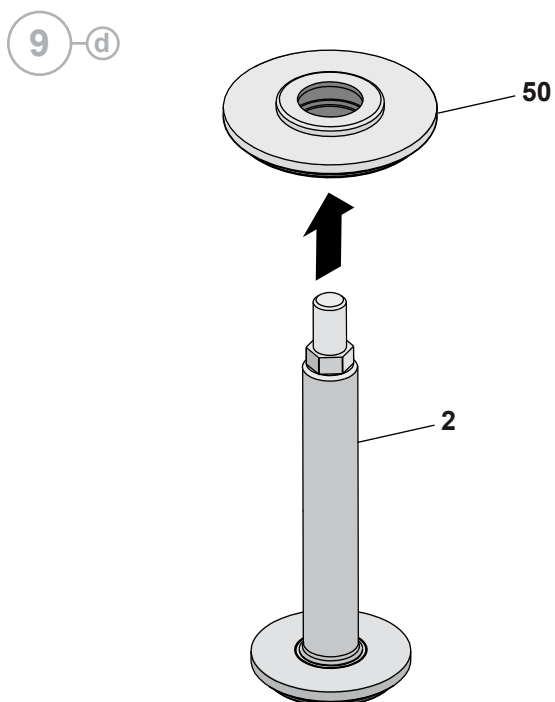
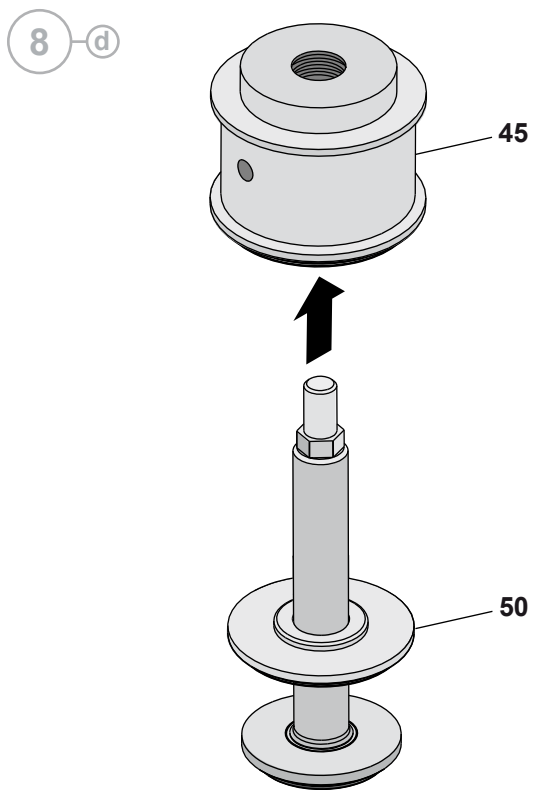

BBZS1

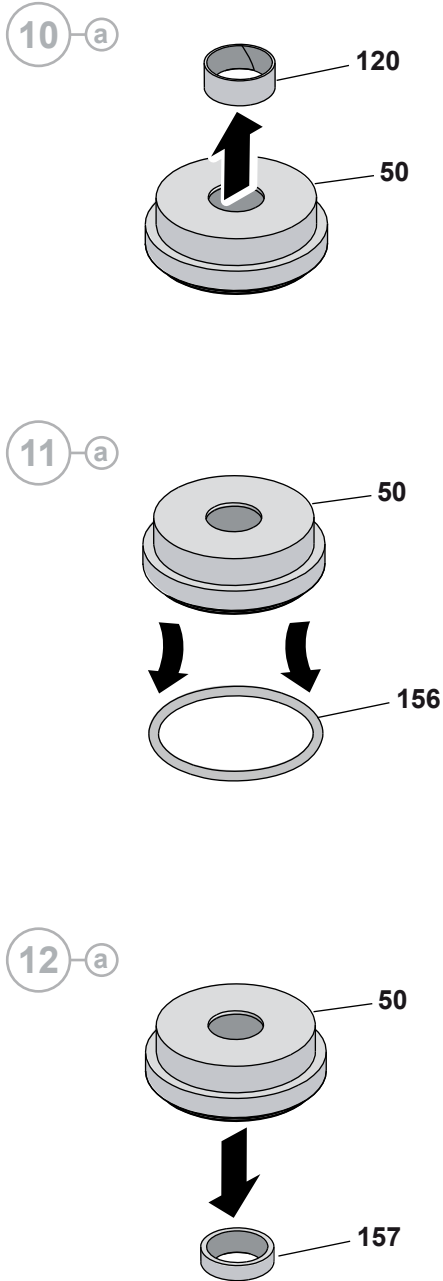

BBYS1

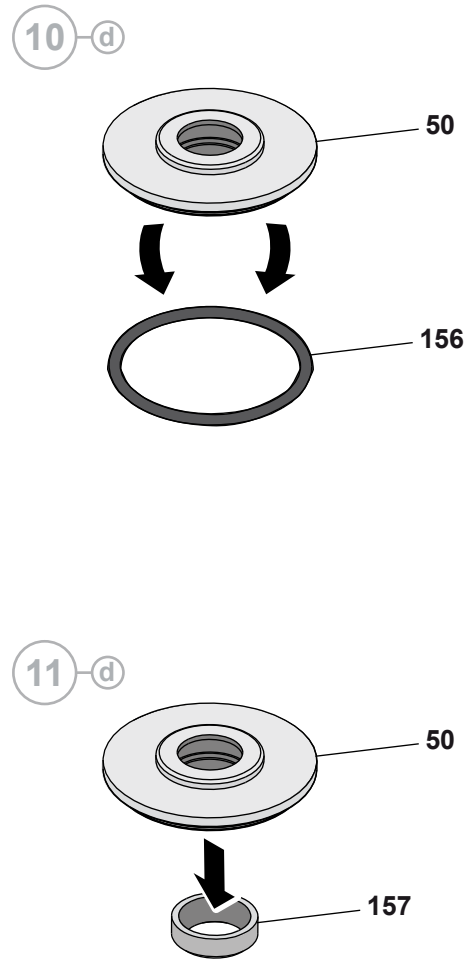

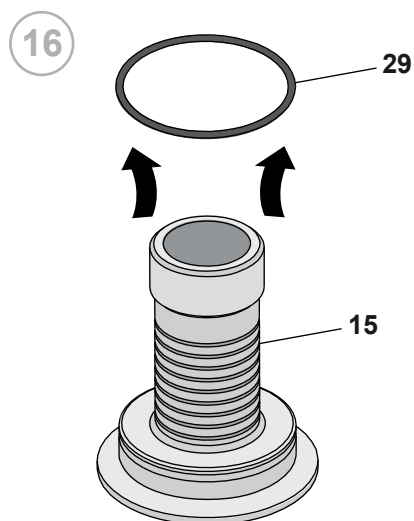
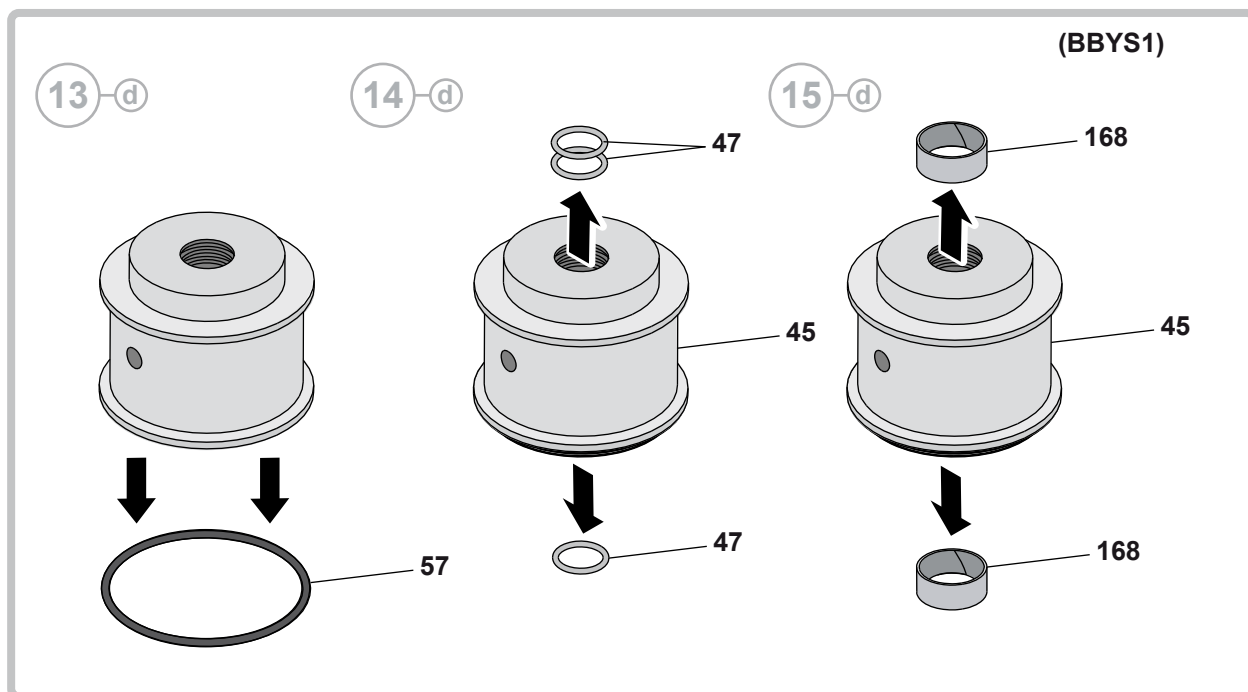

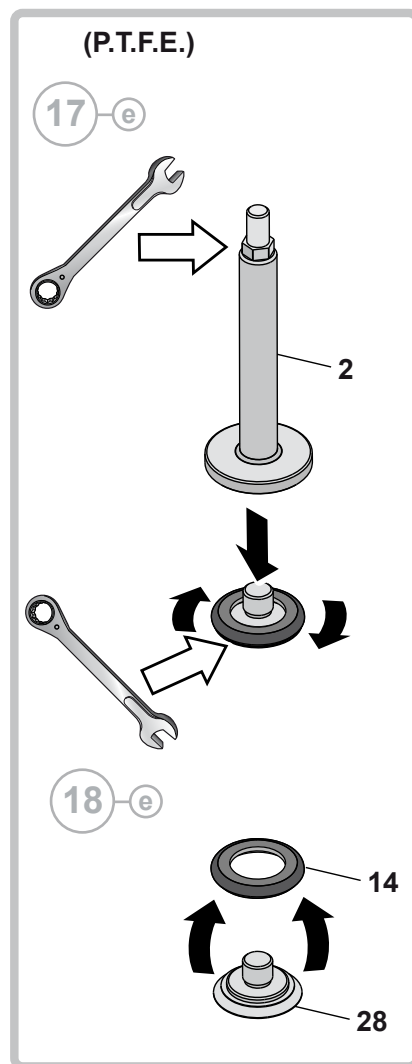
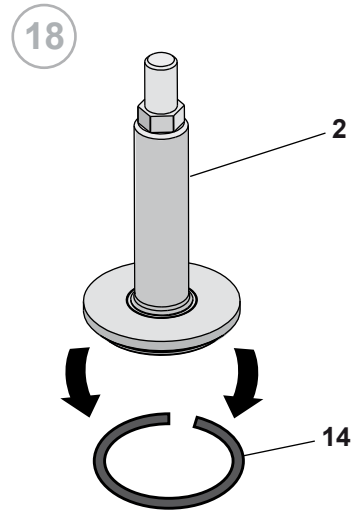
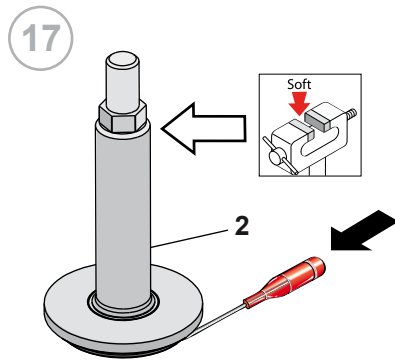

B Disassembly of the BBWS11

1

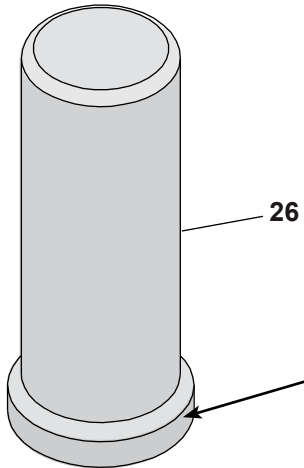

Maintenance operations must be carried out by expert technicians only.

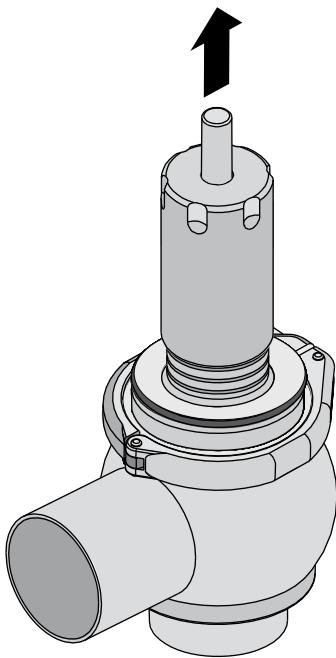

2

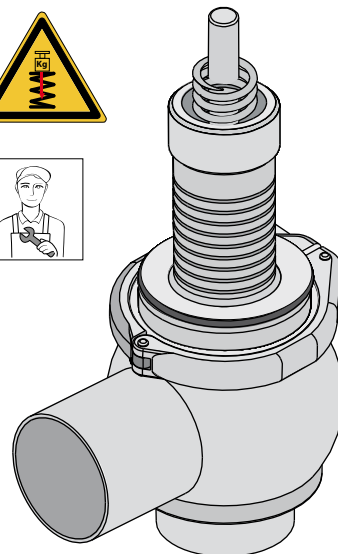
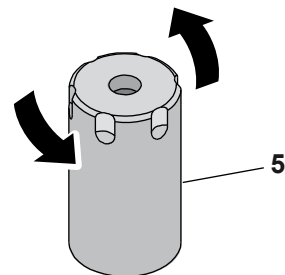

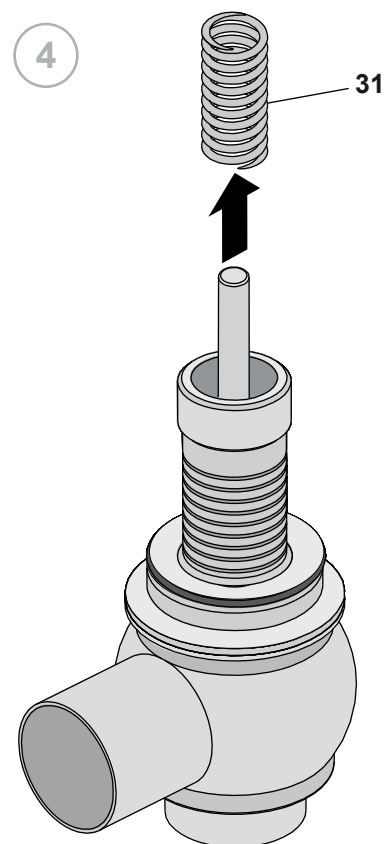
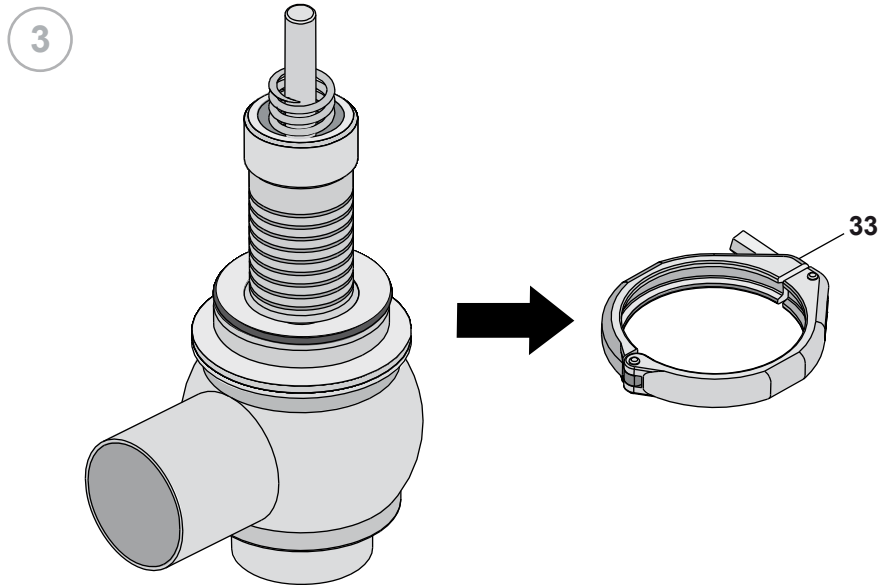

5

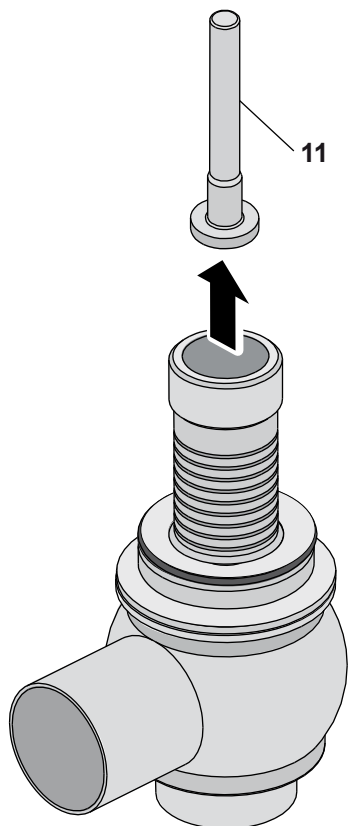

6

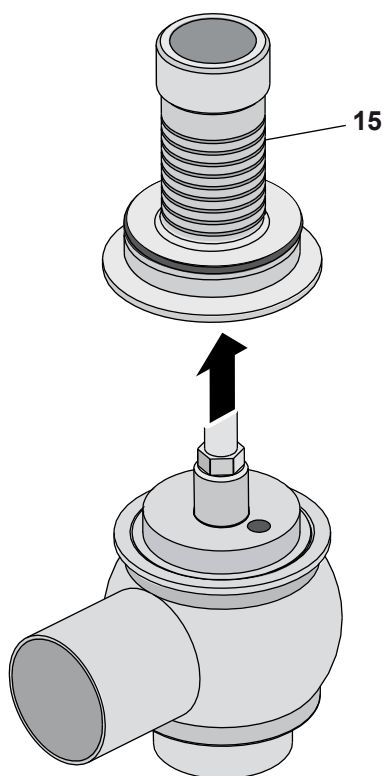

7

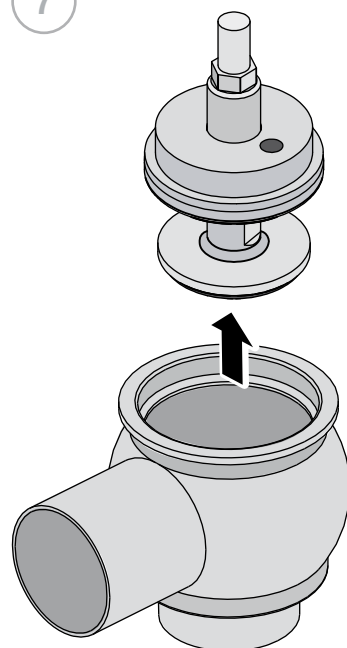

8

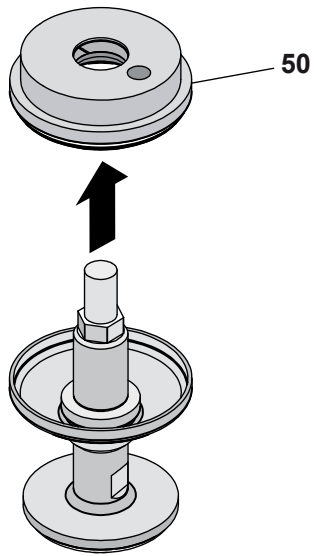

9

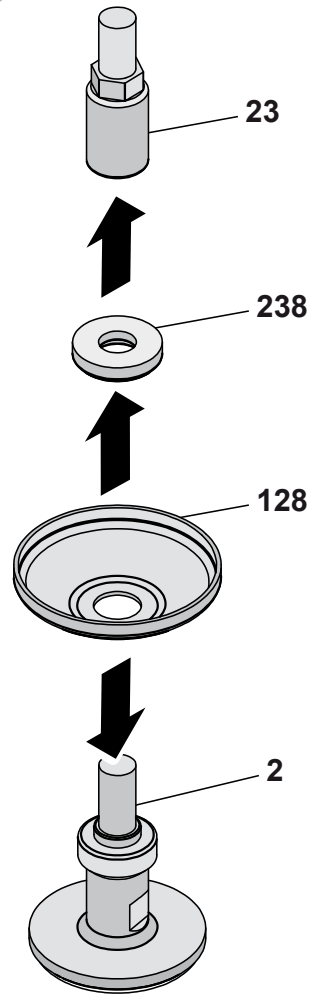

10

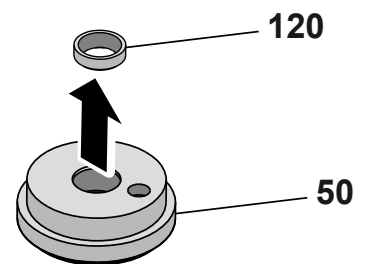

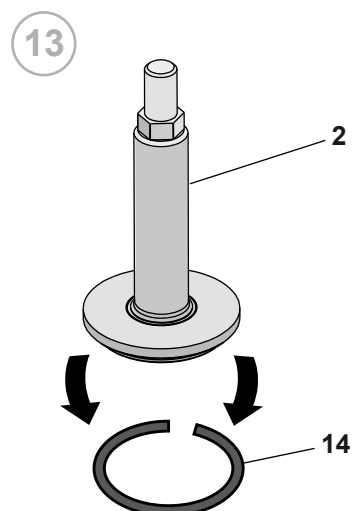
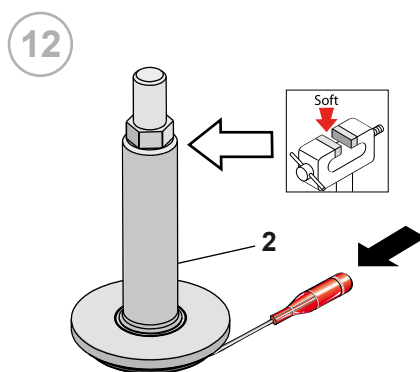
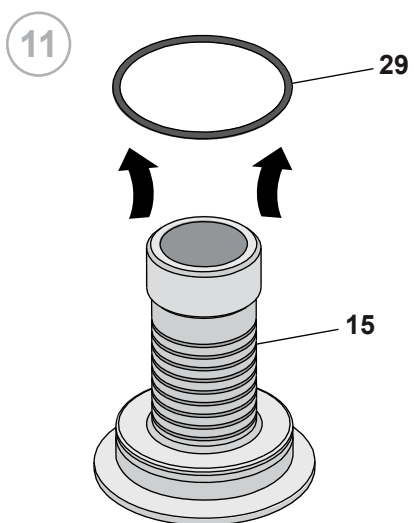

10.6 Assembly of the BBZS1 - BBYS1 - BBWS11

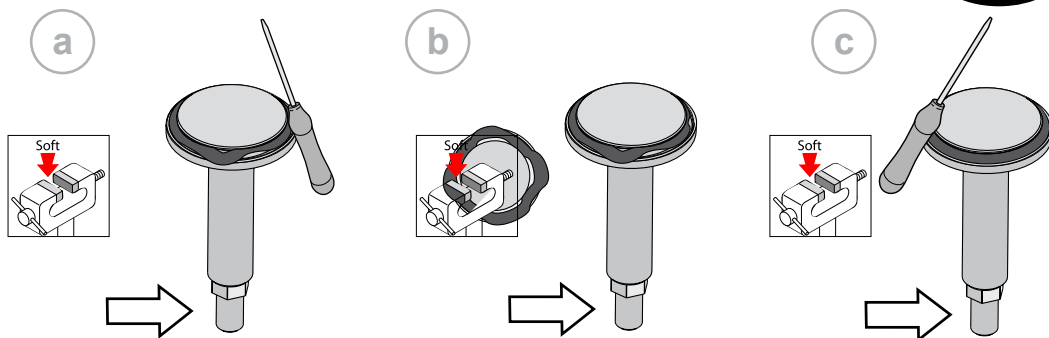
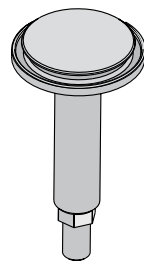
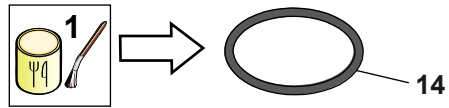

A

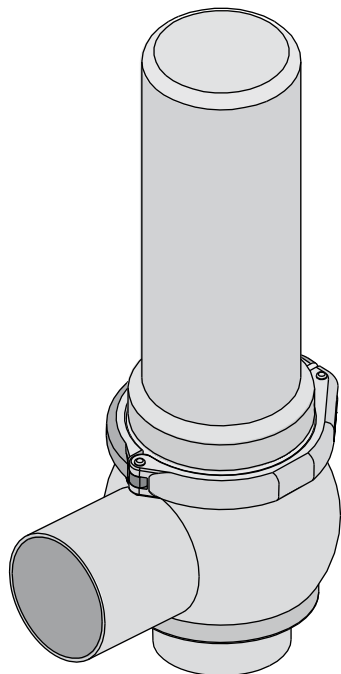

[A M BBZS1]

B

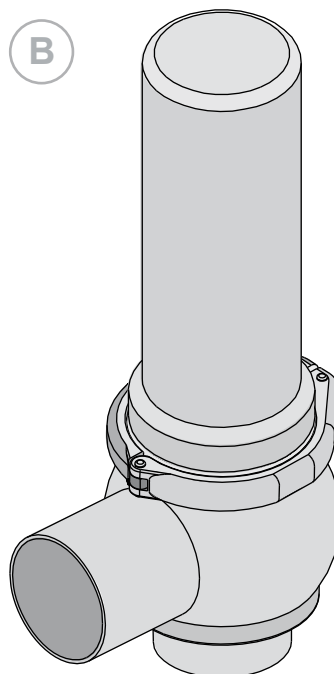

[B M BBWS11]

A Assembly of the BBZS1 - BBYS1

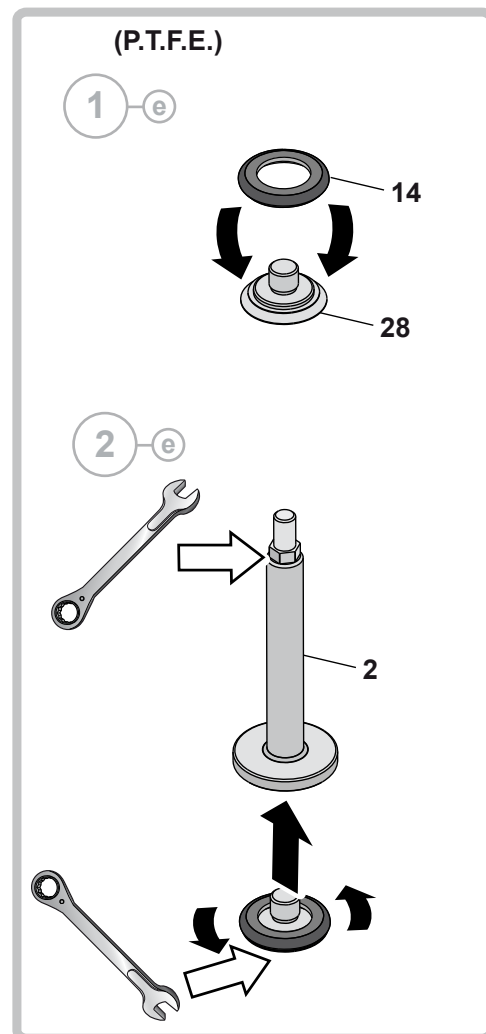
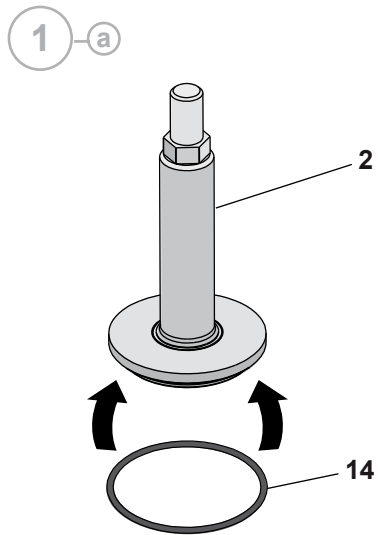

BBZS1

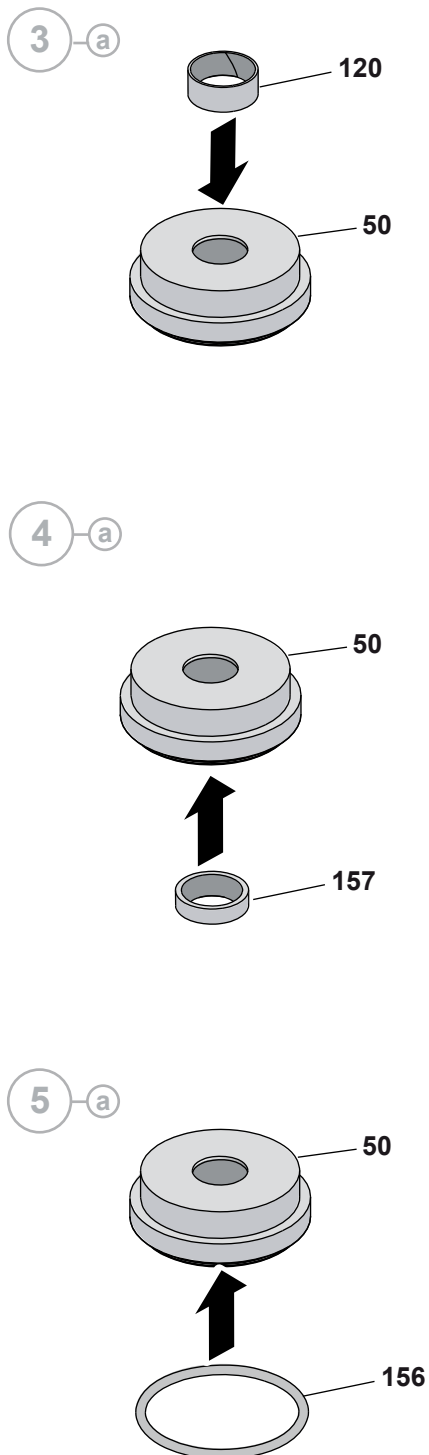

BBYS1

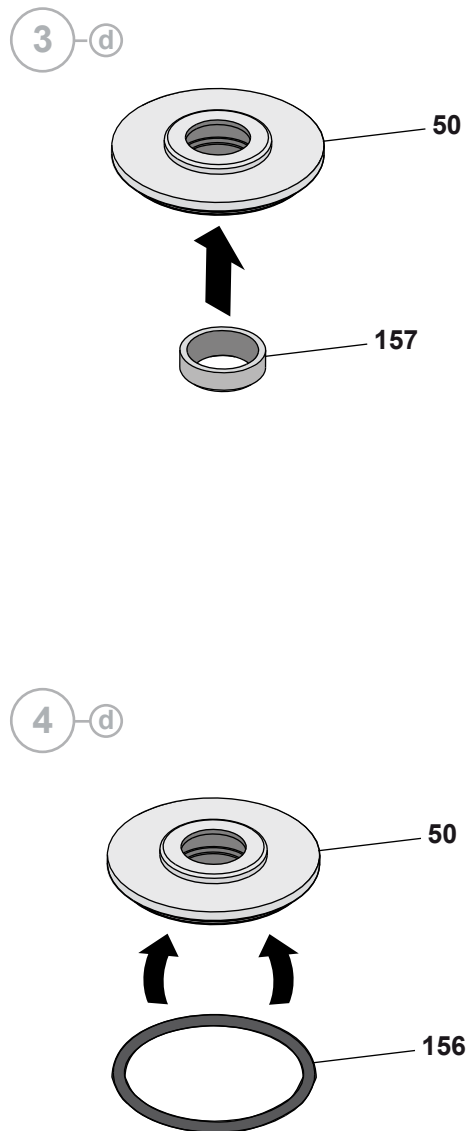

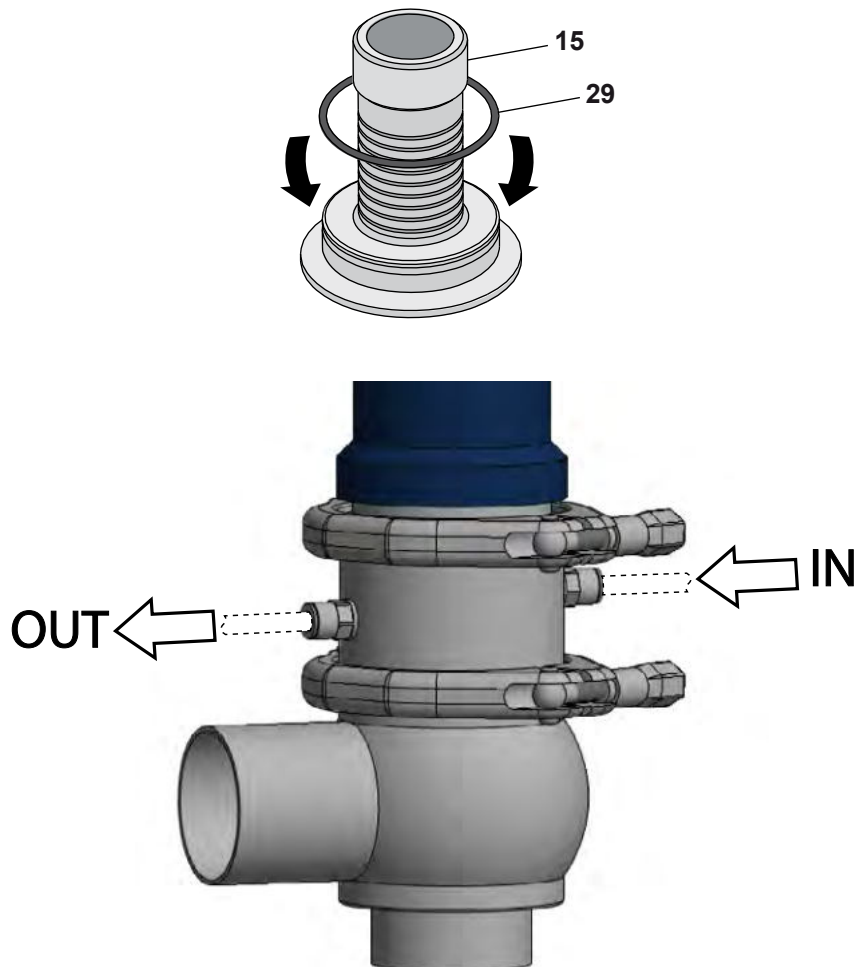
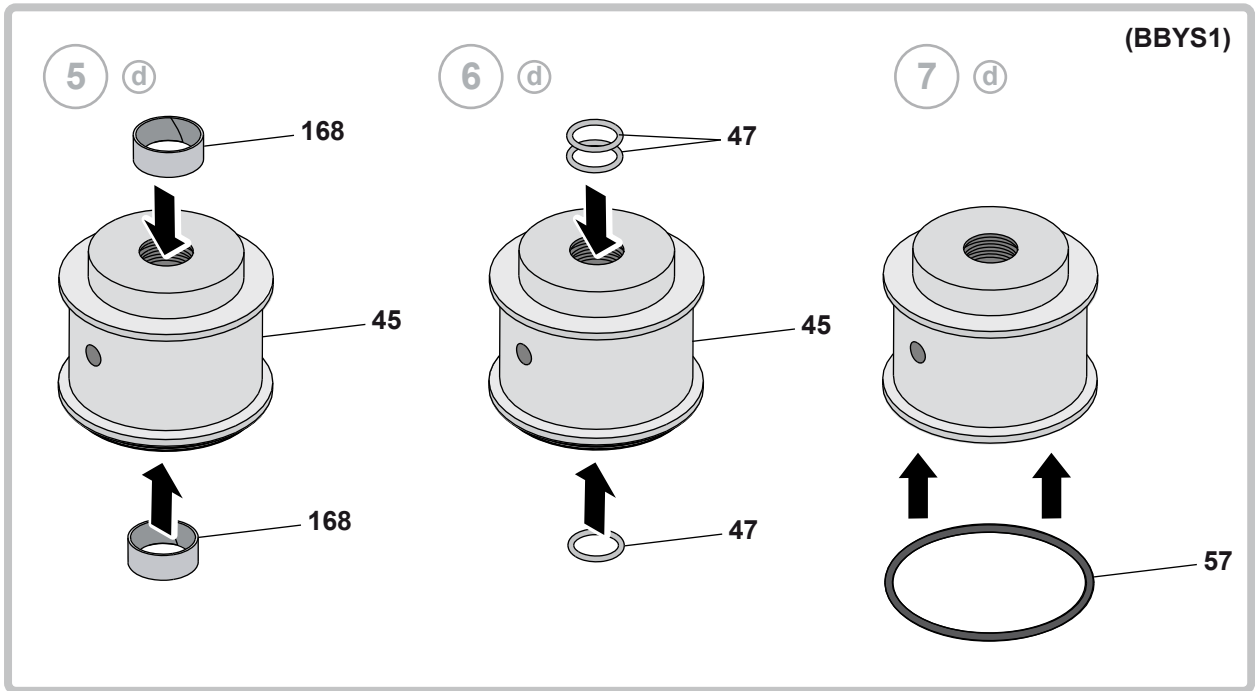

BBZS1

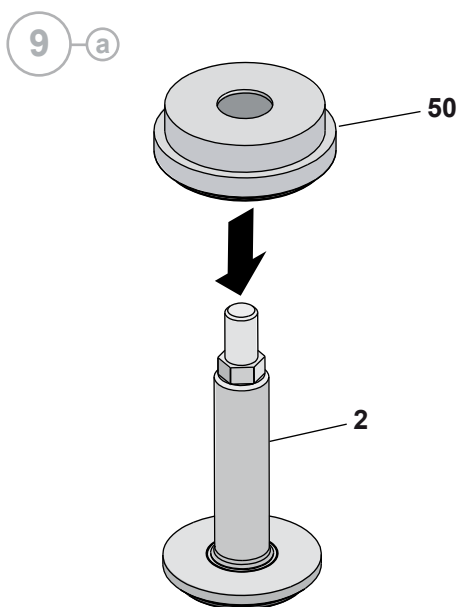

BBYS1

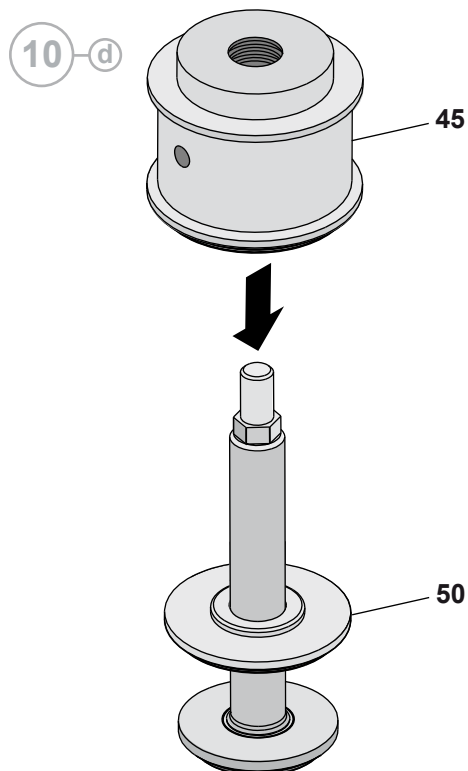
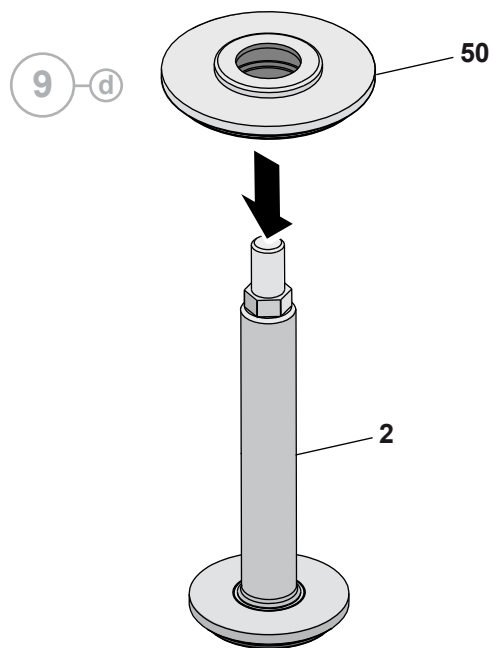

BBZS1

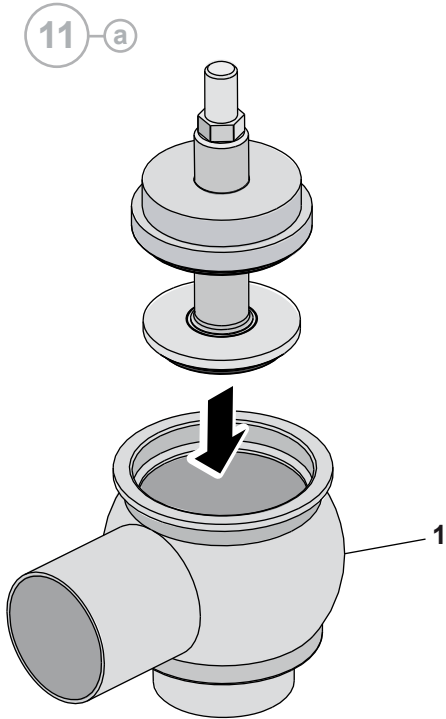

11-a

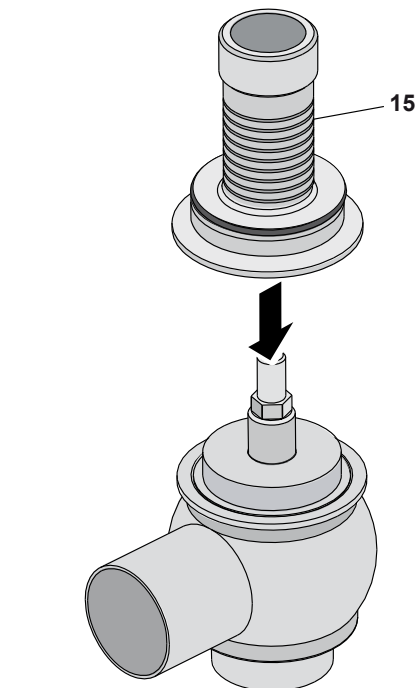

12-a

BBYS1

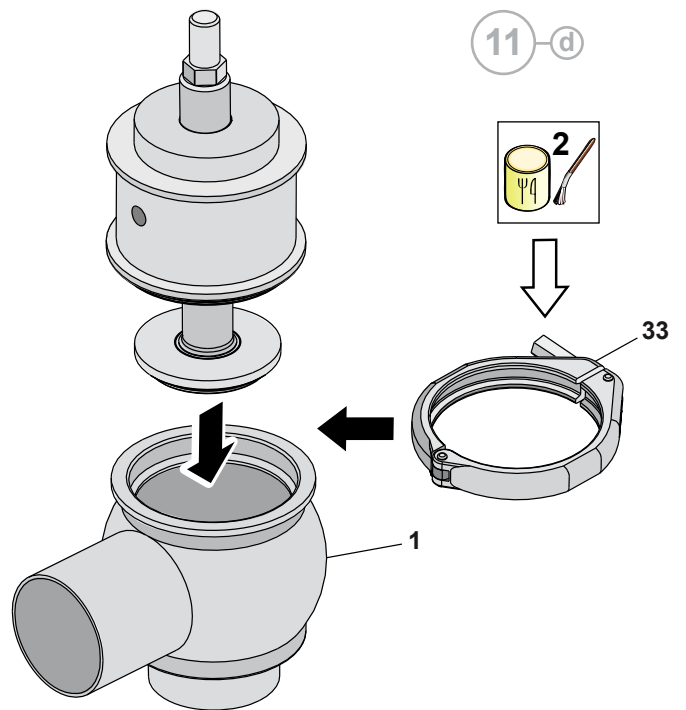

11-d

12-d

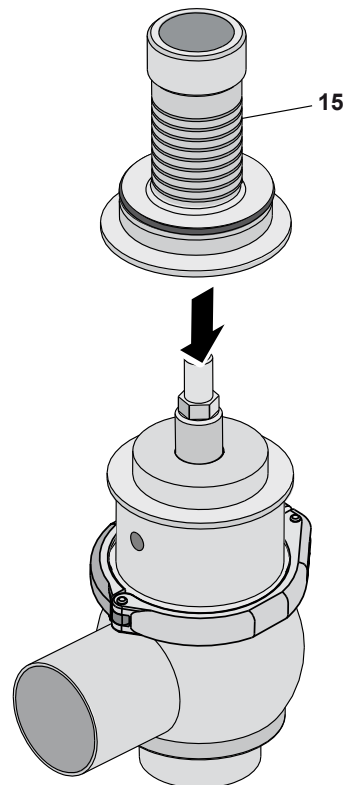

13

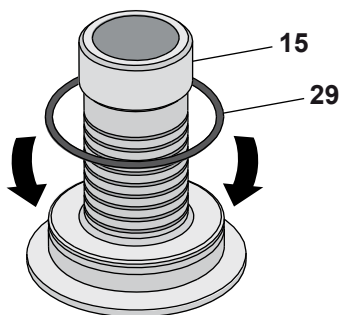

14 a

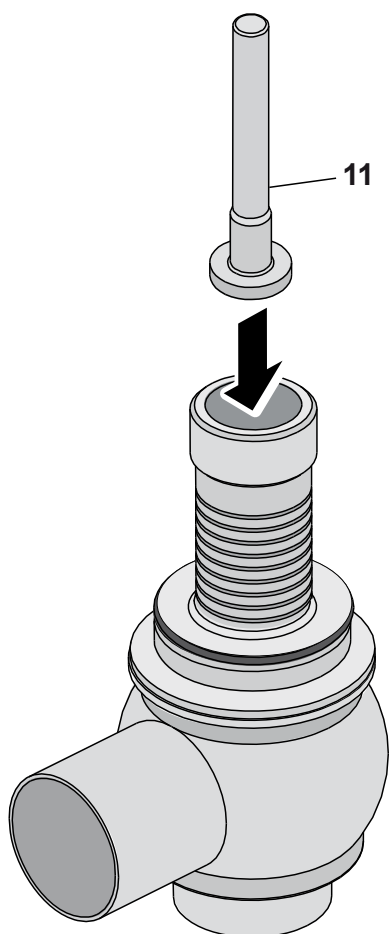

14 d

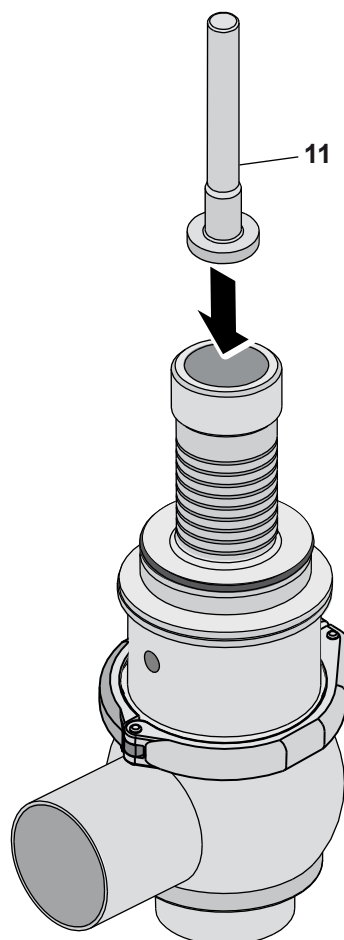

15

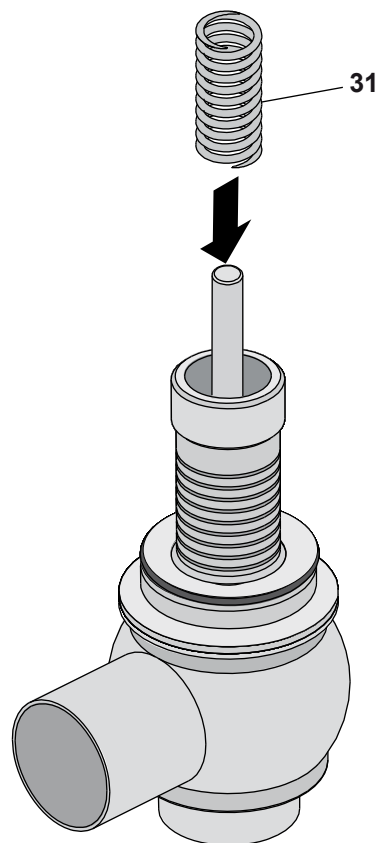

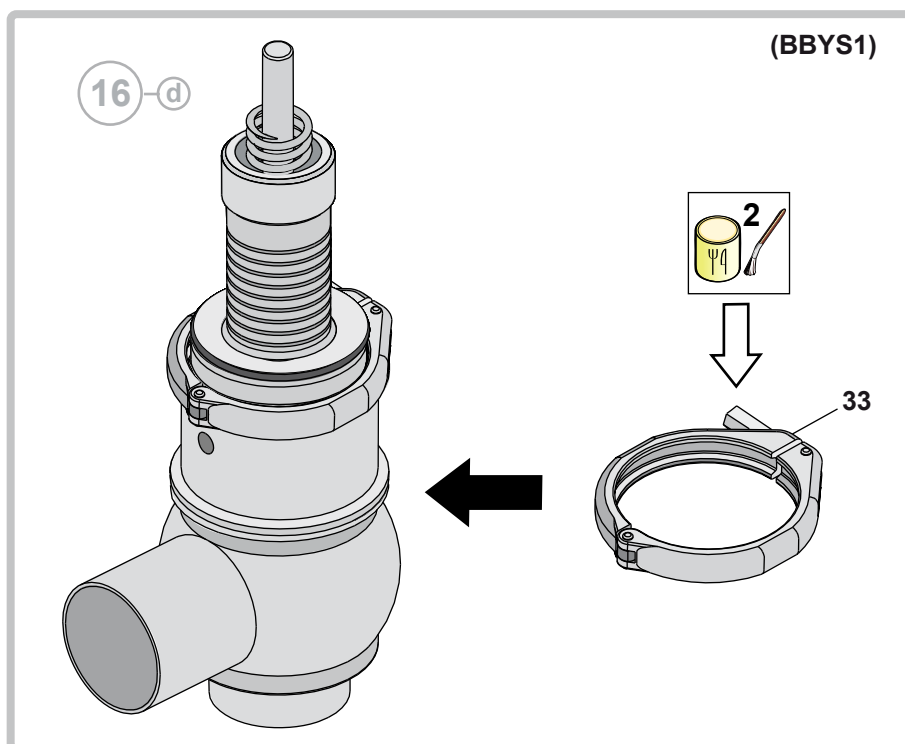
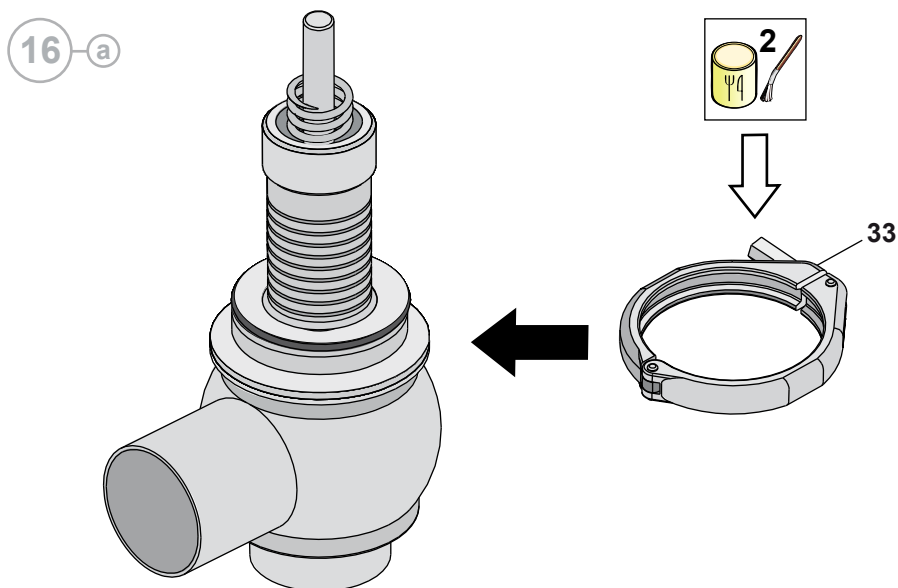

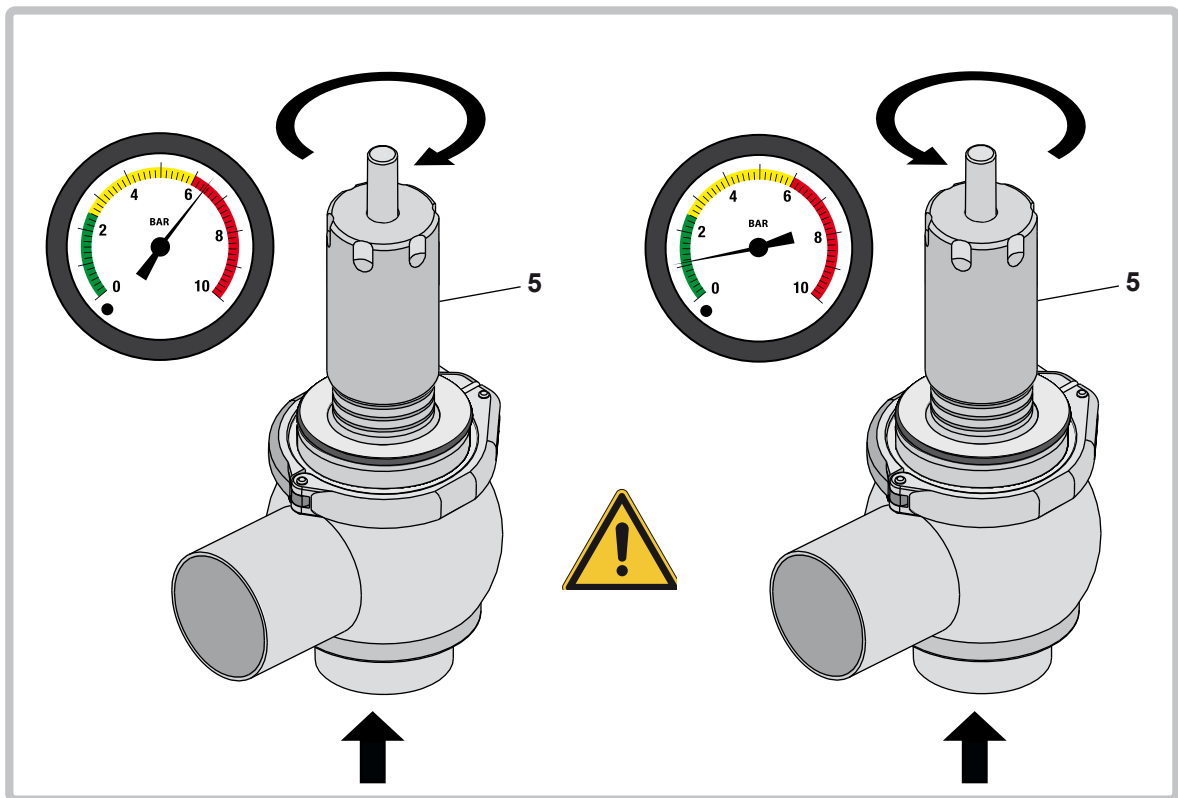
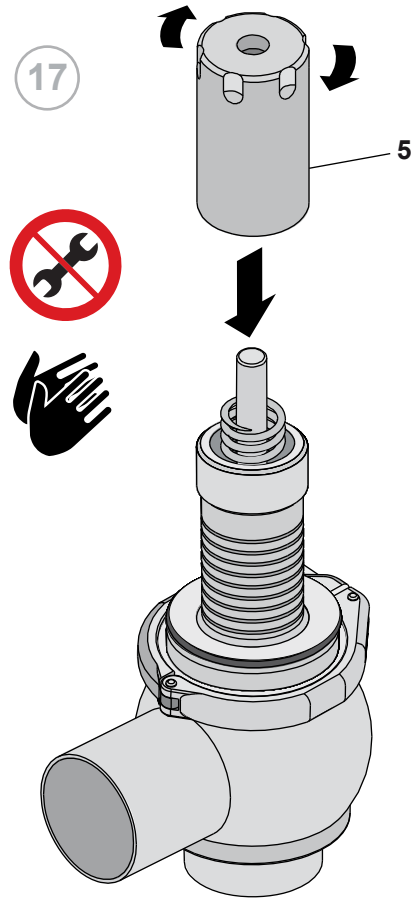
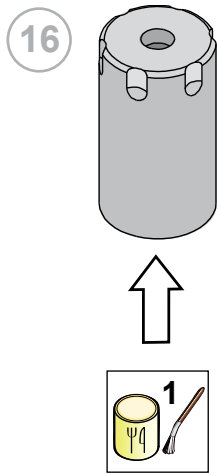

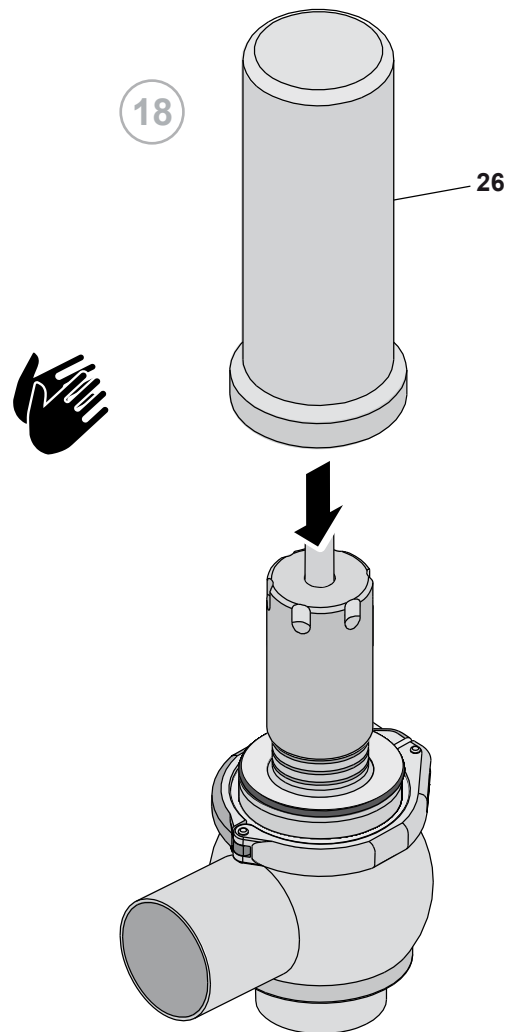

B Assembly of the BBWS11

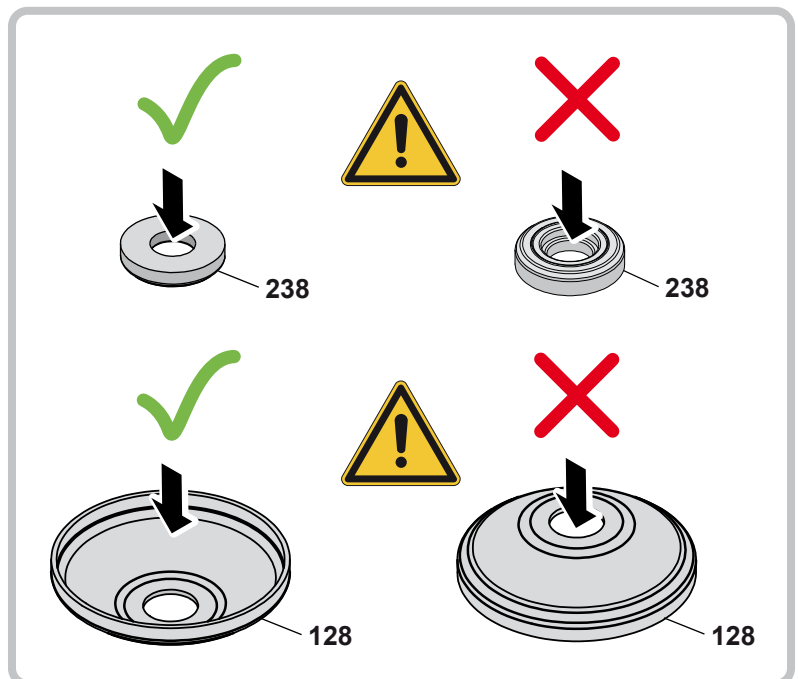
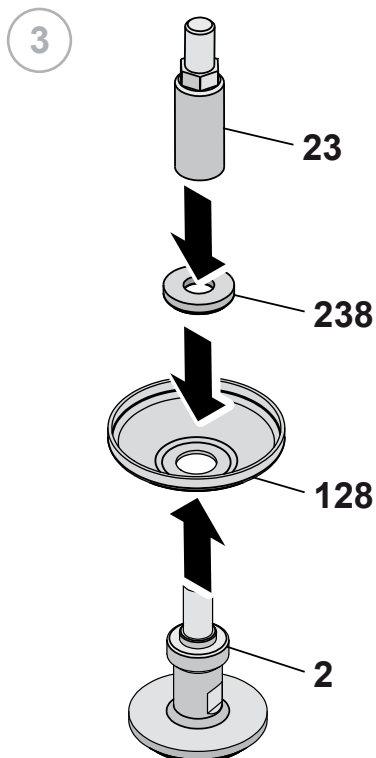
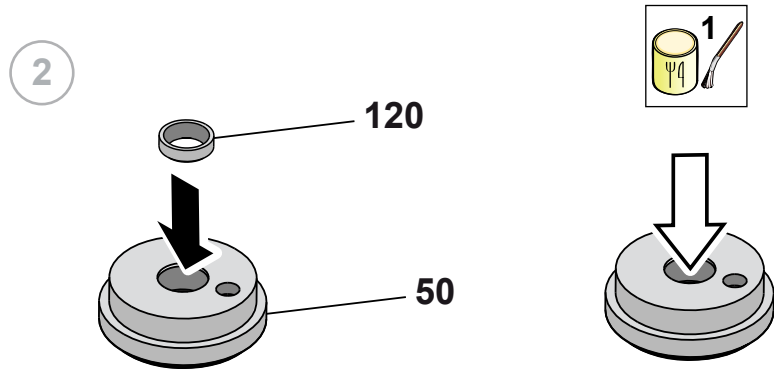
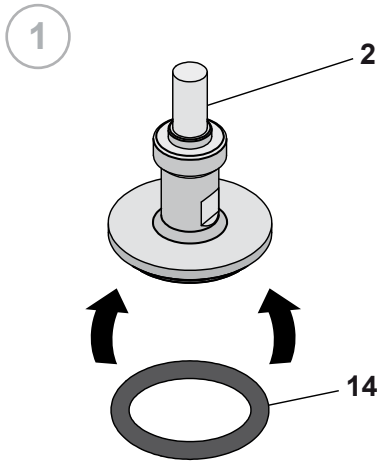

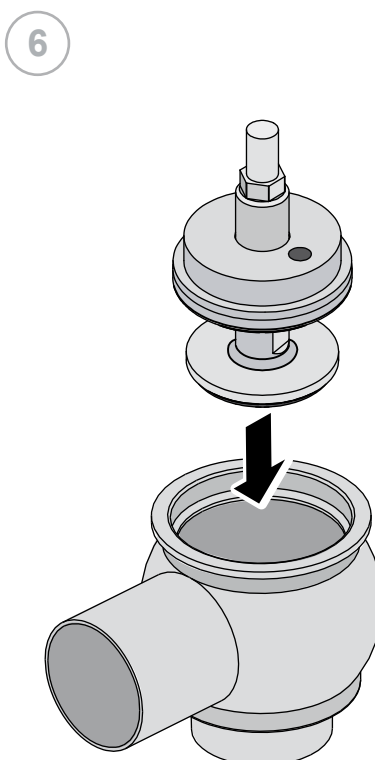
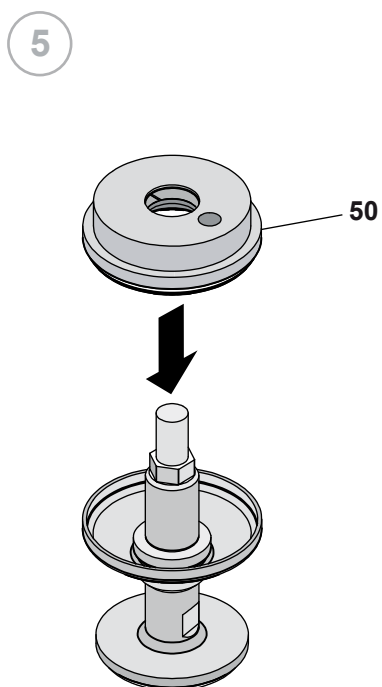
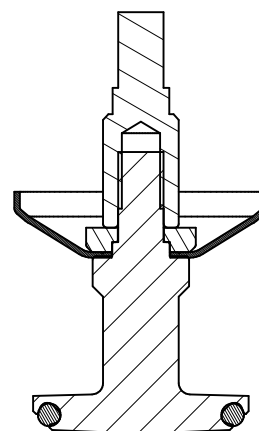
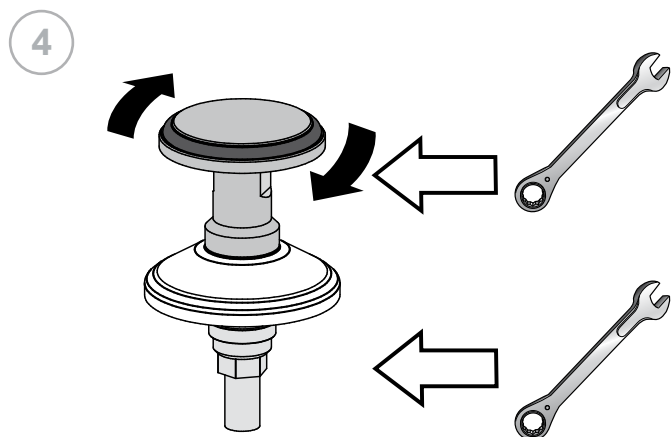

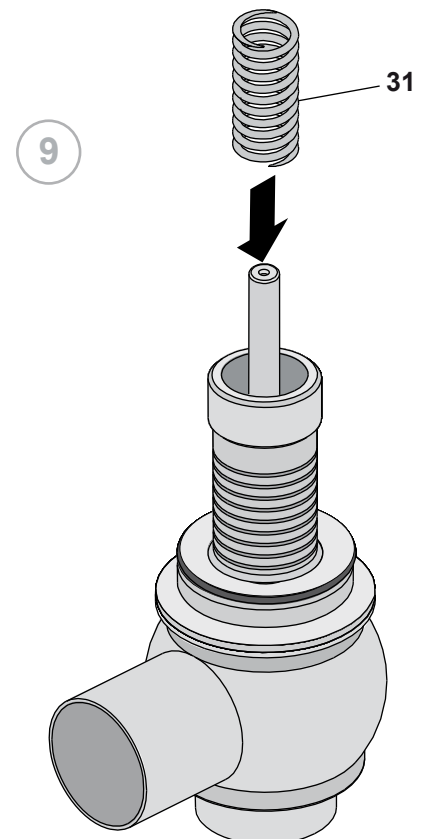
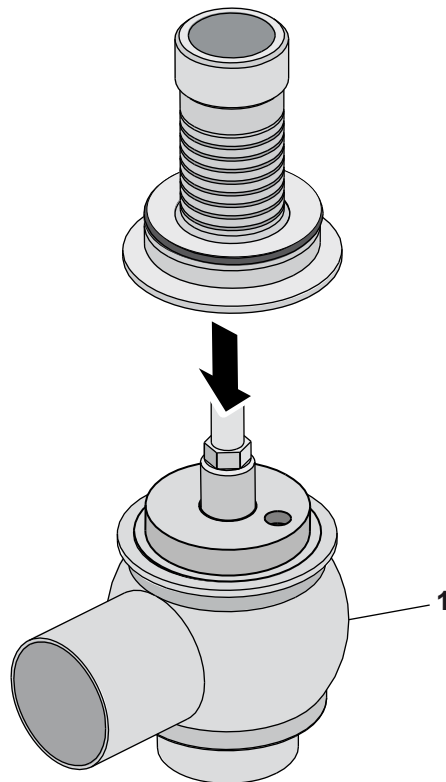
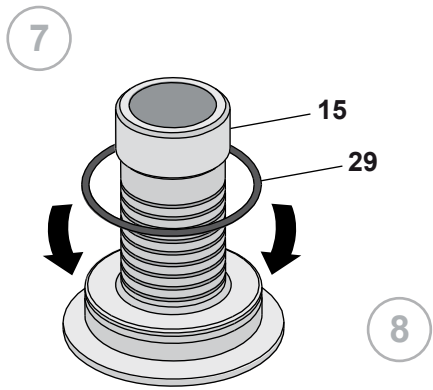

10

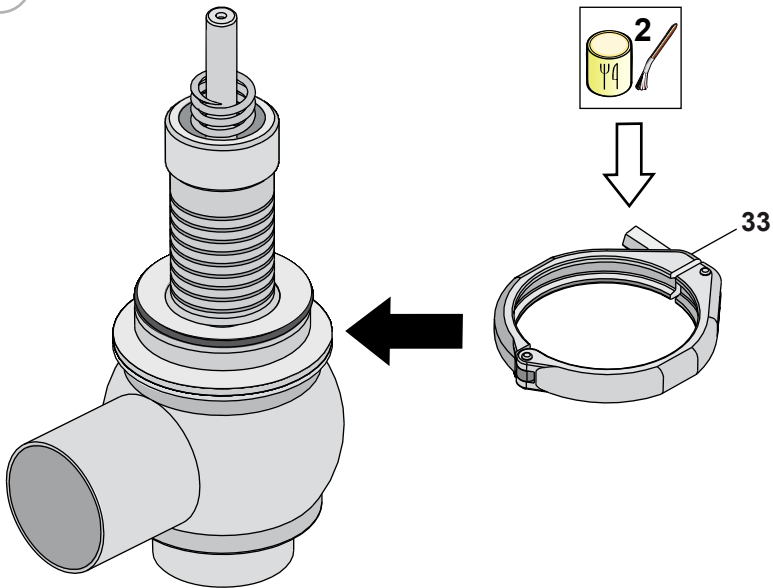

11

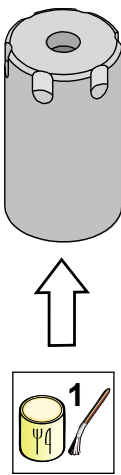

12

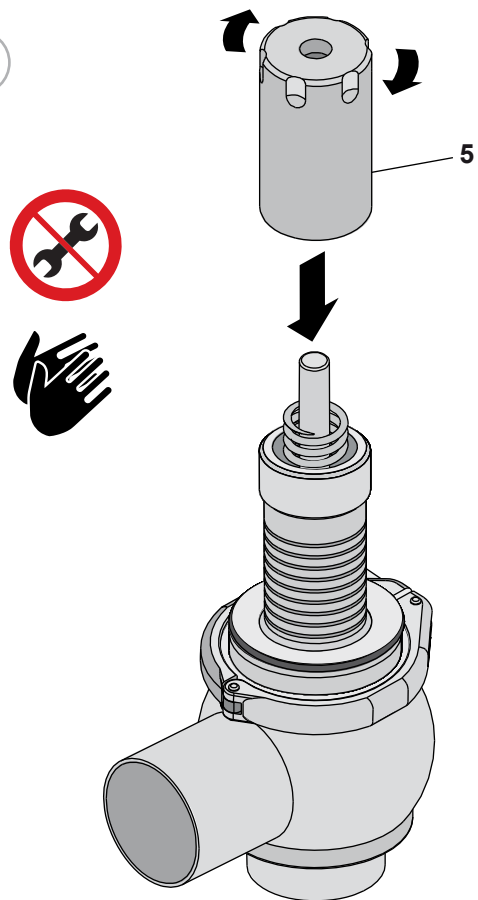

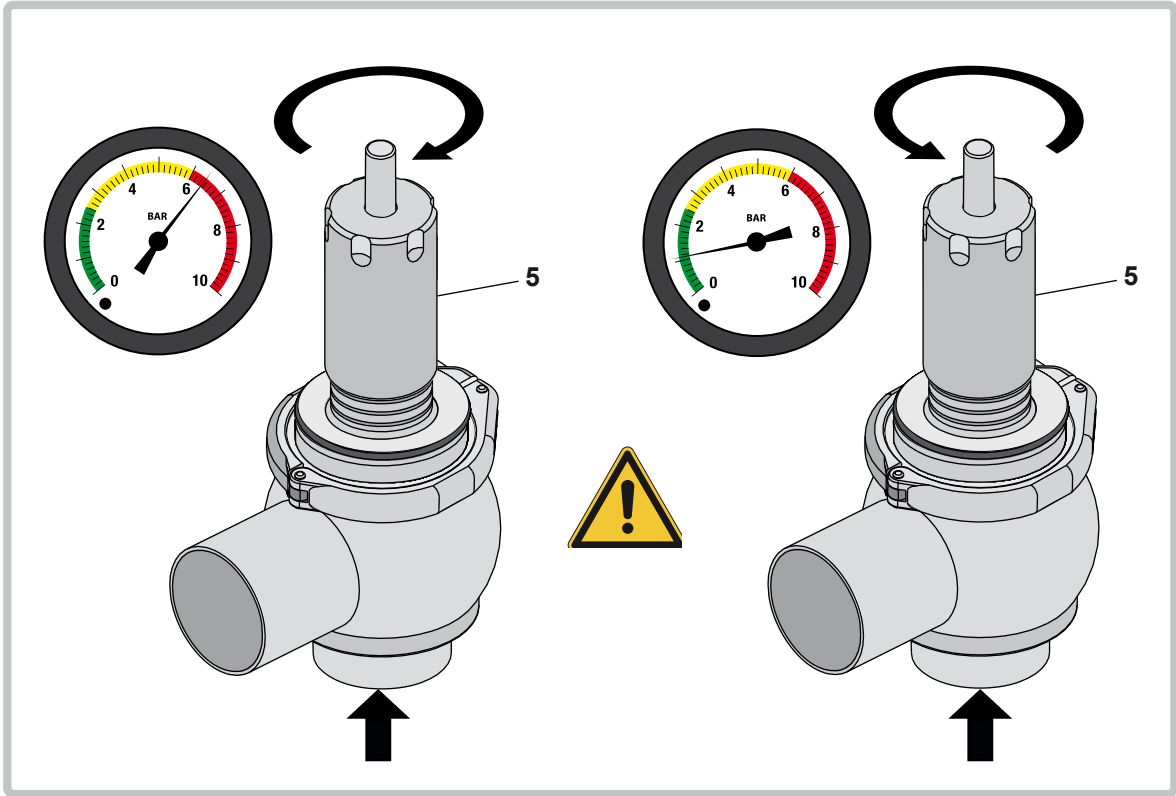

13

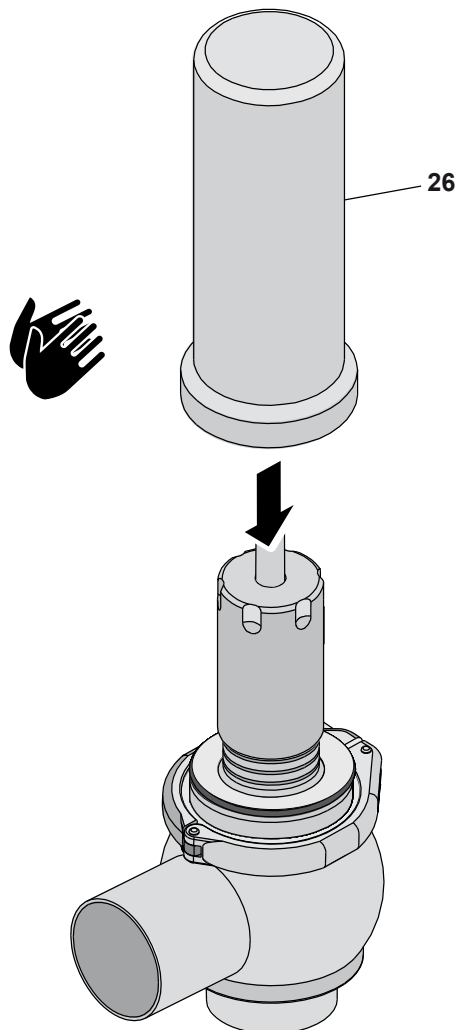

11 Annexes



GB - EC Declaration of conformity - without electric components - A5-P-PRG-GB

EC DECLARATION OF CONFORMITY OF THE MACHINERY

(EC) 2006/42, Annex. II, p. 1 A

BARDIANI VALVOLE S.p.A.

Via G. di Vittorio 50/52 – 43045 Fornovo di Taro (Pr) – Italia

Declares

under its own responsibility that the machine:

Type:	PNEUMATIC VALVES
Model:	#####
Serial number:	#####
Function:	Fluid handling
Year of construction:	2018
Reference	#####

complies with all relevant provisions of the following EC directives:

(EC) 2006/42 MACHINERY

and the following harmonized standards, rules and / or technical specifications applied:

EN ISO 12100:2010

REGULATION (EC) 1935/2004 and subsequent amendments and additions with regard to steel and elastomers in contact with the product

Fornovo di Taro

20/09/2018

Legal Representative

A5-P-PRG-GB Ed. 1. Rev. 0

BARDIANI VALVOLE S.p.A.
Via G. di Vittorio 50/52
43045 Fornovo di Taro (Pr)

12 2D diagram BBZS1

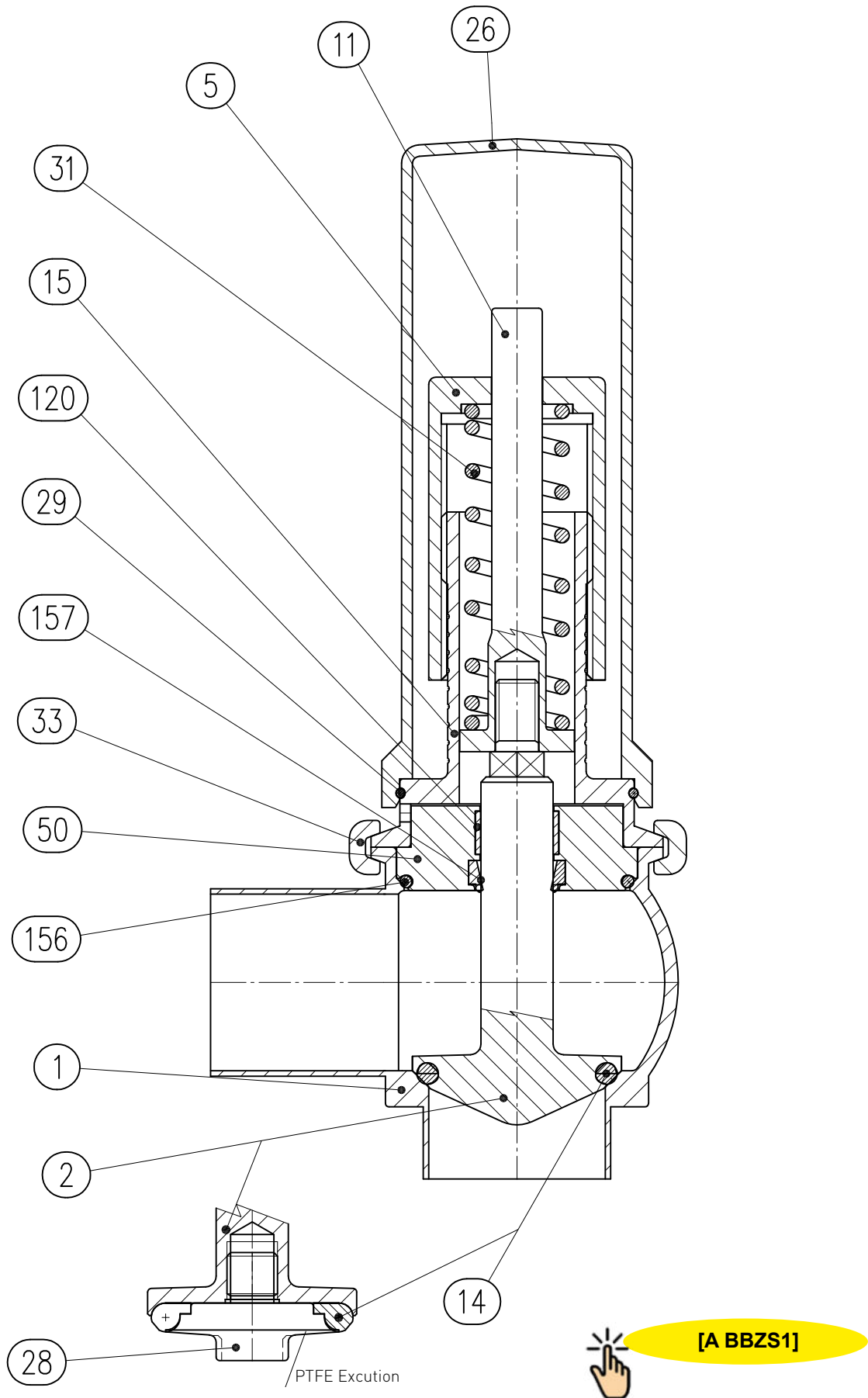

13 2D diagram BBYS1

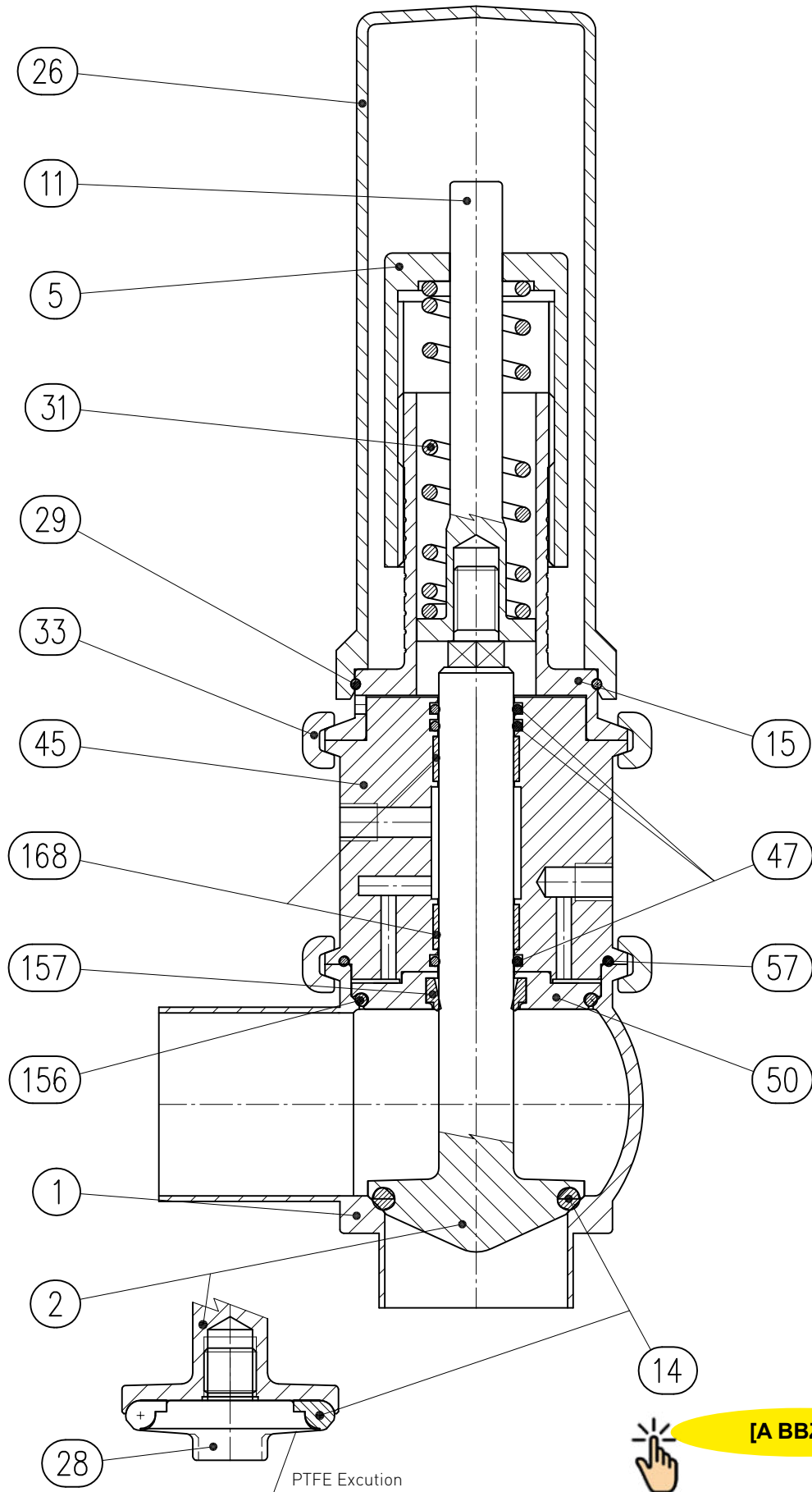

14 2D diagram BBWS11

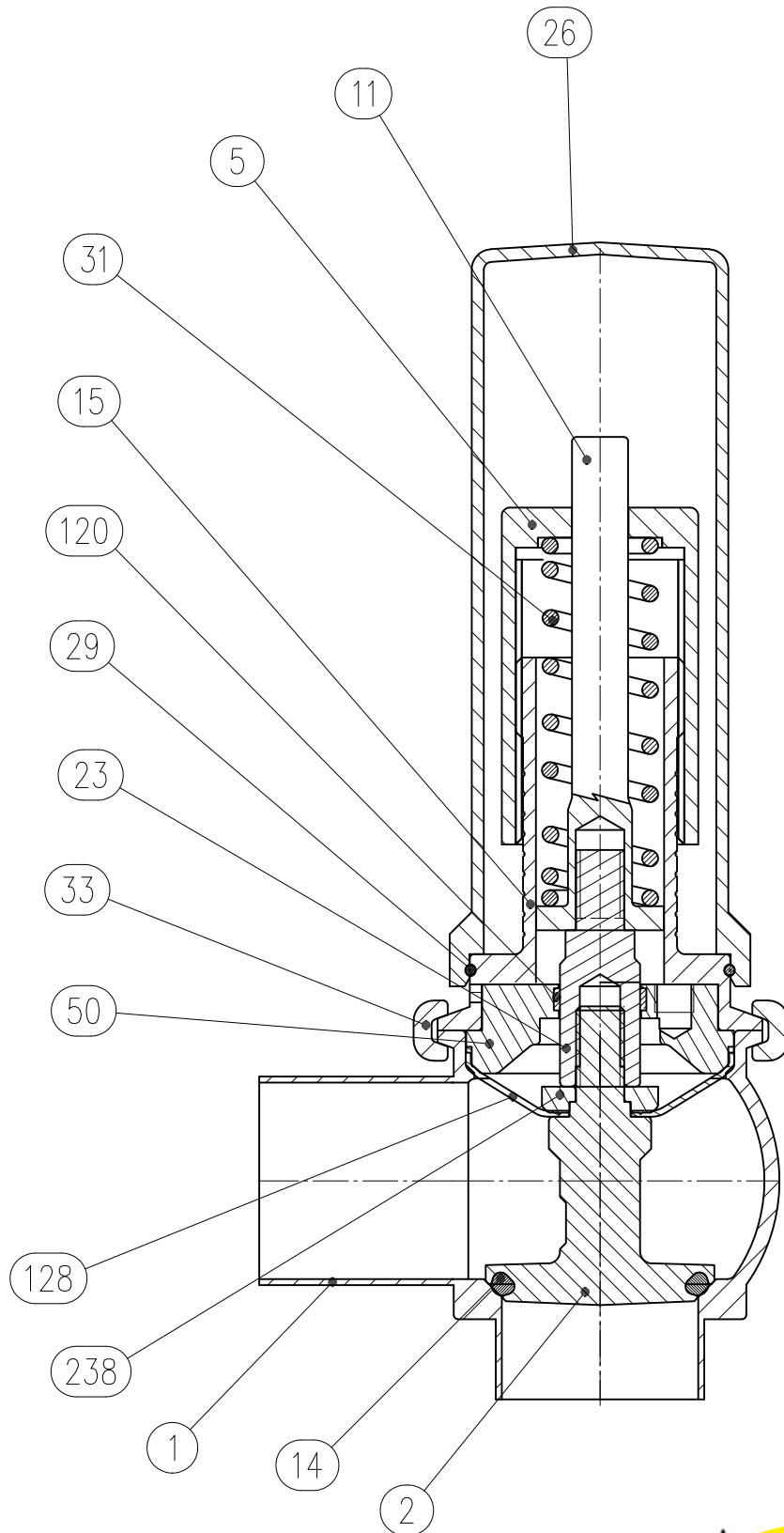

[B S BBWS11]

15 Warranty

1. VALIDITY

Bardiani Valvole's Products are manufactured in compliance with the technical specifications laid out in their "Instruction, Use and Maintenance Manual" and are fully compliant with the directives specifically mentioned in these manuals.

Bardiani Valvole S.p.A. guarantees its own Products against any design and/or construction and/or material defects and/or faults for a period of 12 (twelve) months from the date of delivery.

Notification of any Product defects and/or faults must be sent in writing to Bardiani Valvole S.p.A. within 8 (eight) days from their detection, providing adequate documentation of the defect/fault encountered as evidence.

Services provided in the warranty period shall not result in an extension of the warranty beyond the stipulated 12 (twelve)-month period, as this warranty validity period is to be considered mandatory.

2. CONTENTS OF THE WARRANTY

Notwithstanding and without prejudice to the rights of the Buyer, which may be acknowledged by applicable law, this warranty is to be intended as limited, at the discretion of Bardiani Valvole S.p.A., to the repair and/or replacement of the Product and/or part of the Product and/or its components which is/are found to be defective due to design and/or manufacturing and/or material faults.

- In the event of repair and/or replacement of the Product and/or any one of its parts and/or components, any returned item/s shall become the property of Bardiani Valvole S.p.A. and the relative shipping costs shall be charged to Bardiani Valvole S.p.A.
- Bardiani Valvole S.p.A., shall be under no obligation to compensate for any immaterial and/or indirect damages and shall in no way be held liable for consequential damages and/or losses, such as (by way of example only), damages due to loss of business, contracts, opportunities, time, production, profits, goodwill, image etc.
- No retailer or distributor or dealer or agent or representative or employee or person appointed by Bardiani Valvole S.p.A. is authorized to make any amendments and/or integrations and/or extensions to this warranty.

3. WARRANTY EXCLUSIONS

Elastomers and electrical components are expressly excluded from this warranty.

This warranty does not cover design faults emerging whenever a Product is manufactured by Bardiani Valvole S.p.A. based on designs and/or technical specifications provided by the Buyer.

Moreover this warranty excludes the following:

- faults and/or defects resulting from incorrect and/or unsuitable and/or inadequate transportation of the Product;
- faults and/or defects resulting from failure to comply with the indications laid out in the "Instruction, Use and Maintenance Manual" with regards to installation of the Product or in any event caused by incorrect and/or unsuitable and/or improper installation;
- faults and/or defects resulting from failure to comply with indications laid out in the "Instruction, Use and Maintenance Manual" with regards to use and/or maintenance operations and/or storage of the Product or in any event caused by incorrect and/or unsuitable and/or improper use and/or maintenance operations and/or storage;
- faults and/or defects due to normal wear and tear of the Product and/or its parts and/or its components;
- faults and/or defects in the Product and/or its parts and/or its components for work and/or repairs being carried out by unskilled staff or staff that has not been authorised by Bardiani Valvole S.p.A.;
- faults and/or defects in the Product and/or its parts and/or its components due to it/them being dropped and/or banged and/or dented and/or misused and/or tampering and/or breakage and/or accidents or in any event due to negligence and/or carelessness and/or neglect by the Buyer and in general for any causes not attributable to design and/or manufacturing and/or material defects;
- faults and/or defects in the Product and/or its parts and/or its components caused by other events beyond the control of Bardiani Valvole S.p.A., such as force majeure or unforeseeable circumstances.

16 Recommendations

- 1.** 1.Consultation of the "Instruction, Use and Maintenance Manual" is mandatory prior to the installation, use and maintenance of the products of all Products. All the information, indications, specifications, technical details provided herein are based on test data which the Manufacturer Bardiani Valvole S.p.A. holds to be reliable nevertheless the above is not deemed to be assumed as fully exhaustive inasmuch as not every possible use has been envisaged.
- 2.** 2.All the illustrations and drawings provided are to be intended as indicative and therefore not binding, the illustrations being for presentation purposes only.
- 3.** 3.It is the Buyer's duty to assess the suitability of the products for the use he intends to make of the same prior to placing the order as he/she will take the risks and accept liability in case of incorrect choice and use of the Products.
- 4.** 4.The Manufacturer strongly recommends the Buyer to contact their sales team and request any information that might be needed in relation to the specifications and uses of the Products.
- 5.** 5.The information provided in this manual refers to the standard products manufactured by Bardiani Valvole S.p.A. and therefore cannot be assumed to apply to customized products as well.
- 6.** 6.Bardiani Valvole S.p.A. reserves the right to amend and/or integrate and/or update the data and/or information and/or technical details relative to Products at any time and without prior notice. Please visit the website www.bardiani.com, where the latest updated of the "Instruction, Use and Maintenance Manual" can be found".
- 7.** 7.The content and validity of the warranty covering the Products of Bardiani Valvole S.p.A are dealt with in the relevant section in the "Instruction, Use and Maintenance Manual" which constitutes an integral part of the Products themselves.
- 8.** 8.Bardiani Valvole S.p.A., shall not in anyway be held liable for immaterial, indirect and consequential damages, such as (by way of example only), damages or loss of business, contracts, opportunities, time, production, profits, goodwill, image etc..



NOTES

Bardiani Valvole S.p.A.
via G. di Vittorio, 50/52 - 43045 Fornovo di Taro (PR) - Italy
tel. +39 0525 400044 - fax +39 0525 3408
bardiani@bardiani.com - www.bardiani.com