

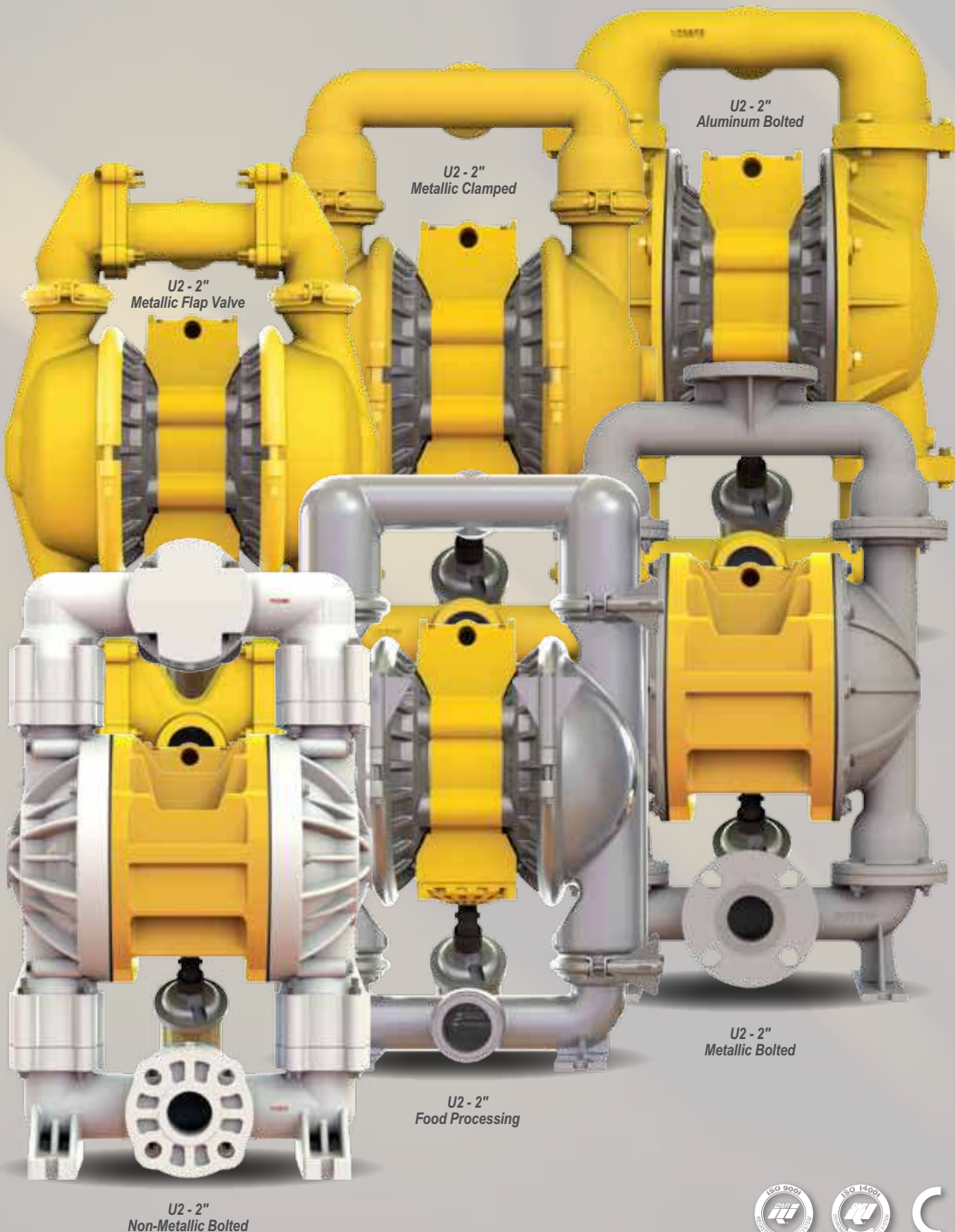

VERSA-MATIC®

Delivering Quality, Interchangeable Pumping Solutions

- Metallic Pumps
- Non-Metallic Pumps
- Special Pumps
- Upgrade Kits
- Parts & Accessories



FEATURES & BENEFITS



Air Valve Efficiency
No costly air leakage (blow by) with expanding u-cup seals, lapped ceramic valve components and inset track gaskets providing a superior seal.



Ease of Maintenance
No special tools or training needed with an easily accessible air valve, air side wear components and parts that are available in economical kits or as individual components.



Extended In-Service Life
Improve your total cost of ownership with self lubricating seals, precision low friction bearing surfaces and robust shafts to ensure durability.



Superior Flow Rates
Volumetric efficiency is created with more fluid per stroke by instantly exhausting the air chamber pressure from behind the diaphragms directly to the atmosphere.



Pilot Shaft
On/Off Reliability: Consistent pump start up is ensured by positive modulating air pressure directed from the pilot shaft to the valve spool.

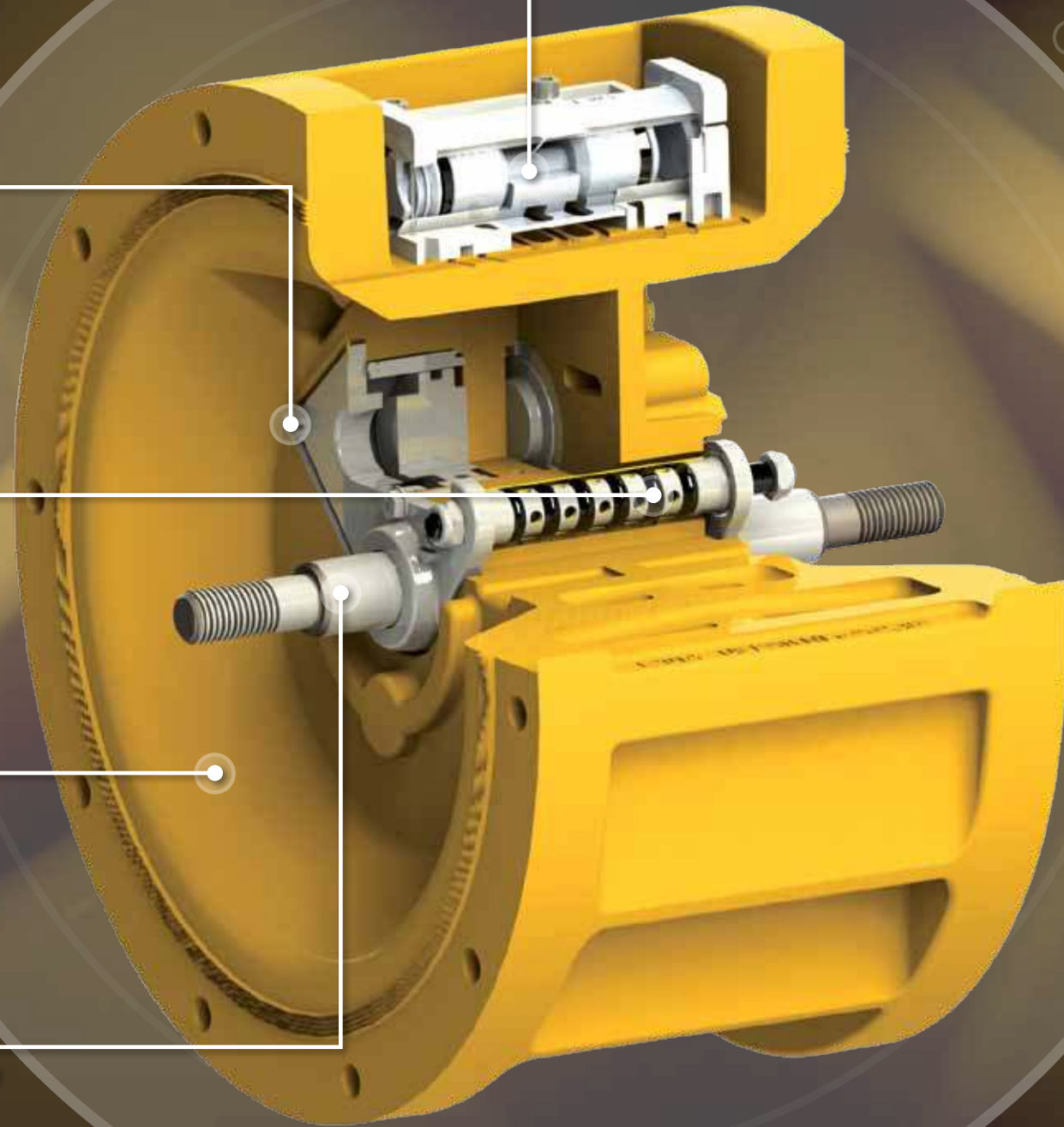

How the U2 Works

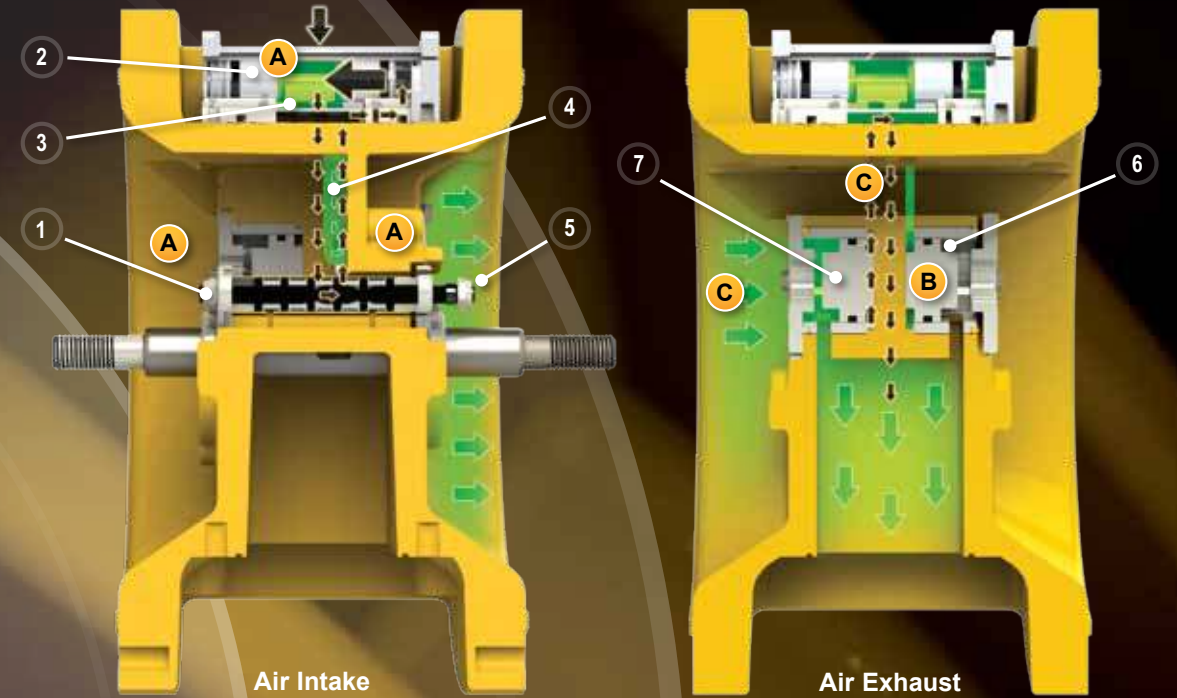

- A** The pilot shaft (1) is mechanically shifted by contact from the inner diaphragm plate allowing air pressure to be directed behind one end of the valve spool (2), shifting it and holding it in place.
- B** The valve spool actuates the ceramic air diverter (3), opening the right hand air chamber filling port (4) and directing compressed air into the air chamber (5) and behind the exhaust valve (6) — keeping it closed so no air can escape.
- C** Simultaneously, the pressure is relieved from the opposing exhaust valve (7) allowing it to open, and instantly exhausts the air chamber pressure to atmosphere. When the pump completes its stroke, the pilot shaft (1) is again mechanically shifted causing the process to repeat on the opposite side.

Superior Chemical Resistance and Material Options

The Ultra-Matic incorporates many superior materials to deliver excellent chemical resistance, reduce repair cost and extend service life.



1-piece centers are available with:

- Stainless Steel Shafts
- Ceramic Shoe and Diverter
- Polypropylene Center Block
- PVDF Valve Body



3-piece centers are available with:

- Stainless steel
- Aluminum
- PTFE coated aluminum
- Nickel plated aluminum

Ultra-Matic® 2" Bolted Plastic Pumps

Side Porting Standard, Center Porting Optional

Specifications

Flow Rate	adjustable to 0-192 gpm (0-727 lpm)
Port Size	Inlet and Outlet 2" ANSI/DIN #50 Flange
Air Inlet	0.50" NPTF
Air Exhaust	0.75" NPTF
Suction Lift* (dry)	
Rubber	20' (6.10 m)
PTFE	10' (3.05 m)
Max Particle Size	
Diameter	0.25" (6 mm)
Shipping Weight	
Poly, End Port	67 lbs (30 kg)
Poly, Center Port	72 lbs (33 kg)
PVDF, End Port	93 lbs (42 kg)
PVDF, Center Port	98 lbs (44 kg)

Performance

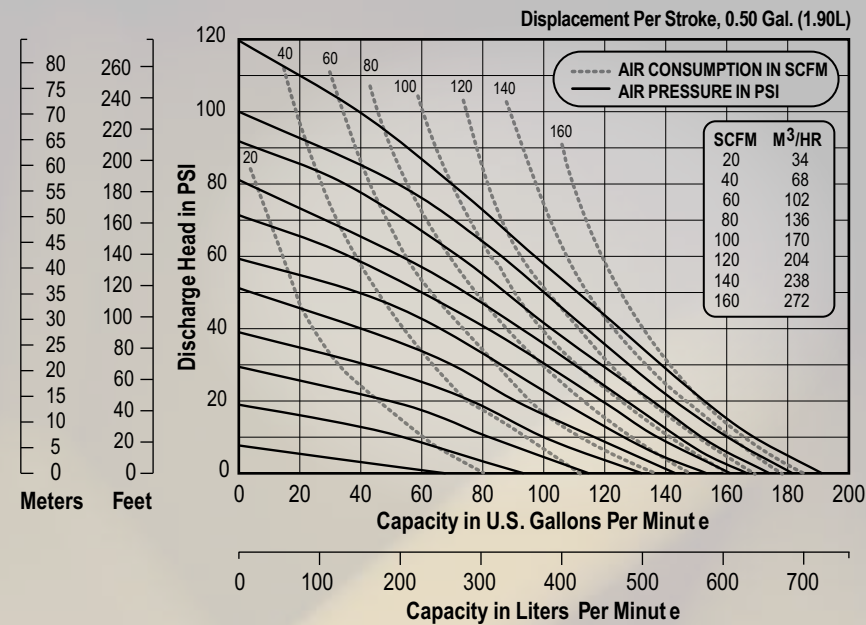

* For U2 pumps fitted with PTFE diaphragms, reduce water discharge figures by 20%. Suction lift is reduced to 10' (3.05 m) dry and 20' (6.10 m) wet.

Dimensions

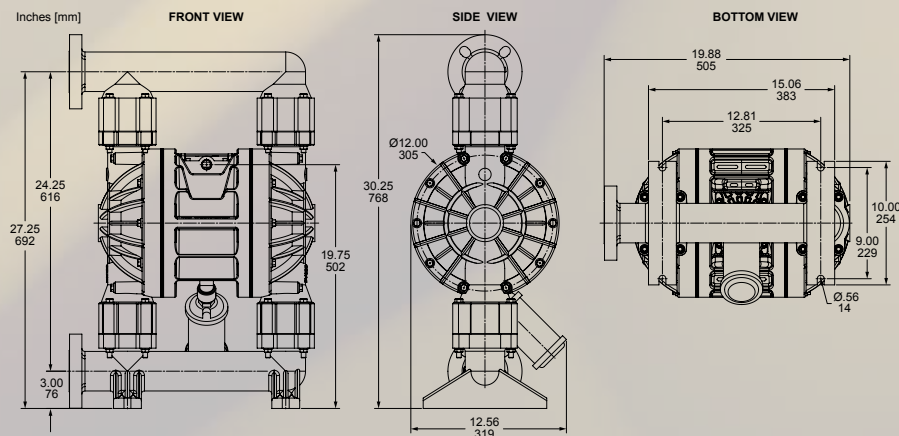

One-piece molded non-metallic center section



Available with side or center-mounted ports

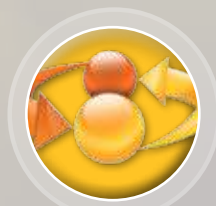

Dimensionally interchangeable with Wilden® Original™ Series nonmetallic units

Ultra-Matic® 2" Bolted Metallic Pumps

Vertical Porting Standard, Horizontal Porting Optional

U2

Performance

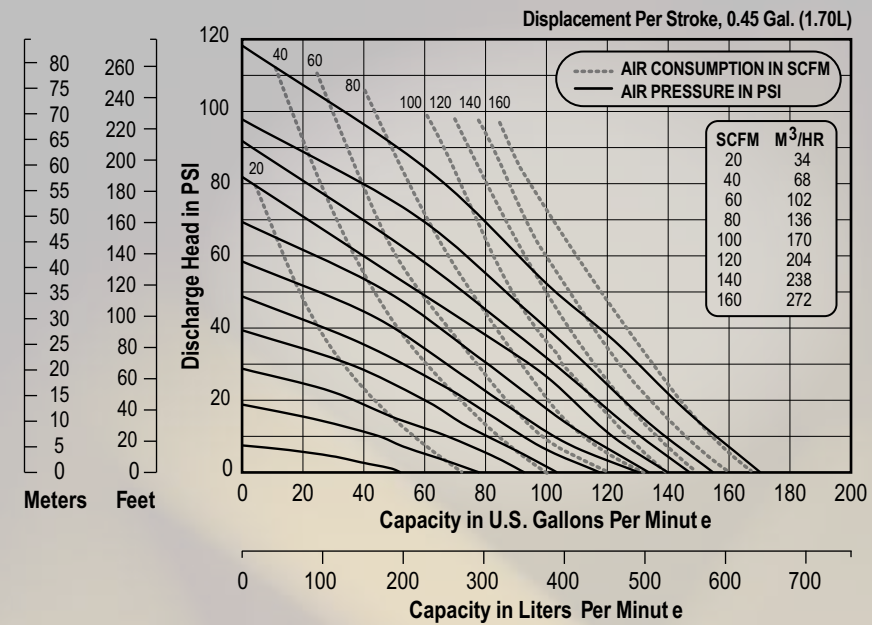

* For U2 pumps fitted with PTFE diaphragms, reduce water discharge figures by 20%. Suction lift is reduced to 10' (3.05 m) dry and 20' (6.10 m) wet.

Dimensions

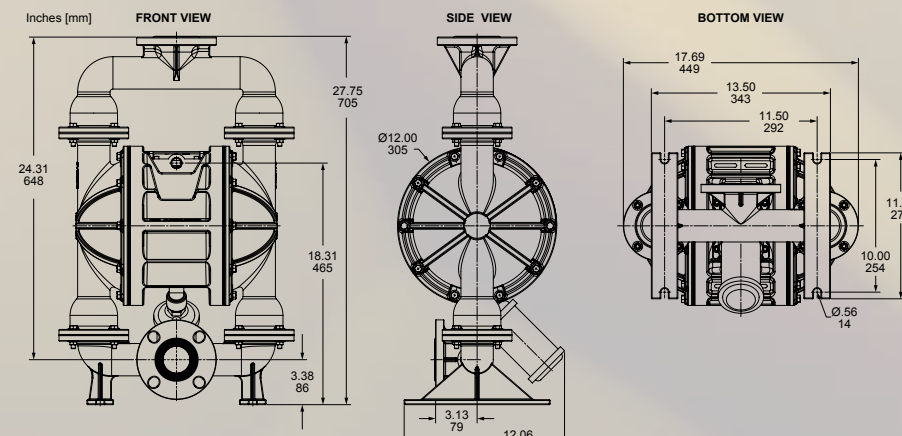

One-piece molded non-metallic center section



Includes both ANSI and DIN flange connections



Available with vertical or horizontal discharge



Specifications

Flow Rate	adjustable to	0-182 gpm (0-689 lpm)
Port Size	Inlet and Outlet	2" Female NPT (BSP)
Air Inlet		0.50" Female NPT
Air Exhaust		0.75" Female NPT
Suction Lift* (dry)		
Rubber	20'	(6.10 m)
PTFE	10'	(3.05 m)
Max Particle Size		
Diameter		0.25" (6 mm)
Shipping Weight		
Aluminum		69 lbs (31 kg)
Cast Iron		114 lbs (52 kg)
Hastelloy		124 lbs (56 kg)
Stainless Steel		114 lbs (52 kg)

Performance

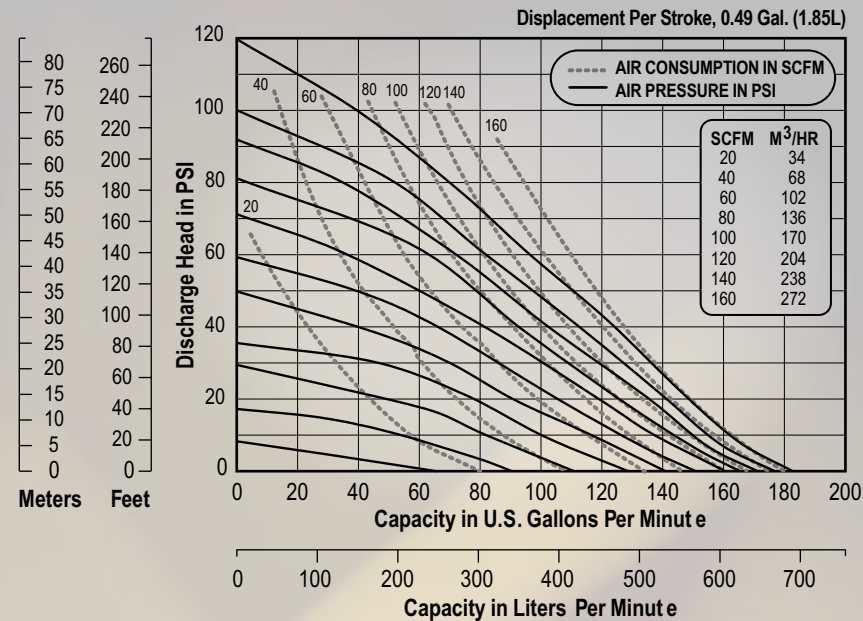

* For U2 pumps fitted with PTFE diaphragms, reduce water discharge figures by 20%.
Suction lift is reduced to 10' (3.05 m) dry and 20' (6.10 m) wet.

Dimensions

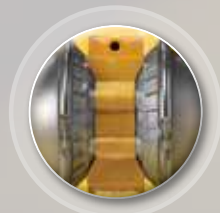
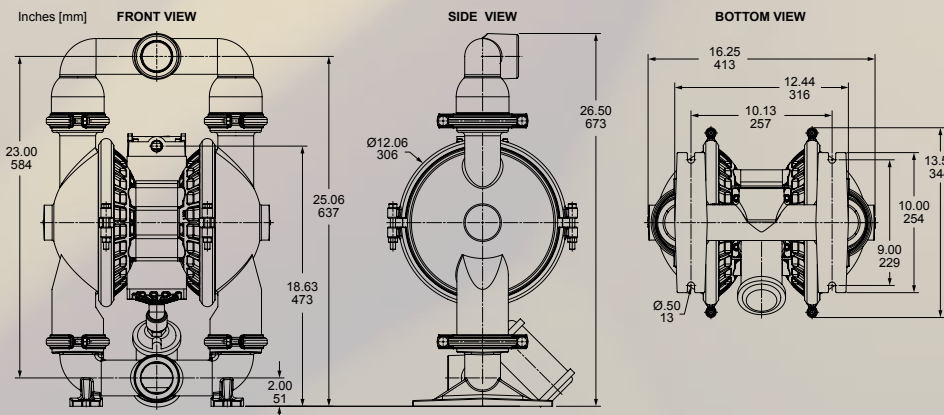

Three-piece center section with **non-metallic center** and metallic air chambers



Clamp design provides quick teardown for repairs



Pumps and center sections are **interchangeable** with Wilden® 2" Original™ Series clamp style pumps

Performance

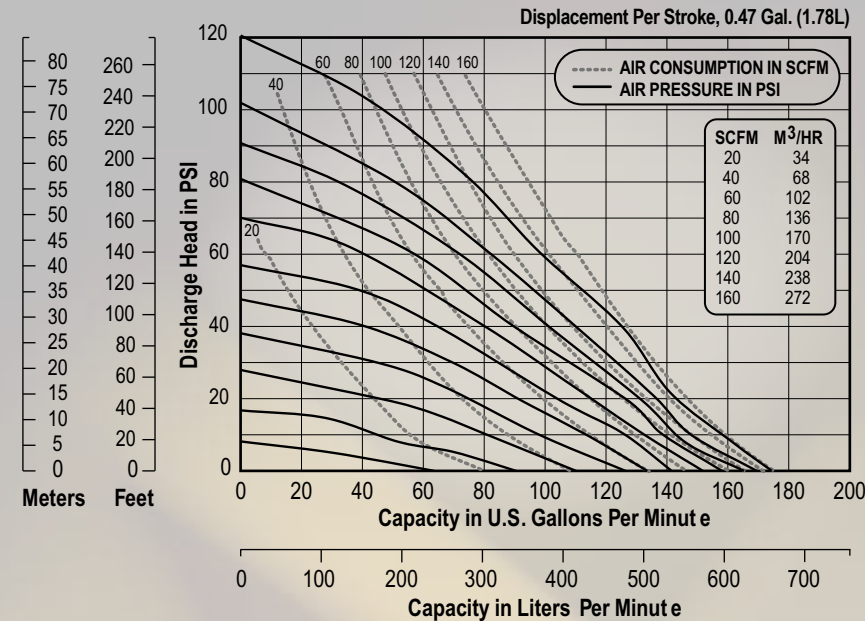

* For U2 pumps fitted with PTFE diaphragms, reduce water discharge figures by 20%.
Suction lift is reduced to 10' (3.05 m) dry and 20' (6.10 m) wet.

Dimensions

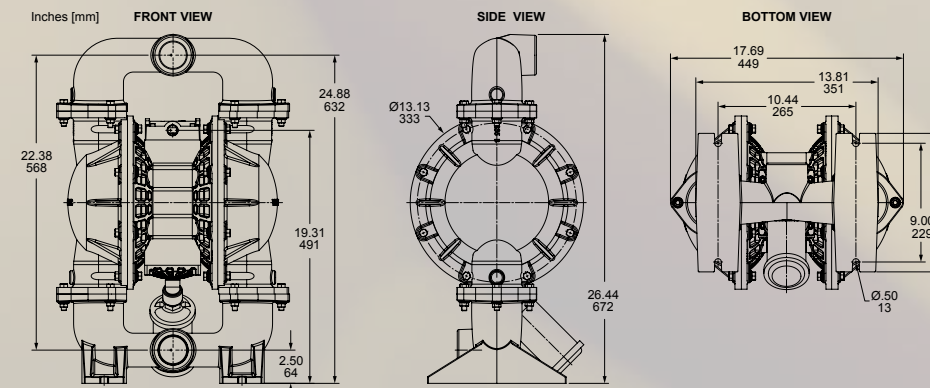

Leak-free bolted design for a greater positive seal



Cast-in boss allows for installation of **drain plugs**



The most solid feet in the industry for **improved durability**

Specifications

Flow Rate	adjustable to	0-175 gpm (0-662 lpm)
Port Size	Inlet and Outlet	2" Female NPT (BSP)
Air Inlet		0.50" NPTF
Air Exhaust		0.75" NPTF
Suction Lift* (dry)		
Rubber	20'	(6.10 m)
PTFE	10'	(3.05 m)
Max Particle Size		
Diameter		0.43" (11 mm)
Shipping Weight		
Aluminum		75 lbs (34 kg)



Specifications

Flow Rate adjustable to	0-182 gpm (0-689 lpm)
Port Size Inlet and Outlet	2.5" Tri-Clamp
Air Inlet	0.50" Female NPT
Air Exhaust	0.75" Female NPT
Suction Lift* (dry)	
Rubber	20' (6.10 m)
Teflon®	10' (3.05 m)
Max Particle Size	
Diameter	0.44" (11 mm)
Shipping Weight	
Stainless Steel	117 lbs (53 kg)

Performance

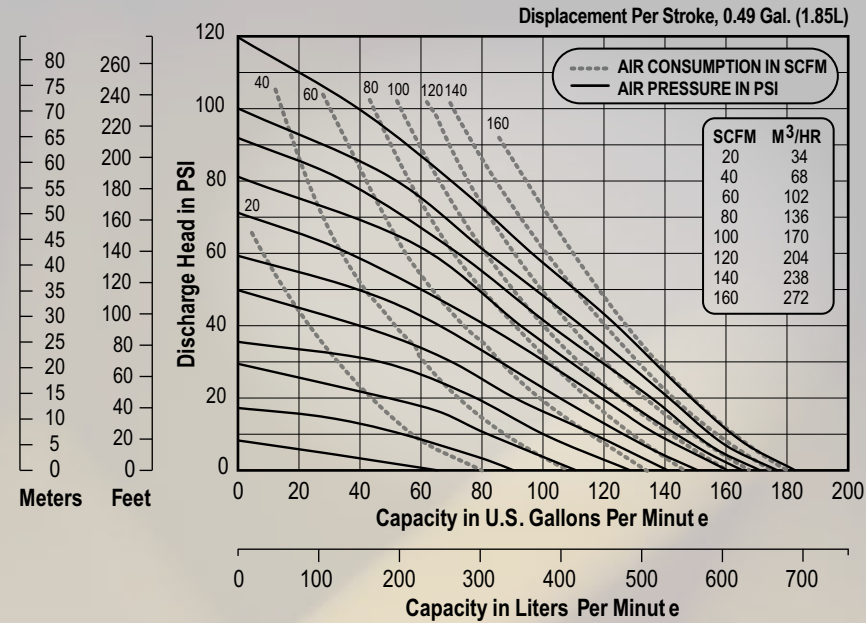

* For U2 pumps fitted with PTFE diaphragms, reduce water discharge figures by 20%.
Suction lift is reduced to 10' (3.05 m) dry and 20' (6.10 m) wet.

Dimensions

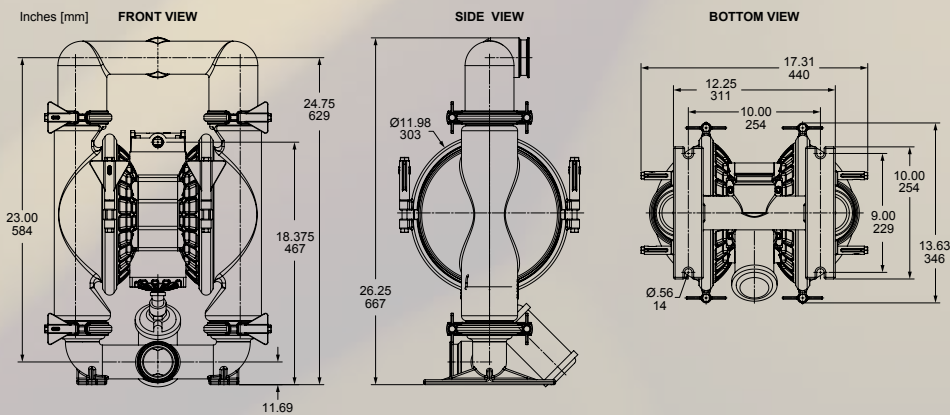

Electro-Polished wetted components
(internally and externally)



Clamp bands and wing nuts
for quick teardown and sanitizing



Tri-Clamp connections
for quick disassembly

Performance

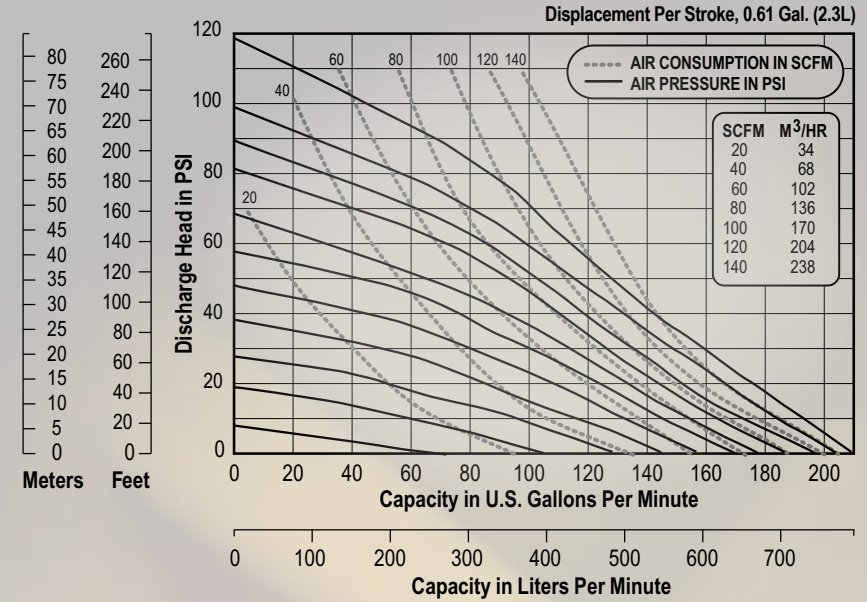

* For U2 pumps fitted with PTFE diaphragms, reduce water discharge figures by 20%.
Suction lift is reduced to 10' (3.05 m) dry and 20' (6.10 m) wet.

Dimensions

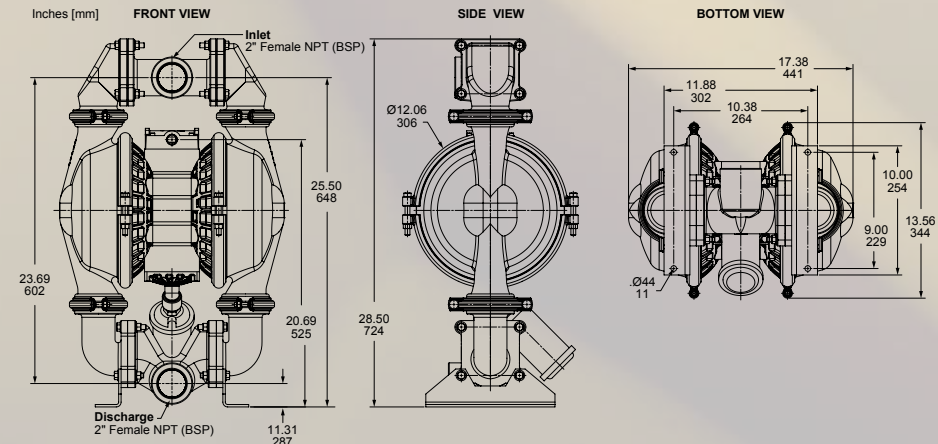

Three-piece center section
with non-metallic center and metallic air chamber options

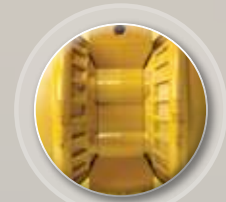

Clamp bands
for quick disassembly



Flap valves
for the pumping of solids

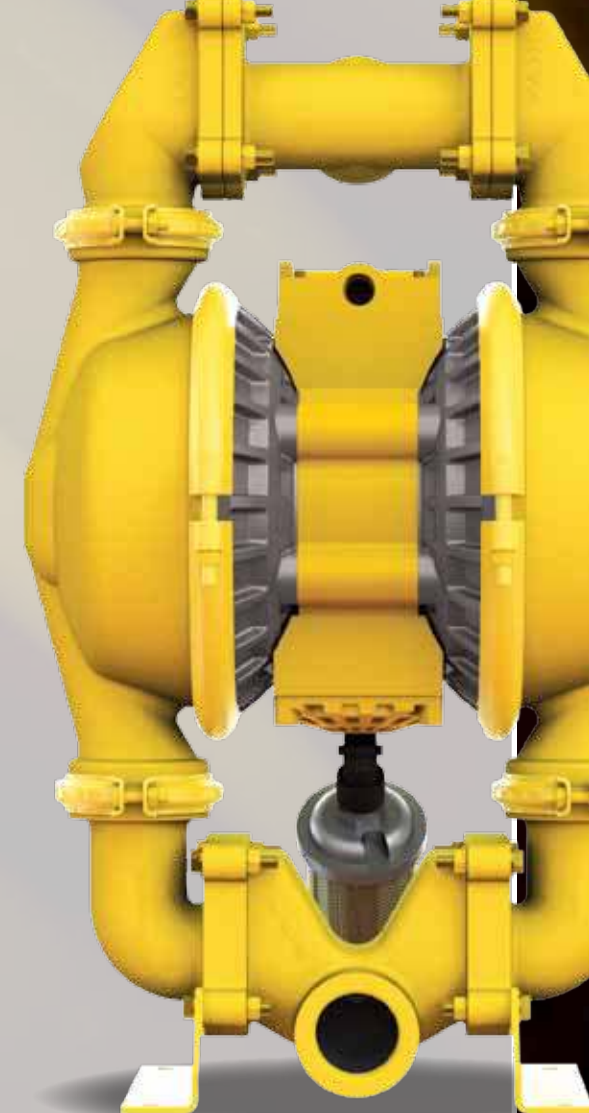

Ultra-Matic® Center Sections

Cost-effective Upgrades for Your Pumps

U2

Bolt, clamp, and revamp your existing Versa-Matic or Wilden 2" pumps center sections for improved performance and efficiency.

The simple to install Ultra-Matic center section provides a low cost upgrade solution for your existing Versa-Matic or Wilden® Original™ Series 2" pumps. Improved efficiency, flow rates, and service life at a fraction of the cost of a new pump unit. The U2 series is available in a variety of chemically resistant materials and coatings to handle even the most difficult of applications.

The unique Ultra-Matic center section is the **pinnacle of efficiency and reliability.**

3-piece center air chambers are available in a variety of materials and coatings.

Upgrade kits come complete with a new stainless steel main shaft.



Center Section Kits
For 2" Versa-Matic Bolted Pumps
Stainless Steel, Cast Iron and Hastelloy pumps

Center Section Kits
For 2" Versa-Matic Bolted Pumps
Aluminum Pumps

Center Section Kits
For 2" Versa-Matic or Wilden®
Clamped Pumps

Wilden®
Clamp-style pumps
retrofitted with U2
center sections.

Complete conversion
kits are available with
a variety of diaphragm
and plate options.



PARTS & ACCESSORIES

Versa-Matic offers the most extensive line of diaphragms in the industry, including:



Versa-Rugged VR™ Diaphragms

Our standard rubber diaphragms are reinforced with high-quality fabric and designed to reduce maintenance and repair costs. They are interchangeable with many Wilden® pump models.

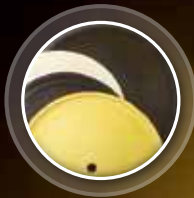

Versa-Dome® Diaphragms

An industry first, Versa-Dome's simple, smooth dome shape delivers flex across the entire face of the diaphragm to provide three times the life of standard diaphragms. They are interchangeable with most Wilden® 2" & 3" pump models.



FDA Hytrel® Thermoplastic Diaphragms

Approved for use with food and dairy mediums, FDA Hytrel diaphragms are also excellent for abrasive product transfer.



TPE-XL Thermoplastic Diaphragms

Versa-Matic's innovative thermoplastic diaphragms have much of the chemical resistance of PTFE but cost significantly less. They are extremely resistant to abrasion and are interchangeable with most Wilden® pump models.



FUSION™ Integrated-Plate Bonded PTFE Diaphragms

FUSION diaphragms enhance flow rates, displacement per cycle and suction lift. Backing ribs allow for extended life and deflection ridges eliminate radial cracking and potential leak paths.

Hytrel® is a registered trademarks of DuPont. Kynar® is a registered trademark of Penwalt Corp. Wilden® is a registered trade name of Wilden Pump and Engineering Company, a Dover Resources Company.

Elima-Matic®, Fusion™, Versa-Dome®, Versa-Matic®, Versa-Sense™, Versa-Tuff® and Versa-Rugged VR™ are registered tradenames and trademarks of IDEX Corporation. Elima-Matic U.S. Patent No. 5,326,234.

Versa-Matic's product line includes a variety of pump accessories to enhance your pump performance:



Surge Suppressors

Our surge suppressors provide virtually pulse-free discharge flow, for steadier pressure and less system vibration and noise. Self-charging and self-venting.

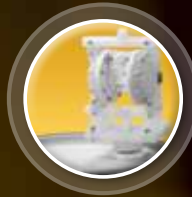

Pail and Drum Transfer Kits

These adapter kits easily connect 1/4" or 1/2" plastic pumps to a 5-gallon bucket, 120 lb. barrel or 55-gallon drum for a cleaner application.



Versa-Sense™ II Leak Detector

The Versa-Sense II protects product from contamination in the event of a diaphragm failure. The control unit can easily be wired to an audible alarm or pump shutdown device.



Flange Adapter Kits

Our new Flange Adapter Kits allow you to quickly, easily and economically convert your flange pumps to female-threaded pumps. The kits are available in three sizes for use with 1", 1-1/2" and 2" non-metallic polypropylene pumps.



Filter/Regulator/Lubricators

FRLs improve pump performance and reduce maintenance costs. Used to filter particles and water out of the compressed air coming into the pump, as well as control the air pressure. Also controls lubrication amounts to optimize pump performance.

VERSAMATIC®
GENUINE PARTS

**Repair it Once,
Repair it Right**

Learn more at
versamatic.com



VERSAMATIC®
Warren Rupp, Inc.
A Unit of IDEX Corporation
800 North Main Street
Mansfield, OH 44902 USA

Phone: 419.526.7296

Fax: 419.526.7289

www.versamatic.com



Distributed By: