



5X MORE
PRECISE
than standard
regulators



FD Series

Sanitary Back Pressure Regulators
BIOPHARMA AND OTHER SANITARY INDUSTRIES

Designed with ASME BPE in mind



“ We are committed to simplifying the valve selection process for our customers, not only with direct support from our engineers but also with valves that meet all Biopharma needs. ”
Jeff Jennings, Equilibar President

USP CLASS VI

ELECTROPOLISHED

< 20 RA FINISH¹

CREVICE FREE

CIP / SIP

Equilibar® FD Series can be cleaned in either the forward or reverse flow direction. Its design is compatible with temperatures up to 135°C experienced during steam sterilization. Reference pressure must be **disengaged** during the cleaning process to allow full flow through the valve. [Contact an Equilibar application engineer](#) to discuss your specific application requirements.

DRAINABILITY

Equilibar FD Series back pressure regulators have undergone comprehensive design and testing to have optimum drainability when oriented with the inlet down. See Fig. 1.

¹ 20 Ra finish for all wetted surfaces. [Contact Equilibar](#) for other finish requirements.

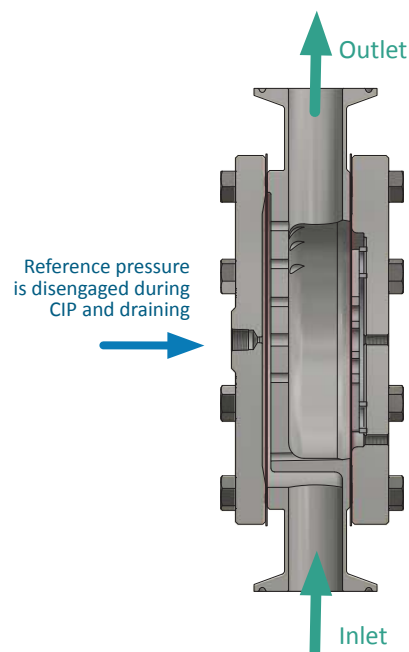

Fig. 1 FDO sanitary valve oriented with inlet down for best drainability results.

Simple Design. Brilliant Control.

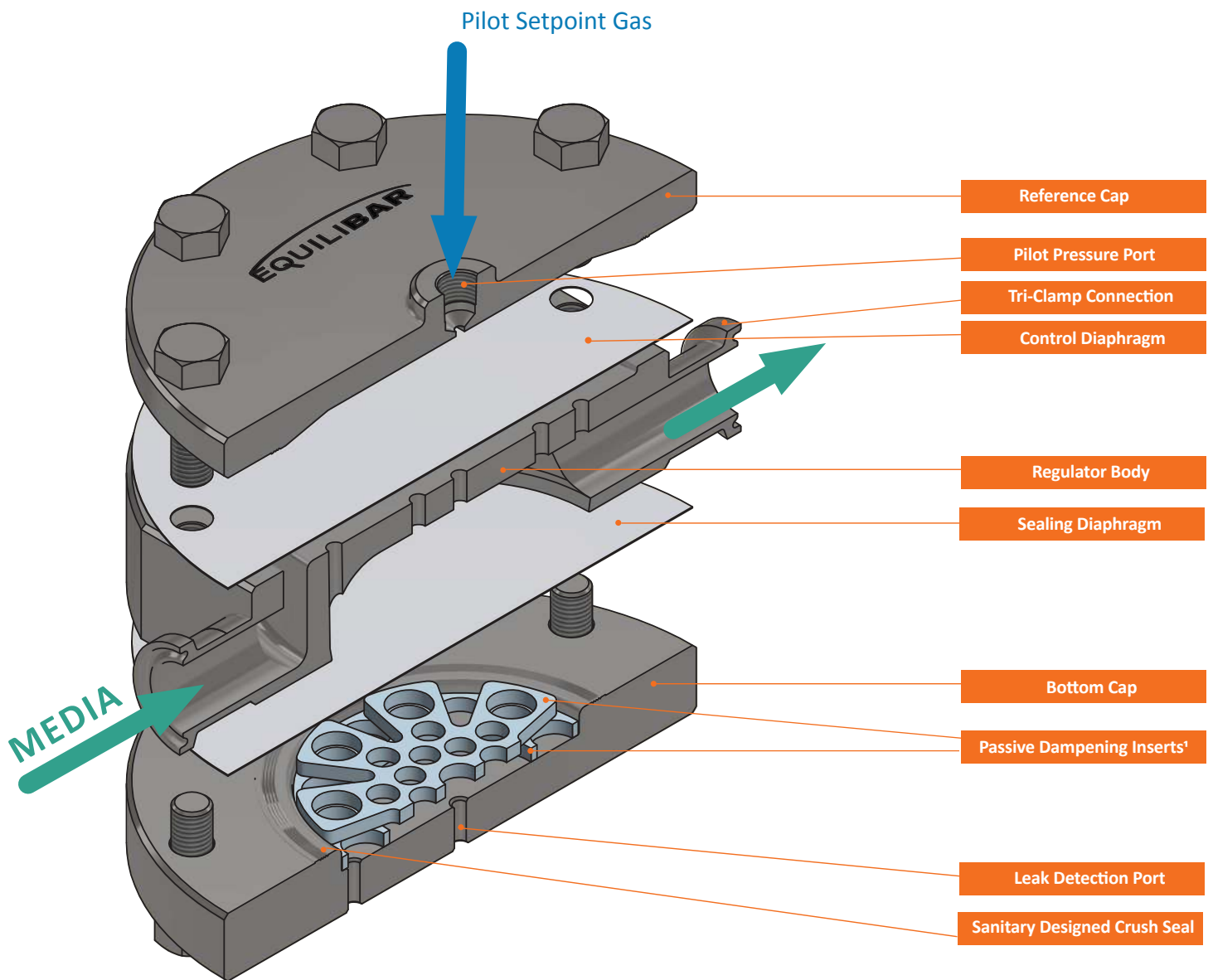

Fig. 2 Exploded view of Equilibar FD Series highlighting key features

¹Integrated passive dampening is standard in most models to help reduce possible downstream pressure fluctuations due to process equipment such as pumps.

5X MORE
PRECISE
than standard
regulators

The Equilibar Difference

Our performance.

Equilibar back pressure regulators outperform the competition, particularly in applications with low flow rates, mixed phase fluids, corrosive media, or extreme temperatures.

Our people.

Every inquiry gets focused attention from our engineering team to determine the best possible product for your needs. Every back pressure regulator is hand assembled and tested to meet our stringent quality standards.

Our priorities.

Our goal is to exceed your expectations. In an industry where delivery times frequently exceed 6 weeks, we offer many of our standard products with delivery in about a week.

Traditional back pressure regulators set the upstream pressure with a spring. These designs utilize sliding seals and other moving parts that can introduce hysteresis and other undesired effects into a process. The Equilibar back pressure regulator uses a thin, supple diaphragm as the only moving part. This allows frictionless operation without cracking pressure or hysteresis. The accuracy of the Equilibar back pressure regulator is determined by the accuracy of the pilot setpoint.



Note: Pressure gauges in photos are added for visual interest and are not included in the sales order

How It Works

Simply load the Equilibar back pressure regulator with a pilot pressure equal to the desired back pressure and the Equilibar does the rest. This pilot pressure forces the flexible diaphragm down onto a plate of orifices. A rise in inlet pressure lifts the diaphragm up to allow excess pressure to be relieved through the outlet orifices. Similarly, a loss of pressure at the inlet causes the diaphragm to be pushed closer to the orifices, restricting flow and rebuilding pressure upstream.

For **flow control**, connect an electronic pilot regulator and flow meter in an **inverse** PID loop with an Equilibar valve and it will adjust to control flow.

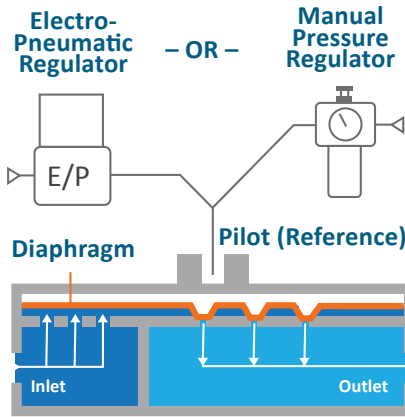

Pilot operate your Equilibar back pressure regulator with an electronic pressure regulator for automated control.

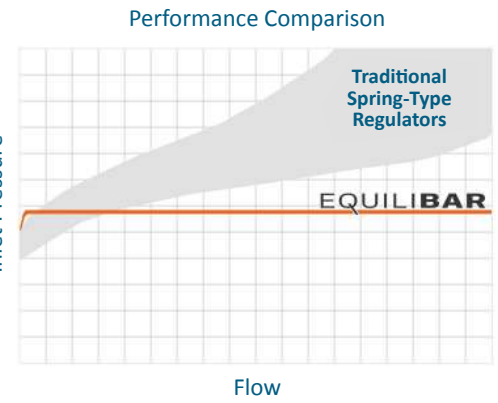

Or set the pilot pressure with a precision pressure reducing regulator for manual control.

TYPE	PRESSURE REDUCING REGULATOR	BACK PRESSURE REGULATOR
SCHEMATIC		
CONTROLS PRESSURE	Downstream	Upstream
OPENS TO	Increase downstream pressure	Decrease upstream pressure
CLOSES TO	Decrease downstream pressure	Increase upstream pressure

BACK PRESSURE REGULATORS VS PRESSURE REDUCING REGULATORS

Pressure reducing regulators reduce a higher supply pressure at the inlet down to a regulated lower pressure at the outlet (downstream). Back pressure regulators work the opposite way. They regulate the inlet (upstream) pressure by opening up only as much as necessary to hold back the desired pressure at the inlet (upstream).

Key Performance Advantages

SIMPLE COMPACT DESIGN

With only one moving part, the FD regulators are easy to disassemble for maintenance, reassemble, and return to use quickly and easily. The compact design facilitates a simple process layout.

EXCELLENT STABILITY OVER A WIDE FLOW RANGE

Traditional back pressure regulators use springs to gradually open up as the overpressure is used to compress the spring. This often results in significant inlet pressure loss with increases in process flow.

Equilbar regulators feature ultra-sensitive diaphragm-operated back pressure technology capable of controlling pressure with high precision over a wide range of flows. It fully opens in less than 1% overpressure in most applications. The stability of the Equilbar regulator is unmatched in the industry.

The graph to the right shows an example of the consistent performance of a 3/4" FD regulator with water.



FDO6 in SS316L with 3/4" Tri-Clamp fittings

FDO6 WATER PERFORMANCE

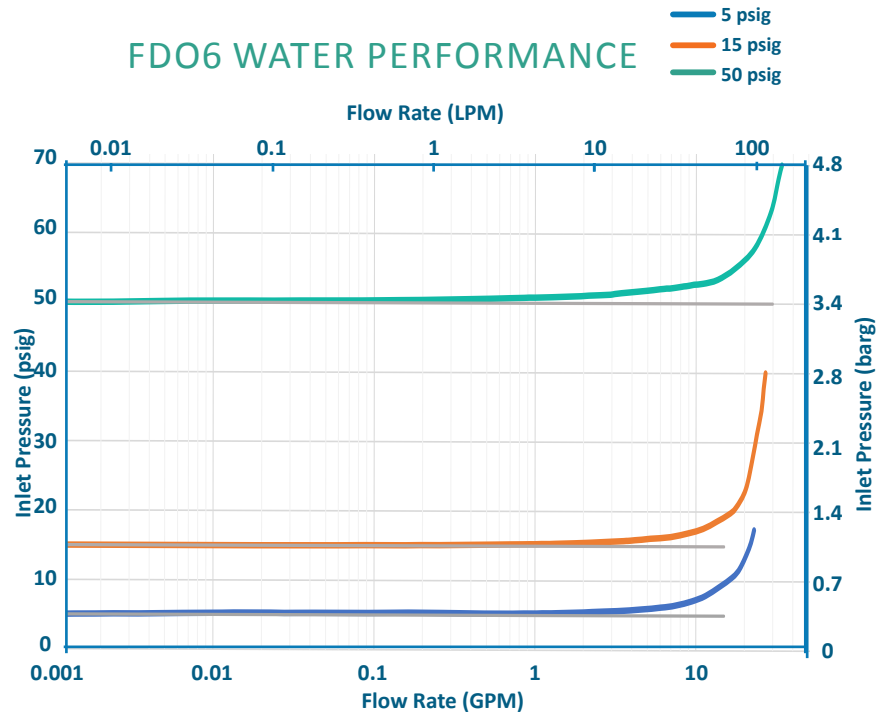

FDO6 with a QPV1 electronic pilot regulator for computer automation

SMOOTH COMPUTER AUTOMATION

Equilbar FD regulators respond instantaneously to changes in flow or setpoint to maintain the desired inlet pressure. Because of its capacity to control within milliseconds, the FD Series is a perfect match for computer automated control. Paired with an electronic pilot regulator, the FD regulator may be connected to the process control system, and it is ready for automation. It can be set up to control pressure or flow.

APPLICATION HIGHLIGHTS

Dosing Valve with High CIP Flow Capacity

WIDE FLOW RANGE

BioPharma and other sanitary processes have unique requirements for control valves due to Clean-In-Place (CIP) flow requirements. In dosing, and injection processes especially, CIP flow rates can be four times that of the process flow, making it difficult for process engineers to specify valves to meet both minimum process flow rates and maximum CIP flow rates. Typical solutions involve installing a CIP bypass line around the dosing valve to reduce excess pressure during CIP cleaning. These bypass loops create additional complexity to the process design, as shown in Fig. 1 below.

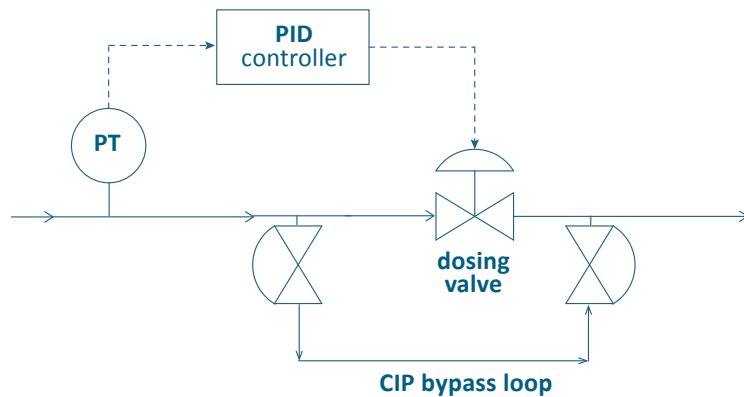

Fig. 1 Dosing process configuration with CIP bypass line

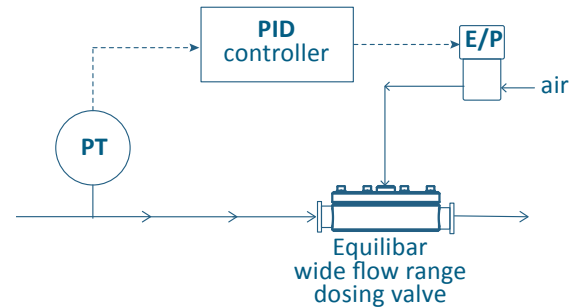

Fig. 2 Dosing process configuration with single Equilibar® wide flow range valve

The Equilibar back pressure regulator is an excellent solution for this application. Its **exceptionally broad flow range** capability allows the process engineer to specify a single valve to control low dosing and blending flow rates as well as the higher CIP flow rates. The result is a more streamlined process design, as shown in Fig. 2 above.

Gradient Chromatography

PRECISION FLOW CONTROL

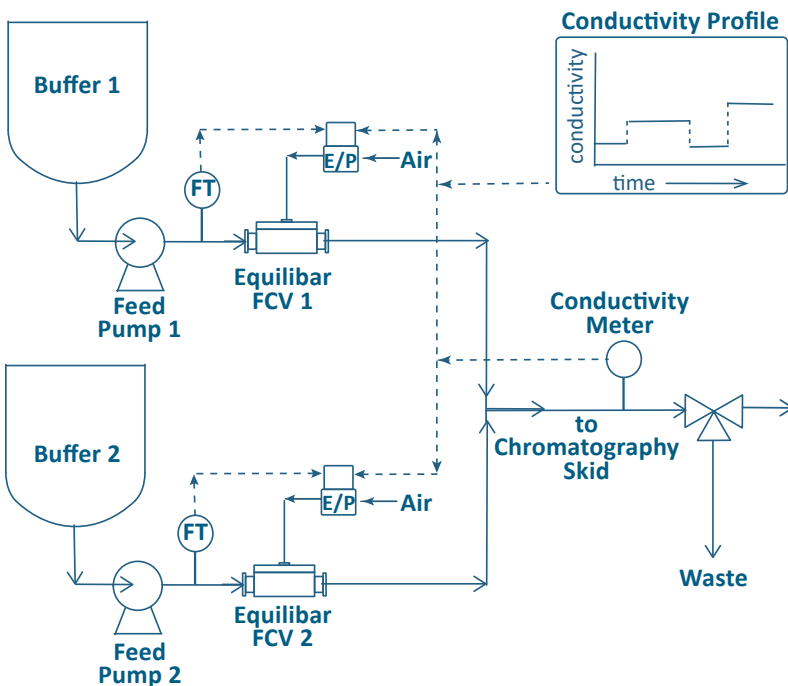

Fig. 3 Buffer blending in gradient elution skid

The Equilibar FD can act as a **flow control valve (FCV)**, when combined with a flow meter and an electronic pressure controller in an inverse control loop. Inverse because as pilot pressure setpoint increases, flow decreases.

A “gradient elution skid” or “gradient buffer skid” upstream of the chromatography skid adds buffers at varying ratios and specific timing to perform the gradient chromatography process.

Multiple buffer solutions are stored on the gradient elution skids and delivered via feed pumps to the chromatography column based on a pre-set conductivity profile specific to an elution process.

The Equilibar FD can maintain consistent flow over a wide range of flow rates, resulting in fine blending for a variety of blending processes including gradient elution, inline conditioning, and inline blending.

APPLICATION HIGHLIGHTS

Pressure Control for Biopharmaceutical Filtration DP CONTROL

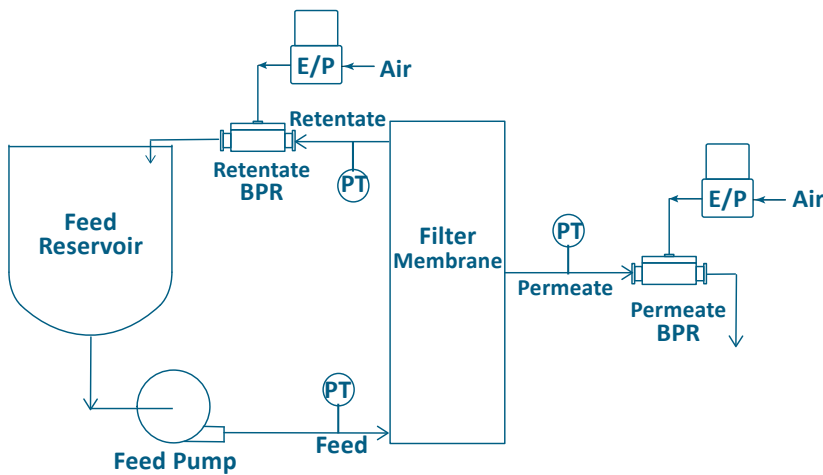

Fig. 4 Filtration pressure control using Equilibar FD BPRs

In the manufacture of biopharmaceutical products, upstream filtration may prepare media or buffer solutions, while downstream filtration typically involves purification. The **differential pressure** across a filter or separation membrane must be maintained within a narrow range. The Equilibar FD accurately controls pressure in a wide range of flow rates, making it an excellent valve choice for traditional transmembrane or cross flow filtration control.

In Figure 4, a setpoint is established on the dome of the Retentate and Permeate BPRs using an electro-pneumatic pilot regulator so the Equilibar FD valves can be computer controlled. This allows the filtration system to be controlled by differential pressure (dP) mode or by transmembrane pressure (TMP) mode.

A similar setup using flow meters can be designed for flow division control with two BPRs.

An Equilibar FD regulator is also effective for pressure control during media transfer to prevent bubbles.

High Speed Product Filling

One challenge in product filling machines is handling the rapid change in flow rate during the start-up and shut-down of a filling line. It might take several seconds during machine start-up for each of the filling positions to become active as empty containers gradually begin advancing through the machine. The opposite situation occurs at machine shut-down as the last container works its way through the positions. During these ramps up and down, the header flow rate can vary dramatically.

One solution is to install a recirculation line with a high speed back pressure regulator near the exit of the nozzle manifold. The Equilibar FD fluid control valve **responds instantaneously** (approximately 1 ms) to pressure changes at its inlet. With a high speed electronic pressure regulator (EPR) as a pilot regulator, the FD assures that the manifold pressure runs at the desired pressure at varying flow rates.

Due to its wide flow range, one Equilibar FD can control filling bottles across a wide range of bottle sizes.

INSTANTANEOUS RESPONSE TIME

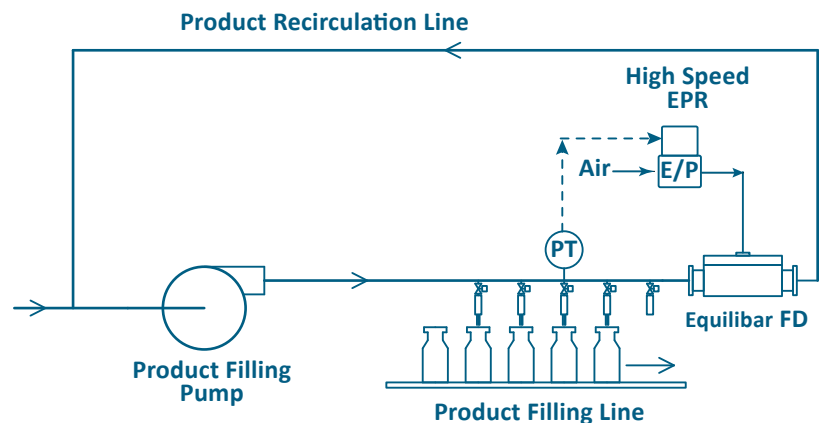



Fig. 5 Equilibar FD BPR controlling pressure in a product filling line

Pilot Control Options

Equilbar back pressure regulators are pilot controlled with a fluid setpoint pressure (also called ‘reference’ or ‘pilot’ pressure) applied to the top port. Equilbar offers these recommended pilot setpoint regulators for manual or electronic control configurations.

ELECTRONIC PILOT OPERATION

For precise electronic control, using an Equilbar EPC or QPV Series electronic pilot regulator is recommended. The pilot regulator can be mounted near the process control system for easy process integration or mounted closer to the dome of the FD regulator¹.

REGULATOR	DESCRIPTION	KEY FEATURES
EPC	 <p>Precision Electroic Pressure Controller Controls up to 150 psig (10 bar)</p> <p>0-10V or 4-20mA Analog 3.3V Serial Digital</p>	<ul style="list-style-type: none"> • Dual proportional valve control with integrated digital microcontroller • Closed loop control • 4-20mA, 0-10V or 3.3V serial command • Gauge, vacuum, and absolute pressure models • No integral bleed required • IP65 enclosure • CE models available
QPV	 <p>Precision Low Pressure Regulator Controls up to 150 psi (10 bar)</p> <p>4-20 mA or 0-10 VDC</p>	<ul style="list-style-type: none"> • Dual proportional valve control with analog electronic control circuit • Closed loop control • 4-20mA or 0-10V command • Gauge, vacuum, and absolute pressure models • Bleed orifice for static applications or dynamic applications needing max stability • IP65 enclosure • CE models available

¹ For best stability, the tubing between the outlet of the electronic regulator and the dome of the FD requires a minimum volume of 2 cubic inches / 35cc.

MANUAL PILOT OPERATION

APPLICATION	SUPPLY PRESSURE	PORTS	EQUILBAR PART NUMBER	OUTLET PRESSURE RANGE	REPEATABILITY & SENSITIVITY
MEDIUM PRESSURE					
Model 10	Max 500 psig	1/4" NPT	10212	0 - 2 psig	Less than 0.125 inH2O
			10222	0 - 10 psig	
			10202	0 - 20 psig	
			10232	0.5 - 30 psig	
			10242	1 - 60 psig	
			10262	2 - 150 psig	
			10272	3 - 200 psig	
			10282	5 - 300 psig	
			10292	5 - 400 psig	

Contact an Equilbar application engineer for assistance or visit equilbar.com for additional details.

FD Series Specifications

FOR BIOPHARMA AND OTHER SANITARY INDUSTRIES

MODEL	INLET / OUTLET PORT	REFERENCE PORT	BODY MATERIALS	DIM A	DIM A' (TUBE STUB)	DIM B	DIM C	DIM D	MAX PRESSURE	CV RANGE (PRECISION)	
				INCH (MM)					(PSIG)	MIN	MAX
FDO4	1/2" ASME Tri-Clamp	1/8" NPT	SS316L Hastelloy C & Other	3.4 (86)	N/A	1.2 (31) ¹ 1.4 (36) 1.5 (38)	2.0 (51)	0.96 (24)	150 (10 bar) standard other available on request	1E-6	1.0
FDO6	3/4" ASME Tri-Clamp			5.9 (151)	5.0 (127)	2.1 (53)	5.0 (127)	1.0 (25)		1E-5	4.0
FDO8	1" ASME Tri-Clamp			8.1 (204)	5.9 (151)	2.5 (64)	6.0 (152)	1.98 (50)		1E-5	8.0
FDO12	1.5" ASME Tri-Clamp			9.1 (230)	6.8 (173)	3.2 (81)	7.0 (178)	1.98 (50)		1E-4	12
FDO16	2" ASME Tri-Clamp			11.1 (280)	8.8 (223)	3.7 (94)	9.0 (229)	2.52 (64)		1E-4	19
FDO24	3" ASME Tri-Clamp			14.8 (375)	10.8 (274)	5.1 (129)	11.2 (286)	3.58 (91)		1E-3	36

¹DIM B for FDO4 is dependent on ID option ordered. See Option 5 on next page.

Maximum allowable working temperature (MAWT) is diaphragm dependent, typically 135°C for biopharma applications and 150°C for other applications. Please discuss your process details with an application engineer.

Follow the MAWT on the product label.

AVAILABLE DIAPHRAGMS

MATERIAL
PTFE (USP Class VI)
Jorlon™ (Enhanced PTFE USP Class VI)
EPDM (USP Class VI)
FKM Fluoroelastomer
Buna-N (Nitrile)
Glass Reinforced PTFE
Other (Consult Factory)

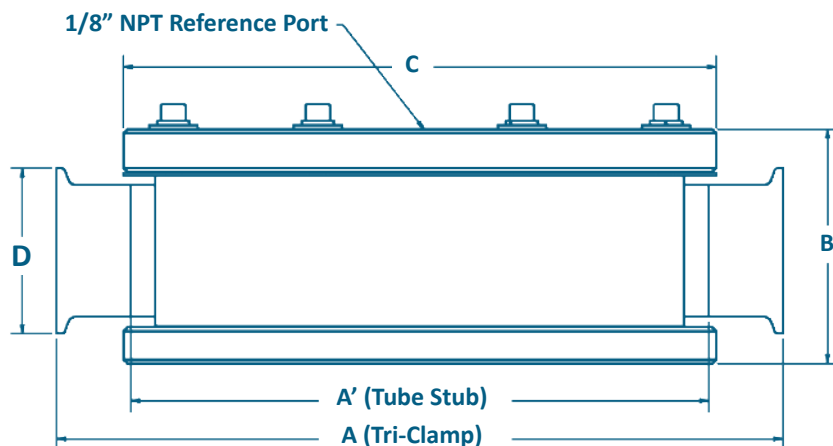

CERTIFICATIONS

Equilbar FD Series regulators have been designed and built with ASME BPE in mind for sanitary and biopharmaceutical industries. Regulators are tested prior to delivery and a Sanitary Certification Package verifying product testing is included with the order. The package includes verification of valve body materials, diaphragm materials, surface finish, electropolishing, lubricant materials and pressure and leak testing.

DESIGN OPTIONS

Equilbar FD Series valves come standard with tri-clamp fittings, but other fittings are available upon request. Surface finish options conform to ASME BPE SF4 and SF5. Custom surface finishes are available upon request. Please contact an application engineer at equilbar.com/contact to discuss your specific process requirements.

FD Series Part Number Key¹

This part number key explains our part numbering system and possible model options. All of our BPRs are custom-configured by our engineers based on the customer's specific application's parameters (process fluid, pressures, flow rates, temperature, etc.). Our engineers will request process operating parameters in order to build and quote a full part number for a suitable regulator. This chart is a reference to help understand the chosen part number.

EXAMPLE																	
FDO	6	S	H	N	4	-	N	S	C	P	150	T	135	J	10	P	S
1	2	3	4	5	6		7	8	9	10		11		12	13	14	15

1 MODEL

FDO FD series, in line

FDT FD series, angled (Consult Factory)

2 PORT SIZE

4 1/2"

6 3/4"

8 1"

12 1.5"

16 2"

24 3"

3 BODY MATERIAL

S Stainless Steel 316/316L

H Hastelloy C276

I Hastelloy C22

4 PORT TYPES²

H ASME BPE Tri-Clamp

T Tube Stub

5 OPTIONS

D 6 mm ID (FDO4 Only)

E 10 mm ID (FDO4 Only)

H 0.370 in ID (FDO4 R6 only)

I 0.305 in ID (FDO4 R6 only)

K 0.180 in ID (FDO4 R6 only)

L Low flow, 6 mm ID (FDO4 Only)

N None

U Flow Through Option (FDT only)

6 MOD # (REVISION)

(Factory Selected)

7 REFERENCE PORT THREADS (NON-WETTED)

N 1/8" NPT

D 1/8" BSPP

8 CAP MATERIAL

(Use same ID as Body Material)

S Stainless Steel 316/316L

9 BOLTS

(Factory Selected)

10 PRESSURE RATING

This is the maximum pressure you would like your unit to be configured to accept. Must be equal to or less than the maximum body pressure (150 psig / 10 bar(g))

11 TEMPERATURE RATING³

135 BioPharma applications (typical)

T custom/application-specific

12 DIAPHRAGM MATERIAL

G PTFE (Glass Reinforced)

J Jorlon™ (Enhanced PTFE, USP Class VI)

F PTFE (Virgin, USP Class VI)

B Buna-N (Nitrile)

V FKM Fluoroelastomer

M EPDM

U EPDM, USP Class VI

13 DIAPHRAGM THICKNESS

(Factory Selected)

14 PULSATION DAMPENING

P Passive dampening (standard)

15 OTHER OPTIONS

S Sanitary Certification – intended for use in biopharmaceutical industry

¹ Items in blue are typically in stock for fast shipment

² contact Equilibar for custom port types

³ Contact an application engineer if you have questions about temperature rating

PATENTS

equilibar.com/support/patents/

About Equibar

Equibar provides innovative and robust pressure and flow control technology for researchers and engineers worldwide. We are proud to design, manufacture, and test our patented back pressure regulators in our factory overlooking the Blue Ridge Mountains near Asheville, NC, and we are equally proud to work with clients around the world each and every day.

APPLICATION ENGINEERING— WHAT SETS US APART

Unlike mass-market regulator distributors, we focus on working with you, the scientist or engineer with a complex pressure control scenario.

Our application engineers work collaboratively with clients to identify the optimal model, trim, and diaphragm for each application's unique challenges. No matter where you are on the globe, you can stay in close contact with your engineer by email, telephone, videoconferencing, or fax.

After installation, your application engineer will support you with start-up information and fine-tuning as needed.

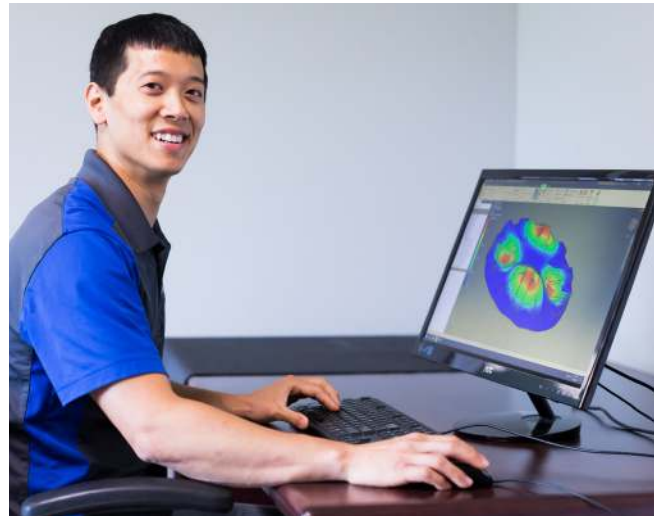

Our engineers offer custom designed solutions for the most difficult pressure control challenges. Feel free to contact us to discuss your situation.



Equibar, LLC
320 Rutledge Rd.
Fletcher, North Carolina 28732
United States
Tel: +1-828-650-6590
Fax: +1-801-504-4439
Monday - Friday
8:00 AM - 5:00 PM EST
12:00 - 21:00 GMT
inquiry@equibar.com

RELATED PRODUCT

The Equibar back pressure control valve is now available in a Single Use format to accommodate the rapidly expanding requirements of BioPharma industry.



Made in the
USA

Equibar's quality system is
ISO 9001:2015 certified.